

SchuF Fetterolf Valve Portfolio

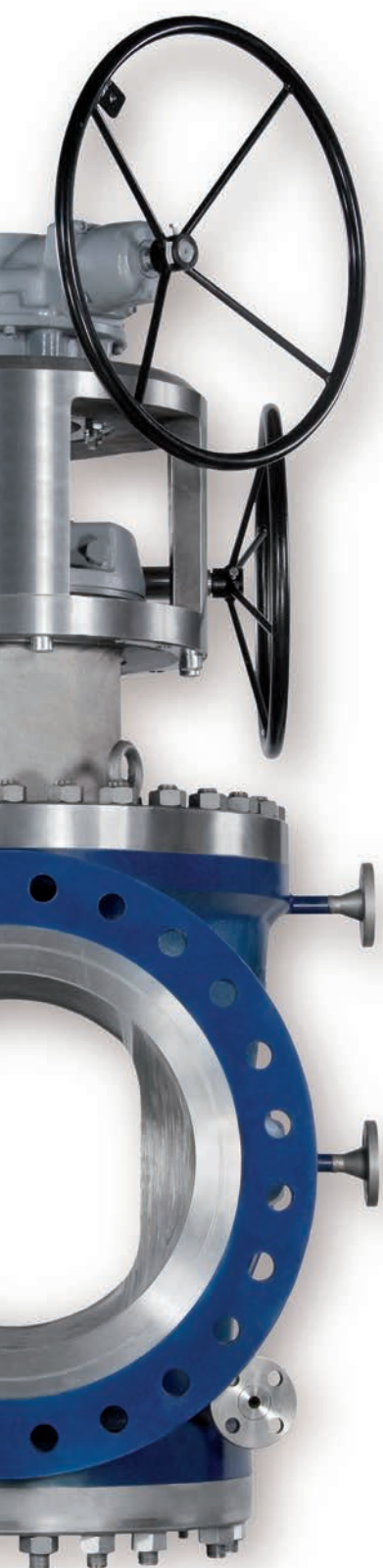

Table of Contents



	Page
SchuF Fetterolf Company Profile	3
Drain and Sampling Valves	4
Disc Bottom Outlet Valves	4
Ram Bottom Outlet Valves	5
Flush Bottom Outlet Valve Examples	6
Sampling Valves	7
Isolation Valves	8
Lift Plug Valve	8
TruEPlug Valve	9
Y-Globe Valves	10
High Pressure Angle Valve	11
Blowdown Valves	11
Control Valves	12
Angle Control Valves	12
In-line Control Valves	13
Control Valve Overview	14
Flashing Solutions	17
Cavitation Control	18
Automatic Recirculation Valve	19
Switching Valves	20
Diverter Valves	20
SwitchPlug Valve	22
ManiFlow Selector Valve	23
Spray Rinse & Injection Valves	24
Spray Rinse Valve	24
Steam Injection Valves	25
Safety Related Valves	26
Line Blind Valves	26
Changeover Valves	27
Tank Emergency Shut-Off Valves (TESO)	28
Product Portfolio Overview	29

Company Profile

“Every SchuF valve is an innovation in itself”

Wolfgang Frank
Chairman, SchuF Fetterolf Group

For over 100 years SchuF valves have stood for innovation and quality at the highest level.

Together with our customers, we invent, design and manufacture valves customised to exact tolerances, processes or special operating conditions. SchuF Fetterolf valves can be found in standard and in many severe service applications in the Chemical, Polymer, Pharma, Oil, Gas, Offshore and Refining industries.

... Innovation

The invention of the Lift Plug valve in 1911 and piston & disc bottom outlet valves in the nineteen twenties by the founder of SchuF – Josef Frank – were the first of a long line of valve inventions and innovative designs. Continuing research and development in materials (used in valve bodies and trim), design as well as complex processes enable SchuF today to offer valve solutions for applications with high pressure, high temperature and difficult media; or a combination of all three.

The integration of Fetterolf Corporation in 2004 further broadened the Group’s product portfolio, innovation and geographical reach. Today the SchuF Fetterolf product line includes control, isolation, sampling, switching and safety related valves.

... Quality

The exceptional quality and longevity of SchuF Fetterolf valves is a result of the precise attention to process detail, creative design, and the use of the appropriate high quality materials. In addition to its own high internal company standards, SchuF is ISO 9001, GOST and PED certified and can manufacture according to ASME, DIN, NACE, API, Fire Safe, GMP, JIS or any other internationally recognised standard.

... Worldwide presence

SchuF Fetterolf is represented in over 65 countries worldwide and has design and production facilities in Germany, Ireland, India, Italy, the United States and the United Kingdom.



Bottom Outlet and Drain Valves

SchuF invented the first industrial class bottom outlet valve 100 years ago. Today SchuF Fetterolf offers tank bottom valves with a disc or piston design in almost any material, pressure class or size and with many options.

Disc Bottom Outlet Valves (DBOV) – Model 18 / 19 / 24 / 25

Application

Disc bottom outlet valves are commonly used in Pharmaceutical and Fine Chemical processes to drain or feed non-viscous media from vessels or reactors. Reactor considerations such as the position of internal mixing equipment and the nature of the media determine the need to use a disc lowering or disc rising valve variant.

An additional benefit of the latter is that the formation of crust is automatically removed when the disc is moved to the open position.

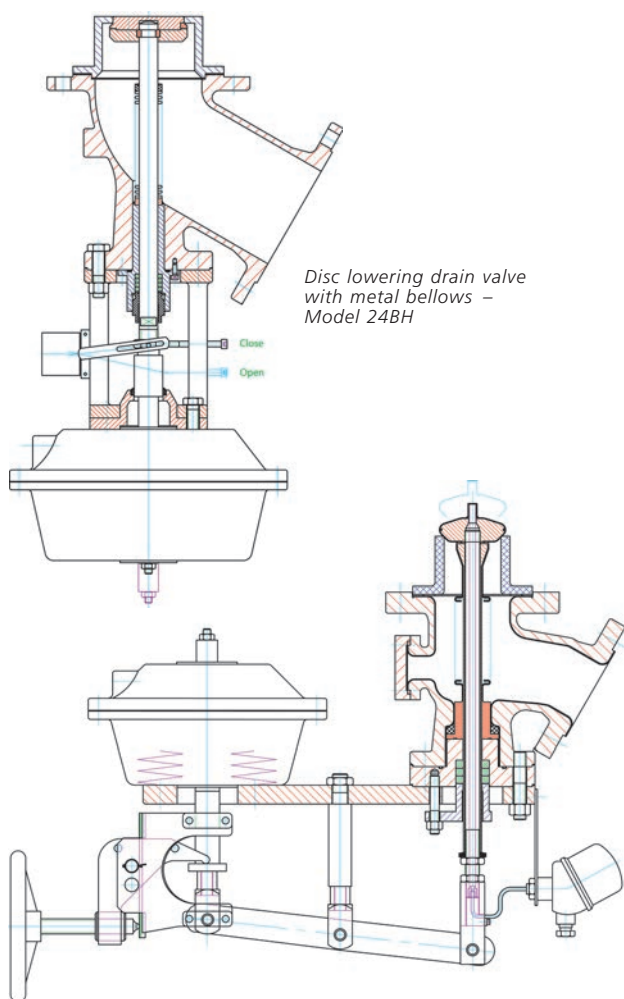

Disc rising drain valve with side actuation – Model 25BF

Key Advantages for Disc and

■ Compact Valve Build

A short stroke disc valve is ideal where space is limited or weight is a concern. Smaller, lighter and faster actuators can be used.

■ Dead Space Free

SchuF drain valves are designed to ensure that the vessel and the valve itself drain completely. There are no spaces for matter to accumulate.

■ Crust Breaking

For media containing crystals or crust forming substances, certain ram and disc valves offer the ability to clear any blockage and ensure problem free flow.

■ Zero Emissions to Atmosphere

Disc valves can be fitted with a metal or PTFE extruded bellows or a PTFE Diaphragm. Leakage of toxic or flammable substances are eliminated.

All Disc and Ram valves are available in sizes from 1" (DN25) standard. The outlet angle can be 45°, 60° or 90°. Customizations are available on request.



Options

- Fire Safe design
- CIP (Clean in Place)
- Temperature sensing
- Wide choice of material
- GMP designs
- PTFE or glass lining
- Heating jacket
- Disc grinding
- Flushing connections
- Leak detection

Flush bottom outlet valves can also be used for feeding, injection or sampling applications. Special designs are available for critical processes or media such as slurries. SchuF valves are customised to meet your exact equipment or process needs.

Piston Bottom Outlet Valves

■ **Fast Draining**

Full bore unimpeded flow piston valves are ideal to quickly drain reactors, tanks or pipelines.

■ **Diverse Sealing Options**

Metal to metal or soft seal in the valve body, vessel or with an extend-ed sleeve ensure the right sealing characteristics for different process requirements. Please see page 6.

■ **Super Closure**

Super Closure is a self adjusting mechanism, that ensures a constant bubble tight seal to atmosphere.

■ **Customised Design**

Every SchuF valve can be customised to match the exact specification of the vessel, reactor or tank. Material and instrumentation can also be customised for specific plant requirement.

■ **Replaceable Valve Seat**

The ability to easily change the customised valve seat reduces downtime and saves money.



Ram drain valve – Model 26FR

Ram Bottom Outlet Valves (RBOV) – Model 26 / 28

Application

Piston bottom outlet valves are used to quickly drain or feed vessels or reactors. They are normally full bore. For these reasons piston BOVs are favoured for processes with viscous media. They clean the valve body with each piston stroke and optionally can clear crust or scale around the vessel outlet.

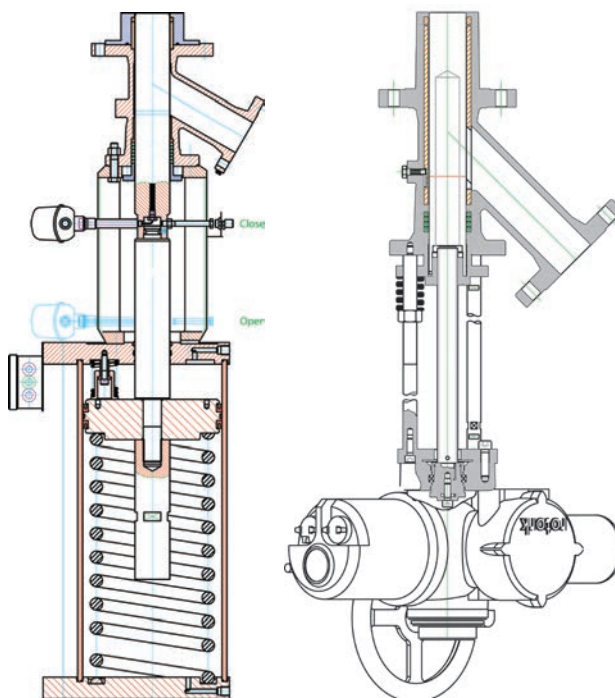

Ram drain valve – Model 28KR

Rod Seal drain valve – Model 26FR

to 24" (DN600) and up to ASME 2500# pressure class as standard design, larger nominal bore and higher pressure classes

- High corrosion resistant coatings
- Full automatic control
- Internal/External polishing
- Hard facings
- Contoured pistons
- Position and safety sensors
- Manual, pneumatic, hydraulic or electric actuation

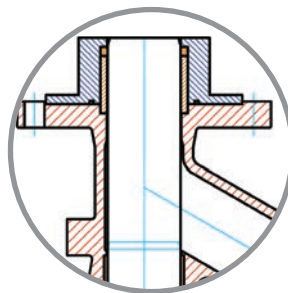

Detail: Soft Seal in the vessel

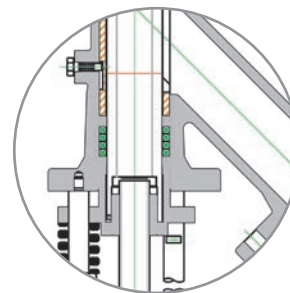

Detail: 26FR – Super Closure

Bottom Outlet and Drain Valves

Flush Bottom Outlet Valve Examples

Hydraulic Actuated Disc Valve – Model 25BH

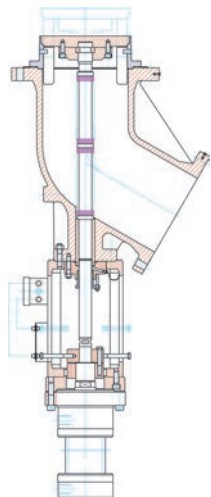

Features & Benefits:

- Powerful space saving hydraulic actuation
- Rising disc with automatic crust breaking
- Metal bellow seal for zero emissions
- Ideal for higher pressure or temperature applications

Short Stroke Ram Valve – Model 28KS

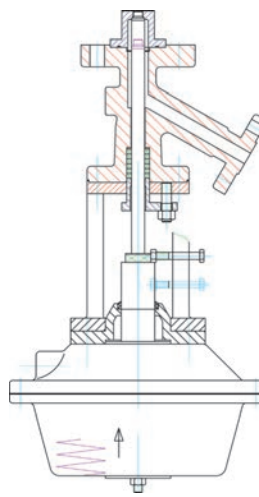

Features & Benefits:

- Short stroke valve with pneumatic actuation
- Ideal where space is limited but fast draining and injection is required

Sealing Method Options

Custom Fit Seat Sealing Options

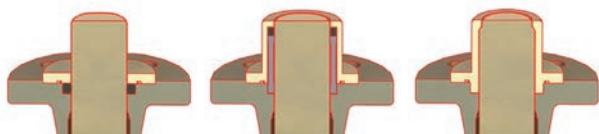

Model 28KV
Radial soft seal in the valve body

Model 28KR
Radial soft seal in the vessel

Model 28KS
Metal seal in the vessel

Integrated Seat Sealing Options

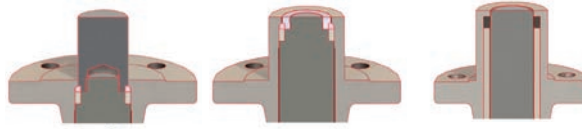

Model 28FX
Extended plunger

Model 28FS
Extended body

Model 26FR
Extended body with a radial seal

MultiProbe™ Valve – Model 25BX



Features & Benefits:

- Infrared (IR) reaction monitoring for Process Analytical Technology (PAT) applications
- Integral IR and temperature sensor in one stem and disc
- Equipped with a unique and patented sealing system

Disc Lowering Valve with Diaphragm – Model 24BM

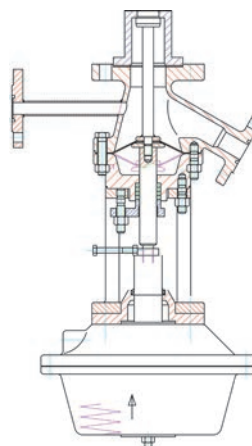

Features & Benefits:

- Zero leakage to atmosphere with diaphragm inside the valve body
- Flushing connection for in service cleaning
- Typically used in Pharmaceutical applications

A full brochure is available at: www.schuf.com/pdf

Sampling Valves

Sampling Valves

Many chemical and pharmaceutical processes need to be regularly tested during processing to ensure consistent product quality. SchuF Fetterolf sampling valves enable trouble free and safe content sampling of pipelines, reactors, tanks and storage vessels without product loss or cross contamination.

Product Range

Screw-in Sampling Valves – Model 32

- Screw-in or flanged to pipelines, reactors or vessels
- Size up to 1½" and ASME 600#
- Available with different flange and seat options
- Materials: carbon steel, stainless steel and most alloys
- Diverse sealing options include:
 - Metal Seated Ram (32PG)
 - Metal Seated Disc (32PT)
 - Ram PTFE Seal Rings (32FR)
 - Metal Seated Ram with PTFE Seal Ring (32FG)



Core Pipe Assembly – Model 30

- Sampling valve with an integral core pipe assembly & heating jacket
- Sampling under high temperature and pressure up to ASME 2500#
- Vertical or horizontal installation
- Contoured ram options
- Customised assemblies to match your exact sampling requirements



A full brochure is available at: www.schuf.com/pdf

Wafer Sampling Valves – Model 31

- Sampling valve with integral flange insert
- Flange insert is installed into the product line
- Insert size up to 12" and ASME 600#
- Available with any Model 32 sealing options



Key Features:

- Robust construction for longer valve life
- Dead space free, non clogging design
- Class V or VI shut-off
- Standard designs are stocked, customised design on demand
- Heating jacket and optional outlet legs
- Fire safe design according to ISO 10497

Customised sampling systems for many applications such as:

- Fixed volume sampling under high pressure and temperature
- Sampling with zero leakage to the atmosphere
- Wet or dry powder sampling
- Visual checks through sight glasses



Isolation Valves

Lift Plug Valve – Model 12

SchuF invented the Lift Plug Valve in 1911. It is the original double block and bleed (DB&B) isolation valve.

Applications

Lift plug valves are primarily used to isolate or switch media flow, but are particularly suitable for severe applications at high temperatures or with highly abrasive or clogging media. Some process and media examples include:

- Delayed coking
- Acetic acid
- Urea
- Cement
- Polymers
- Liquid sulphurs
- Chlorine gas
- Power industry

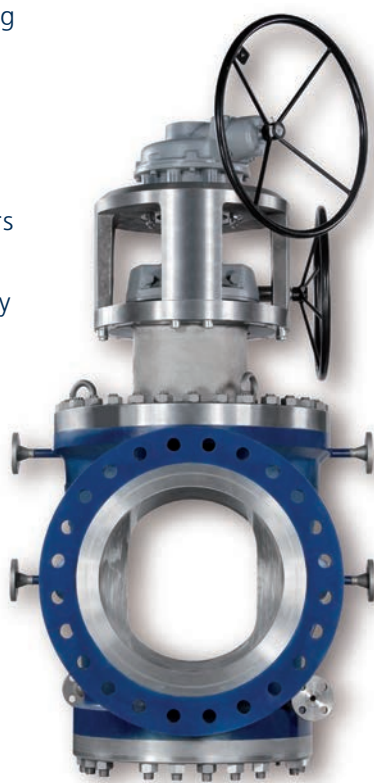

20" ASME 300# IsoPlug™

Design

The lift plug valve consists of a few key parts – body, plug and an actuating device. There are no sealing rings, bellows or gaskets that can break, clog or fail.

Operation

During operation the valve plug is lifted and turned from open to close via a lift-turn-reseat mechanism that can be actuated manually or using an electric, pneumatic or hydraulic actuator. In the open or closed position, there is no gap between the plug and the valve body where the fluid and its contents can settle, contaminate or score the valve.

Key Features:

- Size: 1" (DN25) to 36" (DN900)
- Pressure Class: all to ASME 2500#
- Full bore plug design
- Protected valve seat (PVS)
- Integral double block and bleed
- Dual motor actuation
- 3 line Sediment Defence System (SDS)
- Integral flushing

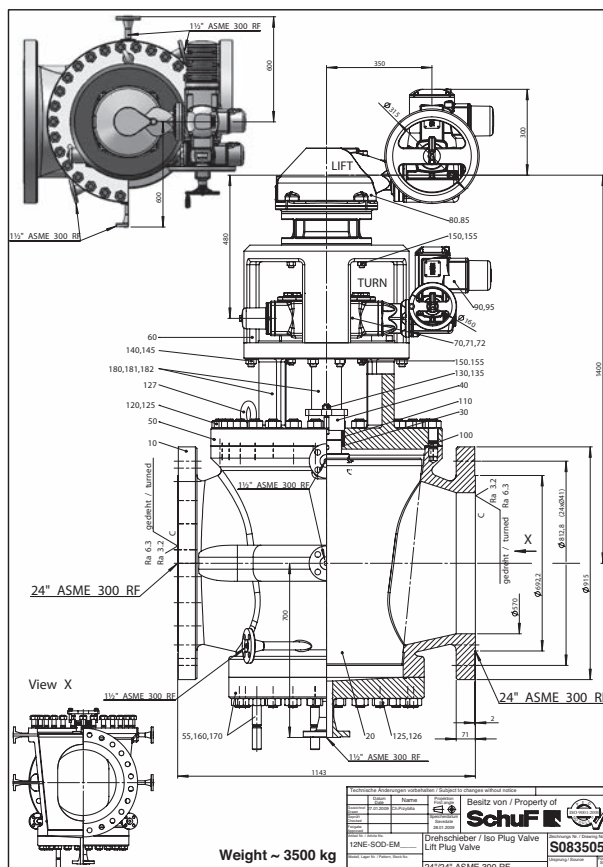

Benefits

- Ideal for high temperature & dirty media
- Smooth turn non-stick plug
- Dead space free
- Sediment free – 3 line defence system
- Easy to maintain

TruEPlug Valve – Model 11

The TruEPlug is a special rotary plug valve that achieves true Double Block and Bleed (DB&B) service in one enclosed valve body. It belongs to the SchuF family of lift plug isolation valves invented in 1911.

Applications

The TruEPlug is suitable for isolation of mostly clean media at moderate temperatures (to 256°C) where seal tight closure is essential.

Typical applications include:

- Tank storage isolation
- Meter stations
- Loading/Unloading terminals
- Fire suppression system isolation
- Branch line isolation

Operation

The TruEPlug has a simple yet efficient design with few pieces. The key parts include the body, bonnet, plug, seals and actuator. The plug has a special moving insert or shield that is fixed to the central plug and has an inlaid soft sealing ring.



As the plug lifts and rotates from the open to the closed position, clearance is maintained between the plug shield and the valve body, allowing free movement and avoiding scoring.

As the plug enters its closing position it is lowered forcing the plug shield against the body and thereby initiating a soft seal. In the closed position the plug shields are effectively expanded (the reason why the valve is sometimes referred to as an Expanding Plug valve).



TruEPlug Seal Shield

The soft seal is further compressed until a metal to metal seal is achieved.

This double mechanical sealing mechanism gives the TruEPlug one of the most reliable leak tight seals available.

Key Features:

- 1" to 42" and up to ASME 900#
- Replaces traditional two valve and spool piece DB&B arrangement
- Reduced bore or full bore piggable
- Positive shut-off double seal
- Abrasion-free plug movement
- Bleed function proves zero leakage
- Metal to metal seal in the open position
- Manual, electric or pneumatic actuation
- Fire Safe option

Benefits

- Quick and easy operation
- Cost effective DB&B
- Zero leakage
- Easy maintenance

Isolation Valves

Y & P Pattern Globe Valves – Model 50

SchuF Fetterolf provides globe type isolation valves in a Y, P, and Straightway pattern. They offer class V or VI shut off and are ideal to replace leaking or clogging ball valves or where bubble tight shut-off is essential.

Application

Globe valves are widely used to isolate process lines where the pressure drop across the valve needs to be minimised without sacrificing sealing performance. All SchuF Fetterolf globe valves meet or exceed these criteria.

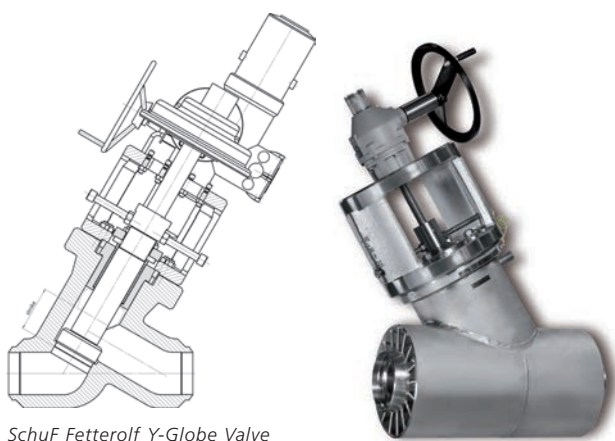

SchuF Fetterolf Y-Globe Valve

Key Features – Y & P Globe Valves:

- Size: 1" (DN25) to 24" (DN600)
- Pressure class: up to ASME 4500#
- Low pressure drop (ΔP)
- Zero leakage to atmosphere
- Dead space free options
- Positive shut-off
- Roddable and piggable designs

"Straightway" Y-Globe Valve

The straightway valve was designed to deliver Class V & VI, as well as API standards for zero leakage. It has the patented Ram-Seal mechanism which utilises a dual metal seal plus a PTFE seal ring encircling a solid plunger.

It distinguishes itself as a fully roddable valve with the lowest ΔP values available.

A full brochure is available at: www.schuf.com/pdf

It is commonly installed in refineries, petrochemical and nuclear power plants (e.g. in radioactive waste applications).

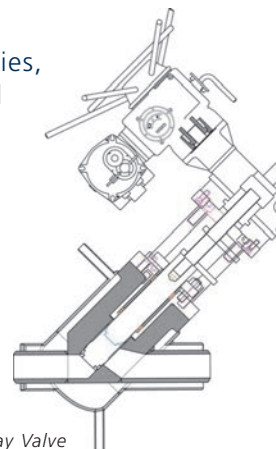

SchuF Fetterolf Straightway Valve

"P" Globe Valve

The new P-Globe straightway valve has been designed for applications that require intermittent pigging. It incorporates the optimal pressure drop and sealing characteristics of the globe valve and a full bore unimpeded flow path. It is also bi-directionally piggable.

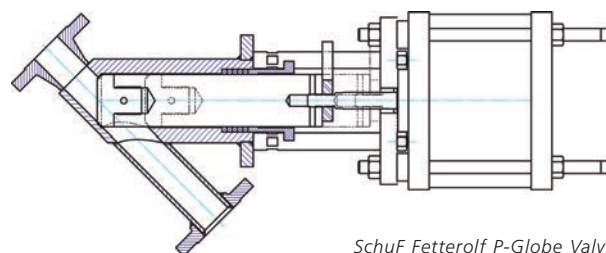

SchuF Fetterolf P-Globe Valve

Options

In addition the Y-Globe, Straightway and P-Globe valves are available with many options – disc grinding in slurry or crystal forming applications, heating jackets to ensure the optimal temperature medium flow, bellows for a positive seal to atmosphere, vacuum yokes and many flow control features.

Benefits

- No leakage; clog free
- Optimal flow characteristics
- Man safe isolation
- Full bore, unimpeded flow path

High Pressure Angle Valve – Model 71

High pressure angle valves are typically used to isolate process flow where the medium is under high pressure (200 bar +).

In these circumstances media properties partially change dramatically and valves need to withstand corrosion and erosion due to high pressure, cavitation, flashing, crystal formation and vibrations to name a few.

Application

The SchuF high pressure (HP) angle valve is used in several industries including polymer, urea/carbamate, power generation, fertilizer, and oil & gas.



Key Features:

- Size: 1" (DN25) to 20" (DN500)
- Up to ASME 2500# and above
- Single piece polished plug & spindle
- One piece body and heavy yoke
- Exchangeable front and back seats
- Back seating – enhances seal to atmosphere and protects the spindle
- Class V or VI seal to process
- Top or side entry for easier maintenance

SchuF applies its flashing and cavitation prevention and avoidance expertise to ensure lower maintenance and extended valve life. This includes a combination of valve design (angle design or customised outlet), simulation, material choice (e.g. Ferralium 255 for trim parts), and 100 years of valve experience in many extreme processes.

Blowdown Valves – Model 50 / 71

Blowdown valves are used to remove impurities from boilers or their associated pipelines in order to maintain boiler integrity and efficiency.

Application

Intermittent blowdown allows for the removal of alkaline earths, phosphates or polyacrylates that can form a sludge layer at the bottom of the boiler. If not removed, a dangerous insulating scale layer can form on the heating surfaces, and reduce heat transfer. Regular, intermittent blow down for a few seconds removes this safety risk. SchuF provides both intermittent and continuous blowdown valves in both angle and Y-globe valve designs.

Key Features:

- DN15 to DN50 and up to ASME 1500#
- Single piece plug and spindle
- Both disc and seat are hard faced with Stellite for erosion resistance
- Linear or multistage control trim option for high pressure let down
- Manual or pneumatic actuation
- Spring to close for rapid blow down
- Back seating option
- Lever option for rapid operation

Continuous blowdown is the most effective blow down operation. Dissolved solids are removed in a continuous process so that the minimum quantity of water is discharged from the boiler.



Benefits

- Rugged compact design
- Improved blowdown effectiveness
- Insensitive to water-hammer effects
- Longer life and availability

Control Valves

Control valves work to keep a process variable such as flow or pressure within a predefined operating range. They are often the last piece of equipment in a process loop that can compensate a load disturbance and are therefore considered critical valves.

Custom Applications

SchuF's experienced design engineers provide you with unique valve designs to meet both usual and unusual process demands. Special application designs, in service worldwide and showing continuous satisfactory performance, include:

- Discharge and feed flow control valve in **PET, PVC, PP & PE** reactors
- Level, pressure & steam injection control valves in **PTA** processes
- Level control of flashing fluid in **coal liquefaction** or **heavy oil upgrading**
- Feed and level control for **gasification** according to the Siemens, Lurgi, GE and Shell process licences
- Flow control of powder in **fine chemical & pharmaceutical** processes
- High precision multi-port flow control of highly viscous, non linear, non-Newtonian **polymer** fluids
- Discharge flow control valve for **urea** reactors where urea grade stainless steel is mandatory
- Fully jacketed short body wafer control valves, for **Nylon** and **PC** production
- Mineral processing applications such as high pressure acid leaching (**HPAL**)
- Sour water and Amine letdown in several **refinery** processes
- Resurge and flare control for **gas**

Angle Control Valves – Model 74

The SchuF Model 74 Angle Control or Choke Valve is designed for critical or severe applications involving level control and pressure let-down in High Pressure Acid Leach (HPAL), Hydrocracking, Coal Liquefaction, PTA and other demanding processes.

Available in sizes from 1 inch to 36 inches and up to ASME 2500# as standard, SchuF can address almost any size or pressure class. Materials of construction include cast or forged Carbon or Stainless Steel, Hastelloy, Inconel and Titanium bodies with ceramic or tungsten carbide trim components for handling flashing slurries of 20% solid content and above.

The SchuF Angle Control Valve is often custom made to process requirements in order to optimise field performance. Valve bodies are simulated to extend service life, by preventing impingement of particles on internal surfaces. Stagnant areas are minimized to prevent build up of slurry or scale.



SchuF Control valves optimise Cv to port performance.

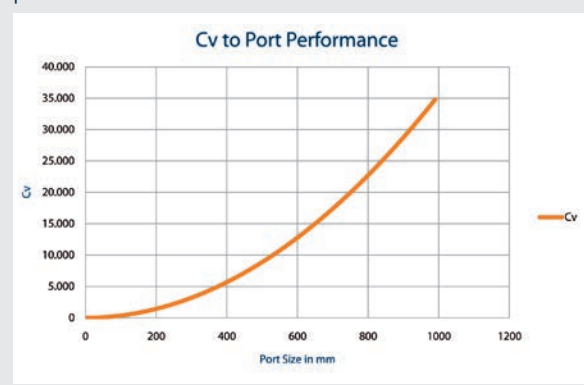

Key Angle Control Valve Features:

- **Accelerating Flow Path:**
Acceleration of abrasive process media is maintained continuously through a sweeping, non-expanding angle body to prevent flashing until the fluid, gas or slurry enters the protected outlet area. There is no stagnant space where process slurry can form eddies or undesired turbulence.
- **Cv Sizing for 3 Phase Flow:**
SchuF's proprietary Cv sizing model is particularly well adapted to three phase flow media.
- **Large Stem Diameter:**
Stem diameters are individually sized to eliminate deflection and the possibility of damage to critical trim components.
- **Replaceable Valve Seat:**
The ability to change the customised valve seat reduces downtime and saves money.
- **Unique Flow Characteristics:**
Linear and equal percent control characteristics are available as standard. Customers can opt for SchuF's patented X³ bell curve for better control at known operating levels.
- **Anti-Rotation Device:**
The yoke includes a device to stop the valve stem from turning when the valve plug is subjected to high velocity lateral fluid flow.
- **Cast Yoke:**
Rugged yoke bracket in cast stainless or carbon steel is used to prevent structural deformation when the valve is mounted in non-vertical positions.
- **Cavitation & Flashing Solutions:**
Please see the flashing and cavitation highlight on page 17 and 18 respectively.

In-Line Control Valves – Model 50R

The Y-globe control valve can be installed in process lines from 1 inch to 24 inches and is ideal to control flow or to reduce pressure. It has a sturdy design, superior flow and control characteristics (compared to globe or ball control valves) and zero leakage sealing performance.



Addressing Fugitive Emissions

SchuF has extensive experience in stuffing box design to minimize emissions to the work area. Typical packing options include PTFE and Graphite with a lantern ring for early leakage detection. A proprietary wiper ring design prevents migration of slurry into the stuffing box area. These elements can be applied to most of the SchuF control valve range.

Globe Control Valve – Model 72

Globe control valves combine the protection of a bellows seal with the controllability and leak tightness of a SchuF control valve. They are used in arduous and lethal services with critical media such as chlorine, phosgene, hydrofluoric acid, NH₃, CO₂, urea etc. They are Eurochlor compliant.

Globe control valves are available in sizes from 1" up to 24", ASME 150# to 900#, in long or short bellows design, in carbon steel, stainless steel, Hastelloy, Monel and Titanium, with pneumatic or electrical controls. All electrical equipment can be explosion proof.

Angle Control Valves

The SchuF control valve product range consists of angle as well as in-line control valves. SchuF has developed over 20,000 control valve variations in its hundred year history. Each has its own specific characteristics tailored to the process control elements that are most important for it – pressure, level, flow or temperature.

X-Flash – Model 74BS

Ideal for **avoiding** flashing in the valve

- Flow to open – External Flashing
- Single stage letdown design
- High Cv values (1 to 3000)
- Low wear and tear
- Disc opening direction eliminates plugging by sediments
- Best suited for vessel installation

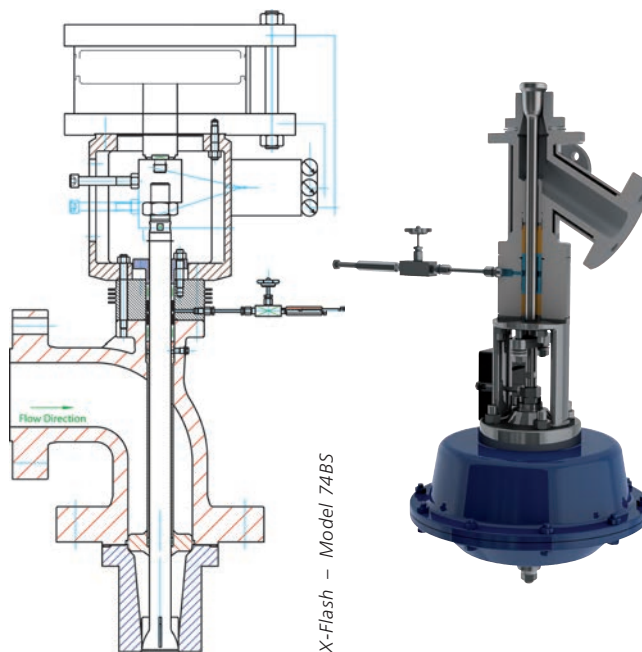

Tough Flash – Model 74CS

Ideal to **accommodate** flashing in the valve

- Flow to close
- Hard material trim
- Flashing occurs in the protected seat / choke tube area
- Up to 180 bar let down is possible in a single stage
- Customised and replaceable choke tube
- Suitable for pipeline or vessel installation

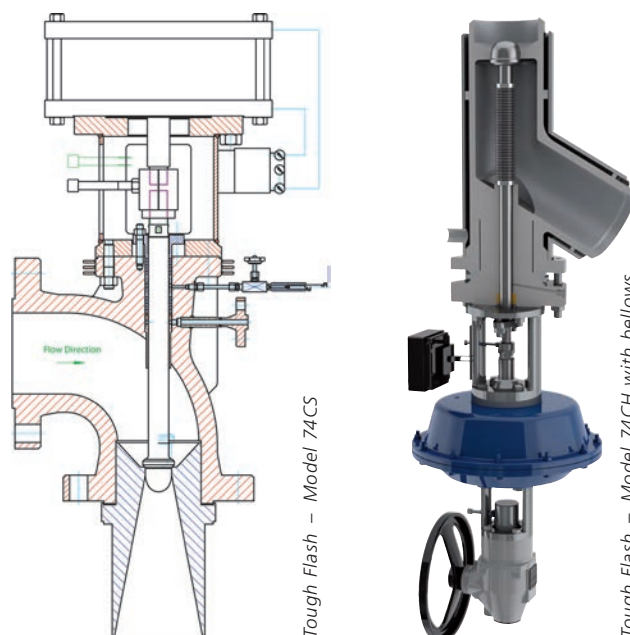

Common SchuF Angle and In-line Control Valve Features:

- Accelerating body geometry design
- Optimised 3 phase flow calculation
- Linear, equal % and SchuF bell X^3 control curve
- Integral plug and stem
- Seat leakage to Class VI, API 598 or EN 60534-4
- Standard robust yoke construction
- Inlet angle 45°, 60° or 90°
- DN 25 (1") to DN 900 (36")

Multi-S – Model 74M

Ideal to let down high pressure over several stages and **avoid cavitation**

- 2, 3 or up to 6 staged pressure reduction disc design
- Up to ASME 2500# as standard
- True Equal % characteristics
- High Cv values (1 to 3000)
- Large outlet chamber to reduce velocities
- Disc opening direction eliminates plugging by catalyst fines or other sediments
- Cast or single block forged body available
- Easy to replace severe service trim

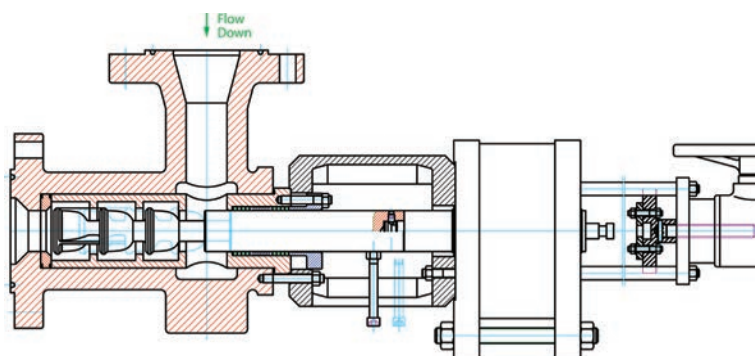

Multi-S – Model 74MS

Cage Release – Model 74K

Ideal for **energy dispersion and noise control**

- Multi hole cage or labyrinth design – to achieve accurate flow characteristics and noise attenuation
- Class VI (API 598) shut-off is achieved, eliminating unacceptable leakage
- Linear or Equal % control characteristics
- Available with fast opening actuators, and smart positioners
- Easy to replace trim parts
- Stainless steel or special hard metal materials can be used

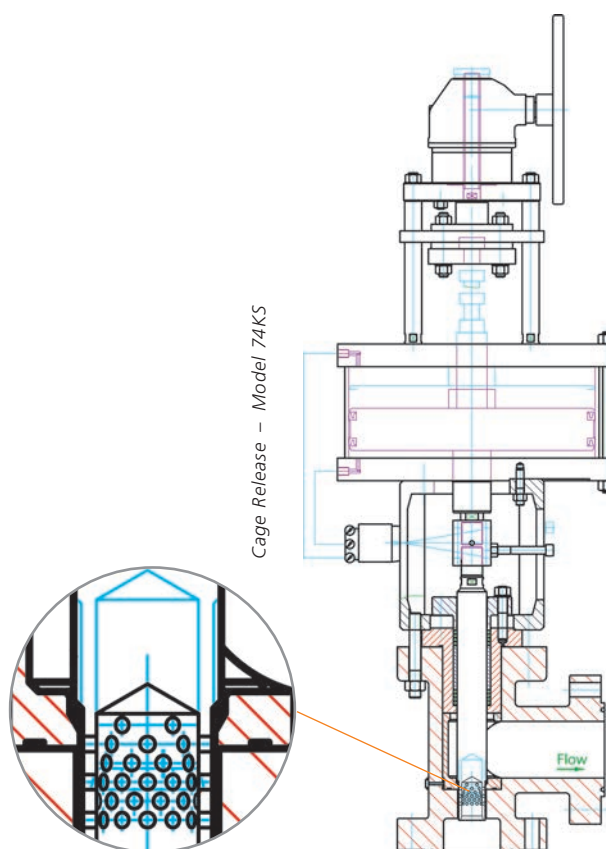

In-Line Control Valves

Y-Globe Control Valve – Model 50

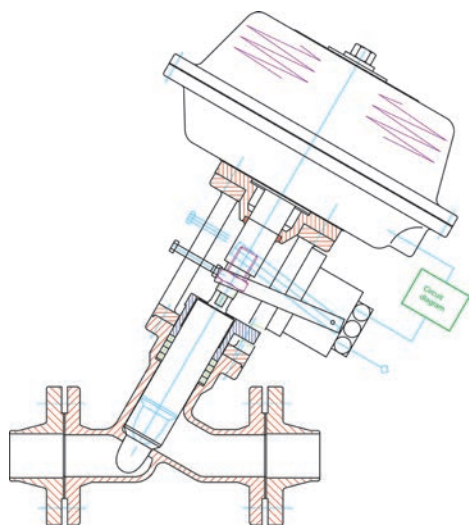

Ideal for in-line control with bubble tight positive shut-off

- High throughput (e.g. 4" (DN 100) – Cv min 140 to max 300)
- Flow optimised – low pressure drop
- Equal %, linear or custom control characteristics
- Class VI process shut-off and zero leakage to atmosphere performance
- Dead and slow space free options

Wafer Control Valve – Model 76

Ideal for limited space control applications

- Space saving design
- Cost optimised
- Linear or equal %
- 1/2 inch to 3 inch
- To ASME 2500#

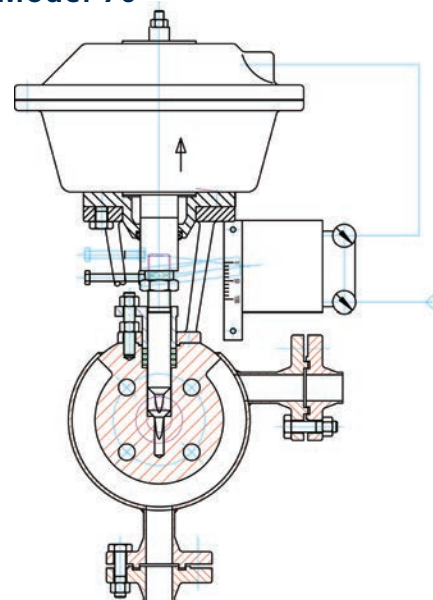

Globe Control Valve – Model 72

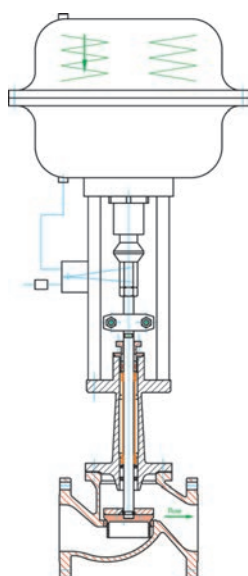

Ideal for lethal service control applications

- Designed for at least 20,000 operations
- Emergency stuffing boxes as standard
- Linear, equal % or on/off control
- Bellows fitted in bonnet to protect against erosion
- Control disc or cage (for noise reduction)
- Loose self aligning disc for absolute shut-off, (ASME Class VI)
- Metallic sealing surfaces with different hardness (e.g. stellite)

Control Valves

Control Valve Flashing Solutions

Control valves used in applications involving liquids in high pressure or high pressure drop conditions are highly susceptible to damage from flashing or cavitation.

Flashing occurs in the liquid flow when the internal pressure of the liquid falls below the vapour pressure and remains below it. During this phase vapour bubbles form and flow with the liquid downstream at increased velocities causing erosion to valves and piping.

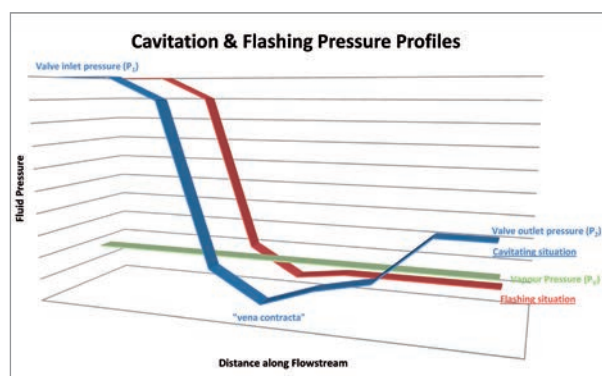

Whilst the variables (P_2 and P_v – see above diagram) that define flashing are not directly controlled by the valve, the best approach for flashing medium is to choose control valves that minimise its effects. SchuF provides a number of anti flashing control features:

■ Particle Impact Prevention

The SchuF Model 74BS is an accelerating flow angle body design with flow to open characteristics. Installed in a tank or vessel the outward opening disc moves any potential flashing to the exit seating area of the valve. Flashing then takes place outside of the valve and the kinetic energy is dissipated into a special tank or vessel.

■ Velocity Reduction

Valves with expanded flow areas downstream of the vena contracta are beneficial as the erosive velocity is reduced. SchuF's angle control valve range either as a flow to open –

X-Flash, or flow to close – ToughFlash (for pipeline installation, where the plug rises into the body) design can be provided with an expanding choke tube or customised outlet. This allows pressure to increase and minimises velocity.

■ Hardened Materials & Surfaces

Correct selection of both the body and trim material can go a long way to reducing the effects of flashing and cavitation.

The synergetic effects of erosion and corrosion in flashing water applications (water corrosion of the steel and flashing erosion of the resultant soft oxide layer for example) can be minimised by selecting a low alloy steel. For more complex flashing media, a wide choice of hard trim materials from ceramic to tungsten carbide, stellite or surface coatings are available to protect the valve.

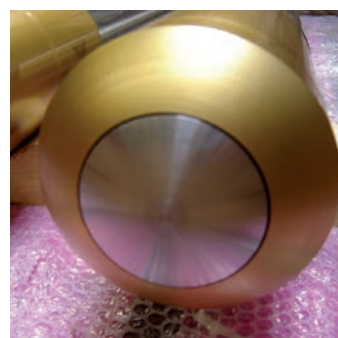

Piston head with tungsten carbide coating

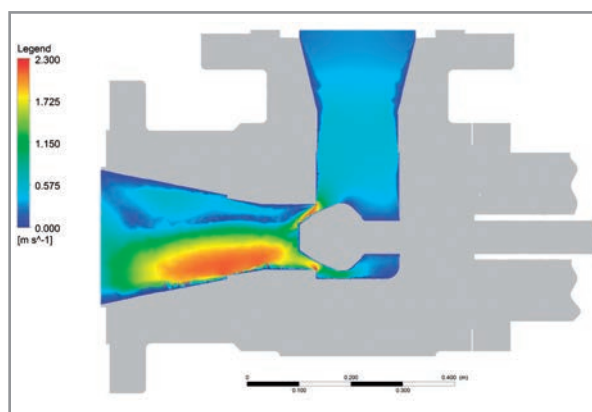

Simulation is at the heart of control valve design for difficult applications. Many negative process consequences such as flashing, crystal formation, or sediment deposits are either avoided or accommodated in SchuF control valve design through extensive use of FEA and CFD (ANSYS) simulation.

Control Valves

Cavitation

Cavitation occurs in a similar way to flashing with the formation of gas bubbles as the liquid pressure falls below vapour pressure. If the liquid pressure then recovers and rises above the vapour pressure the bubbles start to collapse or implode creating a shock wave which releases energy in the form of multiple micro jets.

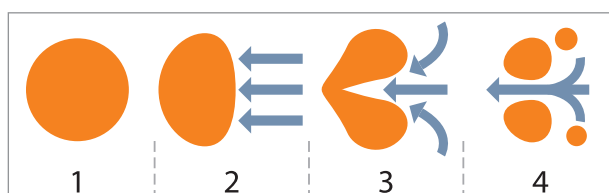

Micro jets have a velocity of 400 km per hour and temperatures of up to 5,500 °C and literally blast away pieces of the valves components or lead to severe pitting and accelerated corrosion. Cavitation is typically accompanied by accentuated hydrodynamic noise and vibrations in the valve and piping.

Anti-Cavitation Solutions

■ Pressure Drop Management

The best means to eliminate cavitation is to control the pressure drop and ensure that it never falls below vapour pressure.

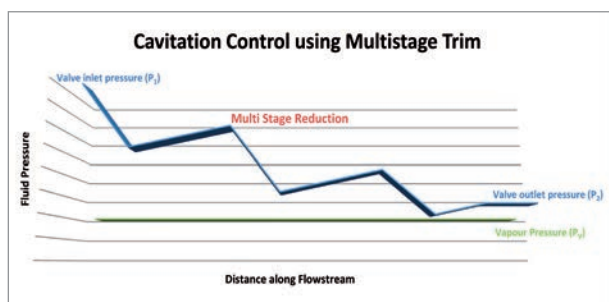

This is achieved by using a multiple stage trim that reduces the pressure drop in stages. The principle is illustrated in the above diagram, where pressure is let down in three successive stages. SchuF has a broad range of multistage trims that allow pressure to be let down in up to six stages in a step plug, or more in a stacked cage design.

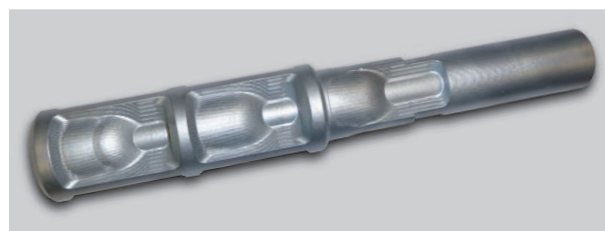

Three stage control plug example

■ Valve Sizing and Design

Proper valve sizing and body or trim design are also important factors in fighting cavitation. SchuF has specialised in the more complex dual and triple phase medium, typically slurries, and has developed its own advanced Cv sizing model for them. The model takes into account pressure drops at minimum, normal, and maximum flows as well as full details of inlet pressure and fluid conditions. The results are referenced against empirical data collected over the past 40 years in exact or similar applications and result in design recommendations for valve, seat and outlet size, body and trim material, as well as trim design for flashing or cavitating applications.

■ Control Valve Diversity

As a result of its focus on real life field control issues SchuF has designed a broad range of both in-line and angle valves. These valves are suitable for critical services as well as severe services that exhibit flashing and cavitation. All SchuF control valves exhibit the following key benefits:

Key Benefits

- Proven critical reliability
- Special design options
- Longer valve life
- Lower maintenance

A full brochure is available at: www.schuf.com/pdf

Automatic Recirculation Valve (ARV) – Model 78

Automatic recirculation valves have the primary purpose of protecting centrifugal pumps by assuring minimum flow through the pump at all times.

Purpose

They replace conventional multi valve pump protection solutions which have proven to be costly or inefficient. The automatic recirculation valve approach unites the check valve, the automatic bypass control valve and pressure letdown functionality in a single valve body.

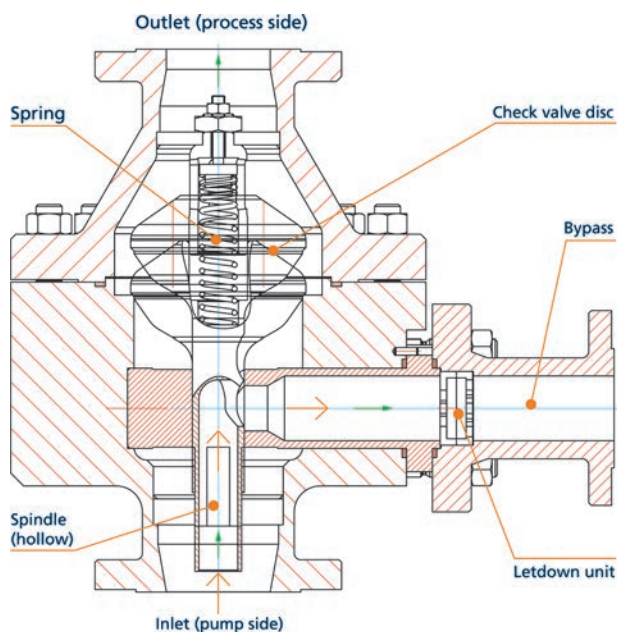

SureFlo™ design

Mode of Operation

The automatic recirculation valve is installed in the pump discharge line in the position of the main check valve that it replaces. The valve opens as soon as the pump builds sufficient flow to move the internal valve disc in the main line into an open position. Decreasing flow through the valve causes the spring loaded disc to return to its seat closing the process outlet.

At the same time the bypass outlet is uncovered allowing a minimum flow of liquid to be routed back to the pump.

A full brochure is available at: www.schuf.com/pdf

Key Features:

- Standard sizes up to 16" (DN 400) and ASME 4500#
- Automatic bypass operation
- Non return function
- Modular design
- Custom pressure letdown in bypass
- No power or air pressure required
- Offshore design available



ARV Product Range

SchuF Fetterolf has a broad range of ARV designs to meet most applications. The **SureFlo™** design is suitable for line sizes up to 10" and ASME 2500# pressure class. The **HighFlo™** goes to 24" and ASME 4500#, whilst the **ControlFlo™** is more suitable for high pressure applications where multistage letdown or enhanced bypass sealing is required.

ARV Pump Applications

- General centrifugal pumps
- Boiler feed water pumps
- Cooling plant feed pumps
- Crude oil pumps
- Fluid gas pumps (LNG, LPG etc.)
- Process liquid pumps
- Booster pumps
- Seawater injection pumps
- Fire fighting pumps

Switching Valves

Diverter Valves – Model 40-49

The diverter valve is a part of the SchuF Fetterolf family of switching valves. Diverter valves split, switch, combine or isolate process media into one or more streams. They can have multiple inlets or outlets or can be bi-directional.

Dead and Slow Space Problems

Dead or slow spaces can lead to many unwelcome consequences. In plastic and polymer production, the end product can be contaminated by particles from previous batches rendering it worthless. In the refinery, dead space can lead to accumulation of coke like particles, catalyst fines or clumps which reduce line capacity and eventually require significant line back flushing.

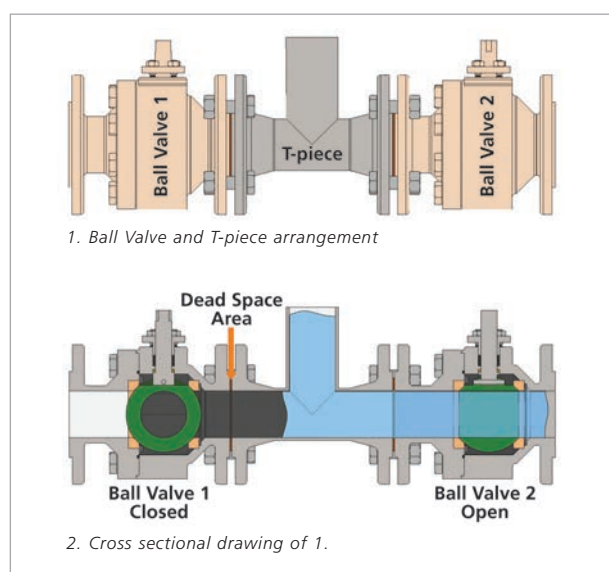

Traditionally, isolation valves interconnected with T-piece piping are used to isolate the process flow in one direction. This is often achieved by using two ball valves and a T-Piece as shown above.

When one of the ball valves is closed and the medium contains solid particles or highly viscous liquids a 'Dead Space' is created by the medium in and around the ball valve and in the left section of the T-piece. The dead space area is shown in the above diagram.

Once the second ball valve is opened, part of the residue that filled the dead space will stick to the piping, thus reducing the full through bore and over time require the valve to be removed for maintenance. Alternatively the residue will form clumps that over time break away to damage other equipment downstream or contaminate the next product batch.

The Diverter Alternative

In the example below a fluid or gas enters the diverter valve through one or more inlets and is either routed to one outlet (the second outlet being isolated), or to both outlets.

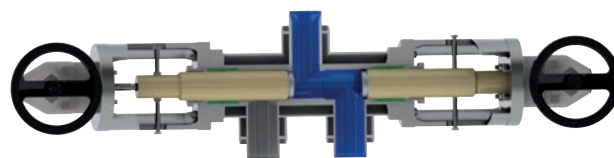

3-Way Diverter Valve – Model 42TK

This is achieved by two actuated pistons or discs that move into the valve body and cover all or part of the outlets from either side. This action results in a completely dead space free valve. The valve is for all intents and purposes a **seamless extension of the plant piping**.

Key Features:

- Sizes: 1" to 24" (larger on request)
- ASME 150# to 2500# as standard
- 3, 4, 5 or multiple inlets/outlets
- Diverse body designs (Y, T, R & S) to match plant piping needs
- Metal to metal positive sealing
- Control characteristics & contoured piston options
- Heating jacket options
- Optional integral flushing ports

Due to their excellent flow properties and in particular the avoidance of slow or dead spaces, diverter valves are ideal for processes with viscous or particle rich media.

A full brochure is available at: www.schuF.com/pdf

Diverter Valve Examples

3 Way Y Type – Model 40YK

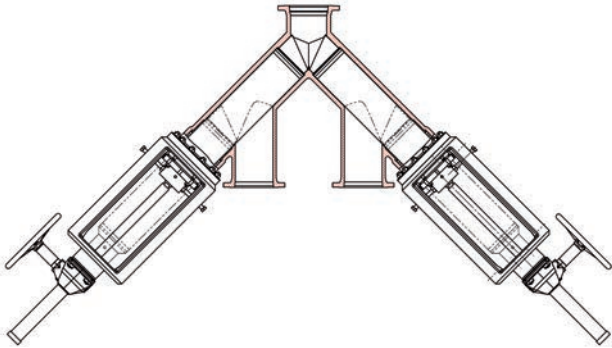

Used in a PBT resin application

4 Way Tangential Star Design – Model 47

Used in a PET application

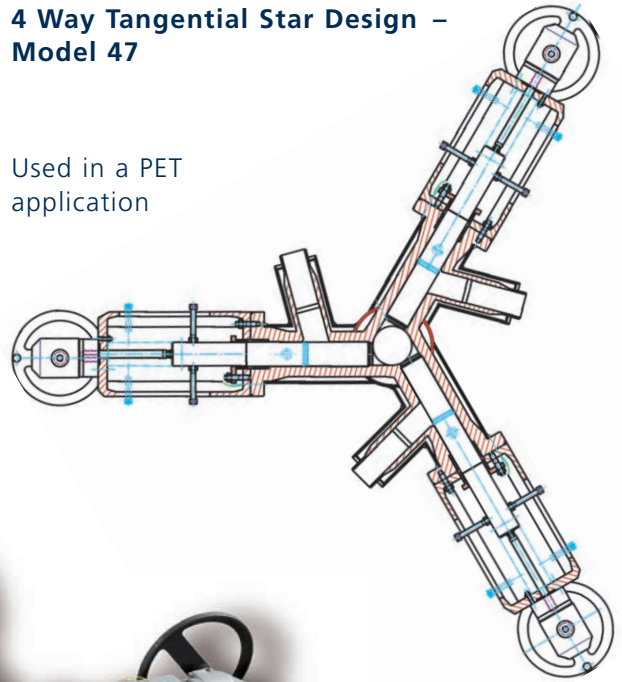

6 Way Star Design – Model 42 FK

Used in a Polycarbonate application

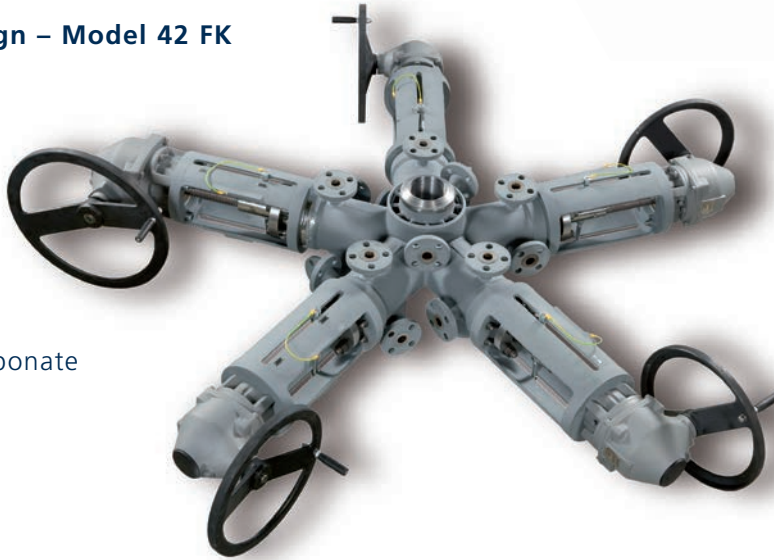

4 Way Type – Model 42DK

Used in a PTA application



5 Way Special – Model 49

Used in a heavy oil upgrading application



Switching Valves

SwitchPlug™ Valve – Model 12SP

The SchuF SwitchPlug valve is a switching valve with typically three outlets and one inlet. It is used to switch media flow from one outlet to another in a defined sequence whilst isolating all other outlets.

It is commonly used in the refining industry for delayed coking due to its leak tight metal to metal sealing characteristics and suitability to high temperatures.



The SwitchPlug consists of only a few moving parts – body, plug and actuator – and is therefore highly reliable. There is no gap between the plug and the valve body where the fluid or coke particles can settle, damage piping or score the valve. Flushing is therefore only required while the plug is in motion.

Key Features:

- Size: 6" (DN150) to 24" (DN600)
- Pressure Class: ASME 150# to 1500#
- 2, 3, or 4 or more outlets
- Full bore round plug design
- High throughput during switching
- Dual motor actuation
- 3 line Sediment Defence System (SDS)
- Integral flushing options

Benefits

Coking Defence System – the SwitchPlug is designed to outperform conventional valves (e.g. ball valves) in services where sediments or coke particles can collect and cause equipment failure. The combination of the gap free design, integrated drain valves and distributed and tangential flushing ensure optimal coke free valve operation.

Y or T design – SchuF can provide the SwitchPlug in either a Y (120°) or T (90°) configuration. This allows for greater piping flexibility, particularly in existing plants or for revamps. The SwitchPlug can also be mounted in horizontal or vertical positions.

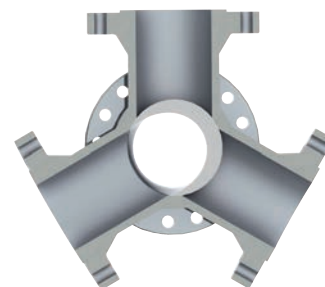

Y configuration, inlet below

Dual Actuation – the SwitchPlug operates with two actuators – one to lift or lower the plug and a second one to rotate it to the required position. The lower torque requirement leads to longer actuator life, reduces maintenance and eliminates plug sticking.

Flow Regulation Mechanism –

the SwitchPlug actuators are provided with an integral control system. This ensures both accurate positioning of the plug to the outlets or bypass line – time and time again. It also enables proportionate distribution of the coke media between two lines or drums e.g. 70% / 30%. Greater than 90% of the flow throughput can be realised even in these intermediate positions.

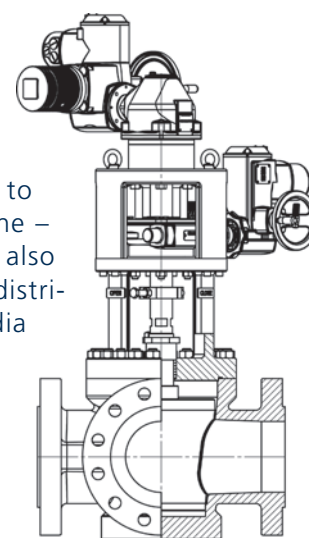

4-Way SwitchPlug Valve

ManiFlow Selector Valve™ – Model 48SZ

The ManiFlow Selector Valve (MSV) has been specifically developed for oil field applications where oil or gas from multiple wells are brought together into one valve body for testing and analysis. Typically the flow from seven wells are connected, but only one is routed via a special plug selector to a test outlet.

The other six are commingled and exit via a large production outlet. Once the first well has been tested, the next or any in a desired sequence of the connected wells can be tested.



Specification

The MSV is available with up to eight inlet ports, one test port and one production outlet. Standard sizes include: 2" / 4", 3" / 6", 4" / 8", 4" / 10" and 6" / 16" in all ASME classes to 1500#. All body materials can be provided with cladding, typically in Incoloy 825. For sour services the lower body half can be in solid Incoloy 825 material. A diverse range of sealing material and options such as flushing ports, locking devices, electronic controller and push button stations are available.

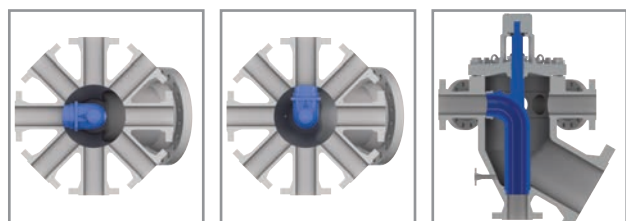

Custom Solutions

SchuF has applied 50 years of diverter and switching valve experience and extensive simulation to solve some of the critical problems found in conventional selector valves and manifolds. These include valve body corrosion, cross contamination between the test and production flows due to leakage, and emissions to atmosphere.

Key Features:

- Compact, modular design
- LeakTight, spring loaded seal
- Field adjustable sealing arrangement
- 1.0° to 1.5° Plug position accuracy
- 3 stage packing for low emission
- Electric actuation, bi-directional 360° operation, multi- or part turn
- Clear user friendly controls
- Integral digital display
- Local, remote or Modbus control
- Removeable hand wheel

Benefits

The SchuF MSV has been designed to reduce the size of pipe manifold arrangements, comprising only one valve and one actuator. In addition the SchuF MSV offers:

- Customised simulation & design
- Longevity – special material combinations that reduce body pitting corrosion
- Superior sealing design that eliminates leakage into the test outlet
- Simplified in-line maintenance

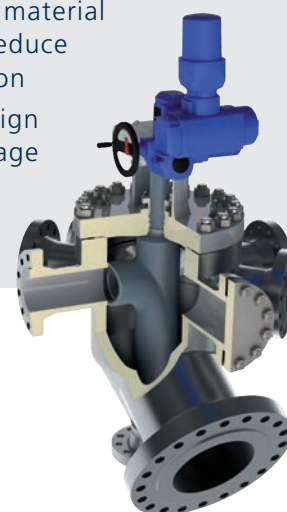

* all wetted parts according to NACE MR0175 or equivalent; leakage class IV; fire safe design on request

Spray Rinse & Injection Valves

Spray Rinse Valve – Model 27SR

The Fetterolf Spray rinse valve was developed to wash residue from large tank or reactor walls without having to open or enter a vessel. This feature has two key benefits: safety of personnel for applications with toxic fluids and to reduce cleaning time in batch processes.

Application

Spray rinse valves can be used to clean vessels after each batch operation. Water, steam, solvents and anti-sticking agents can be injected and are sprayed in a distinct and efficient pattern into the vessel. This leads to longer uninterrupted reactor production cycles and the most cost efficient use of cleaning agents. They are also used in vessel rinsing applications with toxic media in order to ensure personnel safety.

Spray rinse valves are frequently found in the Plastics & Polymer (especially PVC), Fine Chemicals and Pharmaceutical industries.

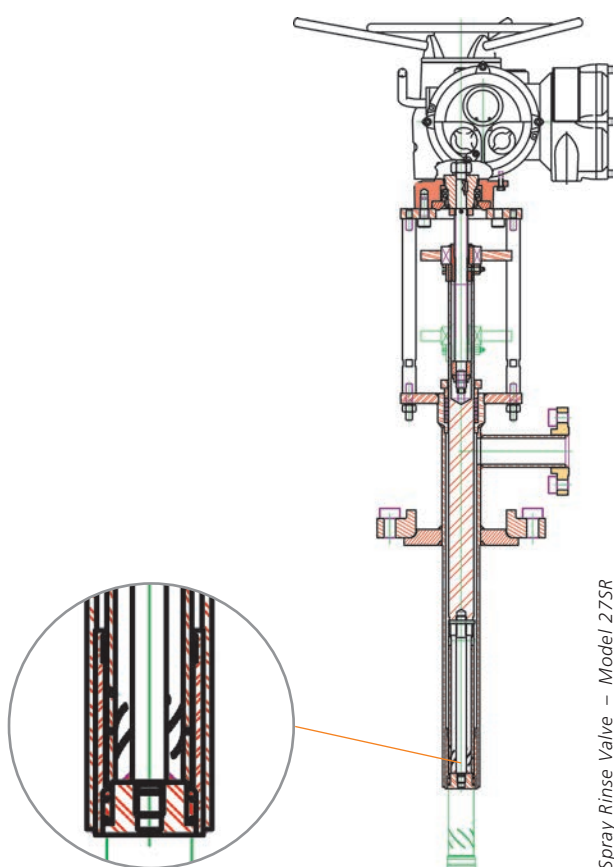

Mode of Operation

In operation, the spray tube assembly is moved out of the valve body to initiate the spray and retracts back into the valve body after the washing cycle. In the closed position the valve disc is flush with the end of the valve body and the spray head is tightly sealed off from the process – and remains clog free.

The device efficiently performs the dual functions of:

1. Shut-off and control of the spray water
2. Direction of the spray in a varying pattern to attain complete wash-down of the residue

The valve can also be used to distribute anti sticking agent.

Key Features:

- Standard sizes 3/4" up to 2" (DN50) and ASME 900#
- Customised spray pattern, pressure & volume
- Zero leakage to atmosphere and process – dual Ram seal design
- Exchangeable seat and spray head
- No clogging guaranteed, due to backflow prevention mechanism
- Rotating or linear spray head
- Electric or pneumatic actuation
- Optional position switches

Rinsing Valve Product Range

Fetterolf provides both a rotary and a linear spray rinse design, with many features customisable to the application requirement.

Benefits

- Increased batch process productivity
- Reduced maintenance
- Protection against toxic emissions
- Optimised water & solvent consumption

Steam Injection Valves – Model 27SE

Steam injection valves are primarily used in the Chemical, Pharmaceutical and Petrochemical industries. They are used to inject steam or any gas into a reactor or vessel.

Application

There are two common applications:

1. Direct and quick pre-heating of media and/or vessels
2. Steam stripping and sanitisation to remove monomers or impurities in polymerisation processes

The choice of a piston or disc injection valve design is process and media driven:

- A solid piston design is suitable for full bore, high flow rate applications with vibrations.
- Disc style injection valves are more suitable where space is limited, the required flow rate is low or where low or zero emissions to atmosphere are important.



27SE Piston injection valve with hollow piston and up to 2000 holes for high flow rates

Key Features:

- Piston or disc valve design
- Metal to metal sealing
- Replaceable seat and injection head
- Customised arrangement of holes for any required gas or vapor injection
- Non clogging

Operation

The valve is typically installed at the bottom of a vessel. Steam is injected into the inlet, flows through the hollow injection stem and exits through up to 2000 dispersion holes.

Constant steam pressure ensures that there is no back-flow and keeps the dispersion holes free of sediment build up.

The valve operates according to a linear step control curve characteristic. This allows a pre-determined number of hole rings to be exposed as required by the process.

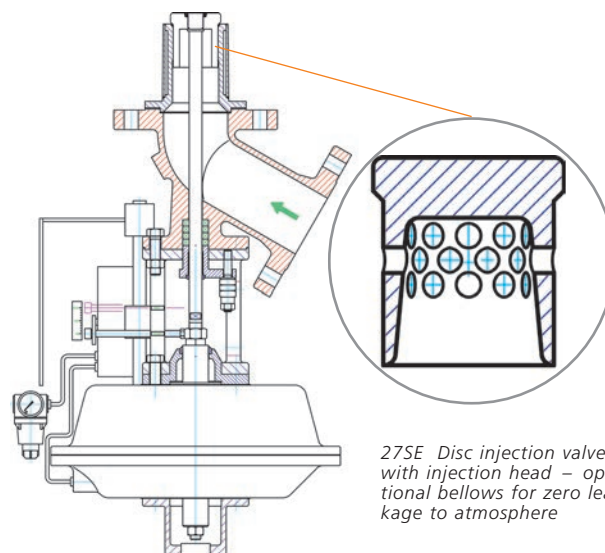

Benefits

- Time saving vessel pre-heating
- Evenly distributed steam pattern
- Step-linear flow rate control
- Optimised steam usage
- Avoids steam hammer effects

Safety Related Valves

Line Blind Valves – Model 81

The ability to isolate pipelines in order to avoid leakage and product cross contamination and to ensure the safety of personnel working on downstream equipment is an essential procedure in industries that store, forward or process hazardous chemical or hydrocarbon substances. Valves can leak downstream. Line blinds do not.

The Schuf Fetterolf Cam-Set® is an advanced line blind system that assures absolute positive line isolation in a convenient, fast and safe way.

Key Features:

- Absolute positive shut-off
- Size up to DN1500 (60")
- ASME 150# to ASME 2500#
- Vast selection of seal types and materials
- Counter weights for larger sizes
- Special coatings for corrosive environments
- Special Offshore design

Applications

Cam-Sets are used in the chemical, petrochemical, refining, paper and pulp and offshore industries. The most common process applications are:

- Flare stack maintenance
- Hydrocarbon pump or loading stations
- Storage terminal isolation
- FPSO, oil & gas tanker and merchant fleet
- Branch line isolation of flammable, corrosive or toxic media
- Blast furnace gas lines

Design Criteria

Cam-Sets are built in strict accordance to international standards such as the ASME Boiler & Pressure Vessel Code – section 8, API 590 (ASME 16.48), API 598, ISO 9001 and – where appropriate – NACE MR0175 and API 2217. Personnel and plant safety are our greatest concern.



Swing type – Cam-Set Model 81FC

Product Range

Schuf Fetterolf has a range of line blinding systems – the swing type or Cam-Set, the sliding type or Cam slide, and the Stacey line blind for dusty or clogging media (such as coal, minerals and slurries).

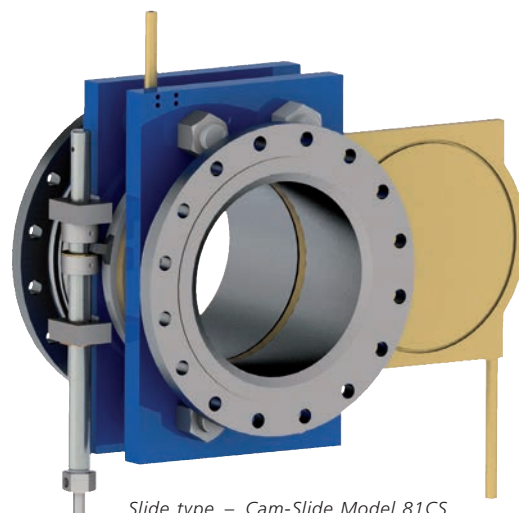

Slide type – Cam-Slide Model 81CS

Benefits

- One man, one side operation
- Fast change – less than 60 seconds
- No flange or line spreading
- No special tools or crane required

Changeover Valves – Models 60-69

Changeover valves enable users to switch process flow from one line to a second line during continuous plant operation. They are primarily used as part of plant safety dual relief systems and are typically installed with pressure relief valves or rupture discs.

They enable maintenance and repair to be carried out safely without disrupting on-going plant operation. The valves are designed to make it impossible to shut off both valve outlets at the same time as required by the ASME Boiler & Pressure Vessel Code.

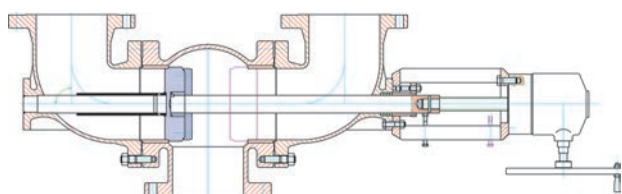

Key Features:

- Size: 1" (DN25) to 14" (DN350)
- Up to ASME 2500#
- Rising / non rising stem design
- Class V or VI process seal
- Low pressure drop (< 3%)
- Multiple packing configurations
- Continuous system overpressure protection
- Temperature range -60° to 700°C

Applications

Changeover valves are primarily located on storage tanks or vessels commonly found in refineries, chemical, petrochemical, or pharmaceutical processing plants. In addition to dual relief in closed discharge systems, they are used in the following applications:

- Switching to & from dual filtration systems
- Selecting between multiple heat exchangers
- In pumping or fluid transfer systems
- Switching from one process line to another
- In manifolding applications

Tandem Changeover Valve

The tandem changeover valve allows for simultaneous selection of the appropriate pressure relief valve and corresponding discharge into a single outlet of a dual relief valve system. One changeover valve is mounted on the riser (inlet) and the other on the outlets of the relief valves. The valves are operated simultaneously through a mechanical chain wheel or rod link.

The linkage between the two pressure relief valves is simple, effective and provides positive and simultaneous switching.

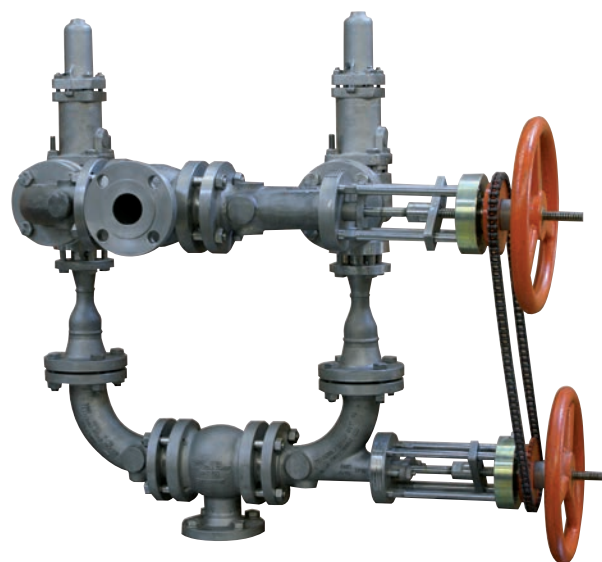

Tandem Changeover Valve – Model 69

Changeover Valve Options

- Contoured discs to avoid dead spaces
- Bellows seal option for zero emissions to atmosphere
- Hardened seat materials e.g. stellite
- Can be partially or fully jacketed
- Chain wheel operator for remote locations

Benefits

- Reduces plant downtime
- Improves process safety
- Reduced pressure drop
- Fast and easy operation

Safety Related Valves

Tank Emergency Shut-Off Valves (TESO) – Models 29 and 73

TESO valves protect large storage tanks in emergency circumstances. They are commonly used in tanks containing toxic or flammable fluids.

Under normal operation conditions the valve is held open by air pressure and in the event of an emergency (e.g. an earthquake or fire) a spring or weight closes the valve.

In-lying TESO valves – Model 73

- Installed from top to the bottom of the tank
- A long spindle connects the pneumatic actuator and disc or plug valve at the bottom
- In case of an emergency a heavy weight moves the disc or plug downwards closing the valve

- 73BH – In-lying disc safety valve
- 73ID – In-lying plug safety valve
- 73IS – Compact TESO design

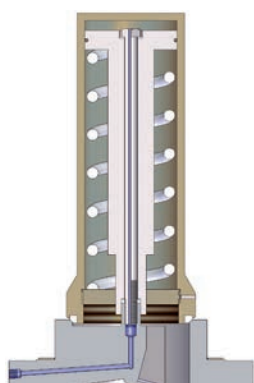

73IS Compact TESO design

TESO for tank side installation

- Extended valve seat bridges the space between the inner and outer tank walls
- 73IH – Side mounted safety disc valve for double wall tanks

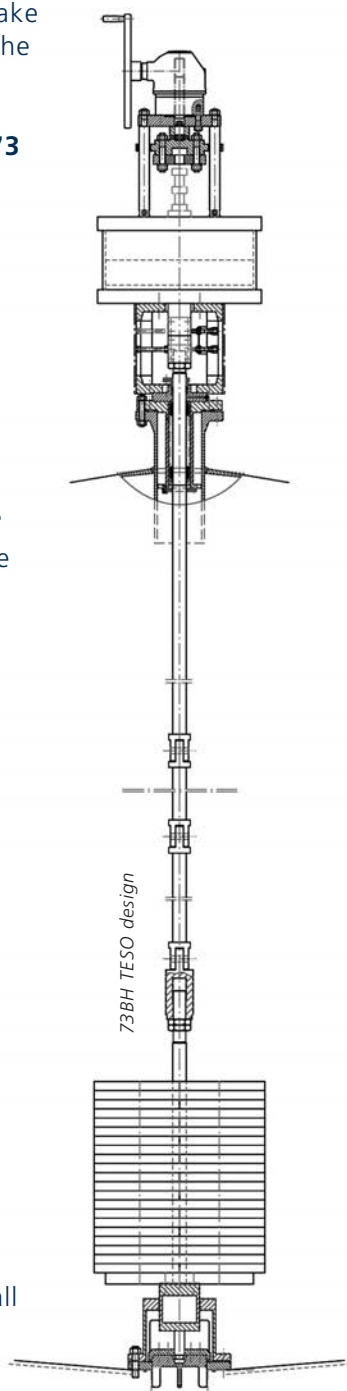

TESO Valves – Key Features:

- The in-lying valve seat is unaffected by damage to pipework or to the valve itself
- Valves can have bellows sealed spindles
- Automatic opening by air pressure
- Suitable for cryogenic services such as liquefied gases

TESO for tank bottom installation – Model 29BH

- Valve seat welded into the vessel bottom
- In emergency cases the spring inside the vessel closes the valve
- The valve disc – that is flush with the tank outlet – is detachable from the valve spindle which is outside the tank wall. This ensures a tight seal even if the outer parts of the valve are damaged
- Optionally with an extended pad seat



29BH TESO with in-lying spring

Product Portfolio Overview

SchuF Fetterolf has delivered over one million valves during its 100 year history to a wide variety of industries in over 50 countries worldwide.

Headquartered near Frankfurt in Germany, the company has additional design and manufacturing centres in Italy, India, Ireland, UK and the USA.

The SchuF group has sales and agent offices covering almost every country in the world.

We manufacture valve products that control, isolate, divert, and sample liquids, gases, powders, and slurries. Our product range of engineered, customised valves includes:

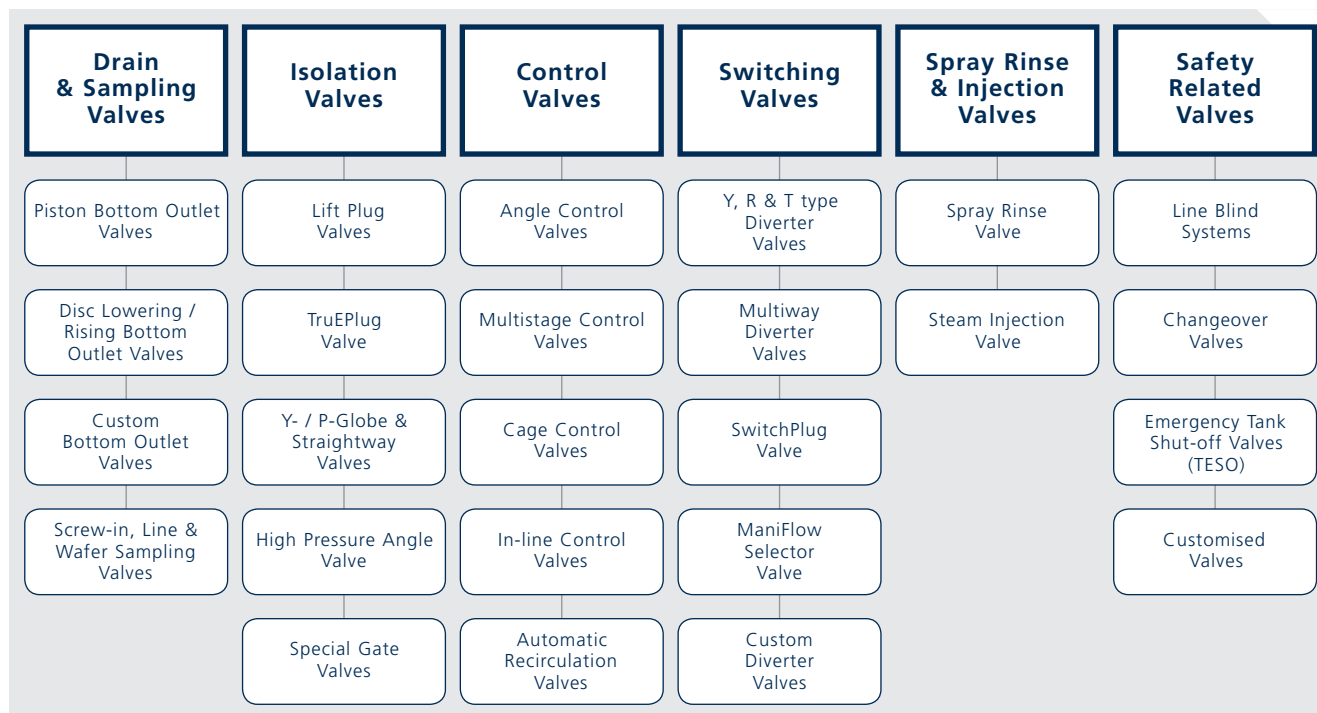

Key Client List:

- | | | |
|------------------|---------------------|------------------|
| ■ AkzoNobel | ■ Glaxo Smith Kline | ■ Reliance |
| ■ AstraZeneca | ■ INEOS | ■ Roche |
| ■ BASF | ■ Invista | ■ SABIC |
| ■ Bayer | ■ Jiangsu Hengli | ■ Saipem |
| ■ BP | ■ Lanxess | ■ Salavat |
| ■ Chevron | ■ LG Chemical | ■ Samsung |
| ■ Clariant | ■ Linde | ■ Sandoz |
| ■ DOW Chemical | ■ Lukoil | ■ Sanofi Aventis |
| ■ Du Pont | ■ Lurgi | ■ Shell |
| ■ Eastman | ■ Merck | ■ Shin Etsu |
| ■ Evonik | ■ Novartis | ■ Sinopec |
| ■ Exxon Chemical | ■ Oerlikon | ■ Sulzer |
| ■ FCFC | ■ Oxy Vinyls | ■ Temex |
| ■ Far Eastern | ■ Pemex | ■ Tuntex |
| ■ Foster Wheeler | ■ Petrobras | ■ Uhde |
| ■ GE | ■ Pfizer | ■ Vinnolit |

