



SERIES 815 ANSI CLASS 150 AND SERIES 830 ASME CLASS 300 WAFER-SPHERE® HIGH PERFORMANCE BUTTERFLY VALVES

Jamesbury® *Wafer-Sphere* high-performance butterfly valves provide long-lasting tight shutoff capability, excellent flow characteristics, and long service life. The following standard sizes are available:

| | | |
|---|------------|--------------|
| 815W (Class 150 Wafer-Body Design) | 2-1/2"–30" | (DN 65–750) |
| 815L (Class 150 Single-Flange Design) | 2-1/2"–60" | (DN 65–1500) |
| F815 (Class 150 Fire-Tested Version) | 3"–60" | (DN 80–1500) |
| 818W (CE Marked Class 150 Wafer-Body Design) | 2-1/2"–30" | (DN 65–750) |
| 818L (CE Marked Class 150 Single Flange Design) | 2-1/2"–30" | (DN 65–750) |
| F818 (CE Marked Class 150 Fire-Tested Version) | 3"–30" | (DN 80–750) |
| 830W (Class 300 Wafer-Body Design) | 3"–30" | (DN 80–750) |
| 830L (Class 300 Single-Flange Design) | 2-1/2"–36" | (DN 65–900) |
| F830 (Class 300 Fire-Tested Version) | 3"–36" | (DN 80–900) |
| 838W (CE Marked Class 300 Wafer-Body Design) | 3"–24" | (DN 80–600) |
| 838L (CE Marked Class 300 Single Flange Design) | 2-1/2"–24" | (DN 65–600) |
| F838 (CE Marked Class 300 Fire-Tested Version) | 3"–24" | (DN 80–600) |

The *Wafer-Sphere* high-performance butterfly valve is available in a range of materials and seat combinations suitable for service in a wide variety of applications including NACE MR0103, and abrasive services. Also available are valves specifically prepared for chlorine, oxygen, and high-vacuum applications.

FEATURES

Field-Proven Single-Piece Flexible Seat Design

- Xtreme® seat provides longer life, expanded performance boundaries, and greater value
- Lip-seal design compensates for temperature and pressure changes
- No additional o-rings or metal parts required to maintain tightness
- Tight shut-off in either direction
- Longer service life with less maintenance

Offset Shaft and Eccentric Disc

- No seat/disc contact in the open or intermediate position
- Eliminates wear points at top and bottom of seats for higher cycle life
- Reduces torque requirements, allowing for smaller operators

Fire-Tested Version Available

- Fire-Tite® *Wafer-Sphere* valves have been tested to API 607 and ISO-10497-5:2004

CE Marked Versions Available

- CE marked and documented valves that conform to the European Pressure Equipment Directive (PED) 97/23/EC are available in ASME Class 150/300, both

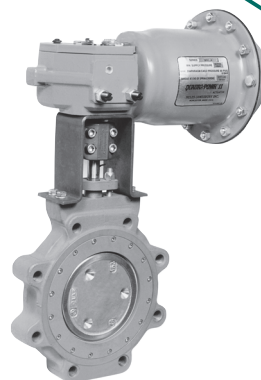

standard and *Fire-Tite* construction. Operating torques, construction options and valve dimensions are exactly the same as the standard ASME 150/300 offering. The applicable sizes for CE marked valves are shown in table to left.

Positive Shaft Retention

- 2-1/2" – 24" (DN 65 – 600) valves are equipped with a retaining ring at the top of the shaft to prevent movement of the top portion of the shaft past the compression ring if for any reason the shaft should break within the valve.

Easy Seat Maintenance

- Simply remove body insert and replace seat – disassembly of disc and shaft is not required

Excellent for both On-Off and Control Applications

- Superior control characteristics
- Inherent flow characteristic is modified equal percentage
- Wide rangeability
- Tight shut-off even in control applications
- Standard lugged style valves are suitable for bi-directional dead-end service at the full pressure-temperature rating of the valve.

Single-Source Responsibility

- Purchase valves, actuators, and accessories, completely mounted from one source
- Available with electric, manual gear, and pneumatic double acting or spring return actuators and a variety of accessories including limit switches, solenoids, and positioners
- OEM service available through world-wide service centers

Available in a Wide Choice of Materials for a Broad Range of Applications

- Standard body materials include carbon steel, stainless steel, Alloy 20, and Monel®. Other materials, such as Avesta® 254SMO are available on application.



ADDITIONAL INFORMATION

Please refer to the bulletins listed below for additional information on other *Jamesbury* high-performance butterfly valves.

Wafer-Sphere polymer (soft) seat HP Butterfly valves

| | |
|-------------------|--------|
| Cryogenic Service | W130-1 |
| Steam Service | W150-1 |
| Chlorine Service | W150-2 |
| Oxygen Service | W150-3 |
| Vacuum Service | W150-4 |
| Jacketed Valves | W151-3 |

SPECIFICATIONS

Valve Seat Ratings

Seat ratings, shown by the graph at right, are based on differential pressure with the *disc in the fully closed position* and refer to **seats** only. Maximum body working pressures are shown in the **Valve Body Ratings** tables below.

Valve Body Ratings

The tables below are maximum working pressure ratings of the **valve body only**. The seat ratings determine the practical pressure limitations according to actual service conditions. Test pressures are for hydrostatic test with disc open.

| Series 815, Class 150 Valve Body Ratings – psi | | | | |
|--|---------------|----------------------|-----------|-------|
| Temp °F | Carbon Steel* | 316 Stainless Steel* | Alloy 20* | Monel |
| -20 to 100 | 285 | 275 | 230 | 230 |
| 200 | 260 | 235 | 200 | 200 |
| 300 | 230 | 215 | 180 | 190 |
| 400 | 200 | 195 | 160 | 185 |
| 500 | 170 | 170 | 150 | 170 |
| Test Pressure | 450 | 425 | 350 | 350 |

| Series 815, Class 150 Valve Body Ratings – bar | | | | |
|--|---------------|----------------------|-----------|-------|
| Temp °C | Carbon Steel* | 316 Stainless Steel* | Alloy 20* | Monel |
| -29 to 38 | 19.6 | 19.0 | 15.9 | 15.9 |
| 100 | 17.7 | 16.2 | 13.5 | 13.7 |
| 150 | 15.8 | 14.8 | 12.3 | 13.1 |
| 200 | 13.8 | 13.7 | 11.3 | 12.8 |
| 250 | 12.1 | 12.1 | 10.4 | 11.9 |
| Test Pressure | 30 | 29 | 24 | 24 |

| Series 830, Class 300 Valve Body Ratings – psi | | | | |
|--|---------------|----------------------|-----------|-------|
| Temp °F | Carbon Steel* | 316 Stainless Steel* | Alloy 20* | Monel |
| -20 to 100 | 740 | 720 | 600 | 600 |
| 200 | 680 | 620 | 520 | 530 |
| 300 | 655 | 560 | 465 | 495 |
| 400 | 635 | 515 | 420 | 480 |
| 500 | 605 | 480 | 390 | 475 |
| Test Pressure | 1125 | 1100 | 900 | 900 |

| Series 830, Class 300 Valve Body Ratings – bar | | | | |
|--|---------------|----------------------|-----------|-------|
| Temp °C | Carbon Steel* | 316 Stainless Steel* | Alloy 20* | Monel |
| -29 to 38 | 51.1 | 49.6 | 41.4 | 41.3 |
| 100 | 46.6 | 42.2 | 35.3 | 36.2 |
| 150 | 45.1 | 38.5 | 32.0 | 34.1 |
| 200 | 43.8 | 35.7 | 29.4 | 33.1 |
| 250 | 41.9 | 33.4 | 27.2 | 32.8 |
| Test Pressure | 77 | 75 | 63 | 63 |

* Ratings correspond to ASME B16.34 for material grades shown in bills of material herein.

Seat Ratings

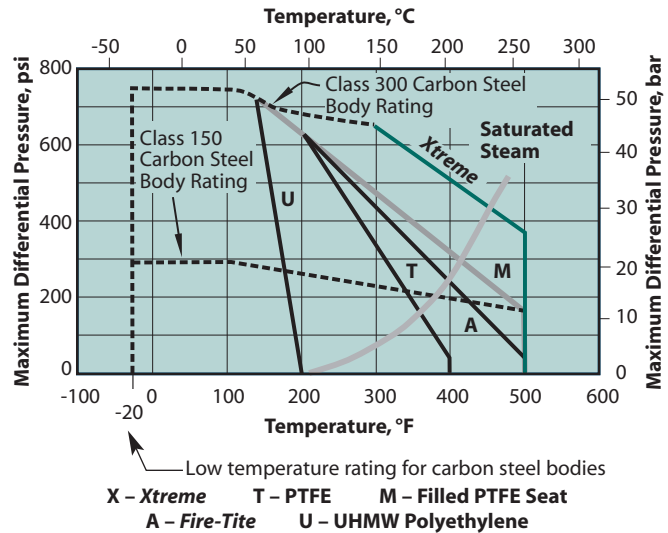

NOTE: 14" – 60" (DN 350 – 1500) Class 150 valves equipped with 316 stainless, Alloy 20 or Hastelloy C shafts are rated for maximum differential pressure of 150 psi (10.35 bar).

3" – 36" (DN 80 – 900) Class 300 valves equipped with 316 stainless, Alloy 20 or Hastelloy C shaft are rated for maximum differential pressure of 300 psi (20.7 bar).

These ratings are a conservative guide for general service. Previous experience in a process or new developments and alternative seat materials may permit applications at ratings above those shown. Please consult our home office for specific recommendations.

Flow Data

The tables below provide flow coefficients for Series 815 and 830 butterfly valves covered in this bulletin. The C_v values represent the number of gallons per minute of +60°F water that flows through a fully open valve at a pressure drop of 1 psi. The metric equivalent, K_v , is the flow of water at 16°C through the valve in cubic meters per hour at a pressure drop of 1 kg/cm². To convert C_v to K_v , multiply by 0.8569. C_v values for partially open valves are given below.

| Series 815 | | |
|------------|------|---------|
| Valve Size | | C_v |
| Inches | DN | |
| 2-1/2 | 65 | 78 |
| 3 | 80 | 165 |
| 4 | 100 | 400 |
| 5 | 125 | 650 |
| 6 | 150 | 1,050 |
| 8 | 200 | 2,200 |
| 10 | 250 | 3,300 |
| 12 | 300 | 5,100 |
| 14 | 350 | 5,800 |
| 16 | 400 | 8,000 |
| 18 | 450 | 10,500 |
| 20 | 500 | 14,000 |
| 24 | 600 | 21,600 |
| 30 | 750 | 34,000 |
| 36 | 900 | 55,500 |
| 42 | 1050 | 82,650 |
| 48 | 1200 | 108,300 |
| 54 | 1350 | 133,500 |
| 60 | 1500 | 159,000 |

| Series 830 | | |
|------------|-----|--------|
| Valve Size | | C_v |
| Inches | DN | |
| 2-1/2 | 65 | 78 |
| 3 | 80 | 165 |
| 4 | 100 | 400 |
| 5 | 125 | 650 |
| 6 | 150 | 1,050 |
| 8 | 200 | 1,800 |
| 10 | 250 | 3,150 |
| 12 | 300 | 4,750 |
| 14 | 350 | 5,200 |
| 16 | 400 | 6,900 |
| 18 | 450 | 9,300 |
| 20 | 500 | 11,300 |
| 24 | 600 | 18,500 |
| 30 | 750 | 29,100 |
| 36 | 900 | 47,500 |

Flow Data (Continued)

To determine C_v values for a valve in an intermediate position: (1) determine the percent of maximum C_v from the graph at right (2) multiply the percent of maximum C_v shown on the graph by the C_v value from the appropriate **Flow Data** table on the previous page.

EXAMPLE: The C_v for a 6" (DN 150) 815 that is 70% open is:

- (1) From the graph, a 6" (DN 150) 815 that is 70% open has a C_v value that is 53% of the maximum C_v .
- (2) 53% of the maximum $C_v = 0.53 \times 1050 = 560$.

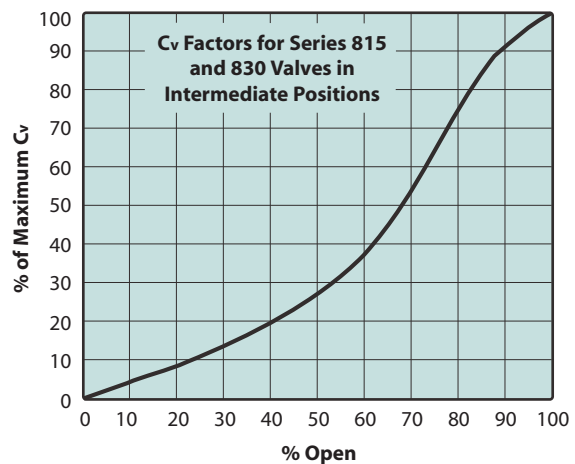

Seat Tightness

ANSI/FCI 70-2 establishes a series of six leakage classes for control valves and defines the test procedure. Class VI allows the least leakage. *Wafer-Sphere* High Performance Butterfly Valves are bubble-tight, MSS-SP61, which would exceed Class VI requirements.

SEAT DESIGNS

Xtreme Performance and Value

Xtreme seats provide longer life, expanded performance boundaries, and the greatest possible value. *Xtreme* is a

unique material that resulted from a technological breakthrough in our polymer research lab. The material is a fluoropolymer-based blend proprietary to *Jamesbury* that provides superior quarter-turn performance.

Standard Seats

Wafer-Sphere standard seat design, constructed of PTFE, Filled PTFE, or UHMW Polyethylene, utilizes a flexible lip, which, when distorted, will always attempt to return to its original shape and maintain a seal against the disc regardless of flow direction.

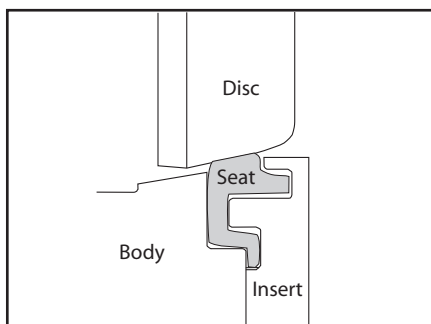

When the valve is shut, the disc slightly deflects the seat. This slight deflection "energizes" the seat. While energized, the sealing surface of the seat is constantly pushing against the edge of the disc.

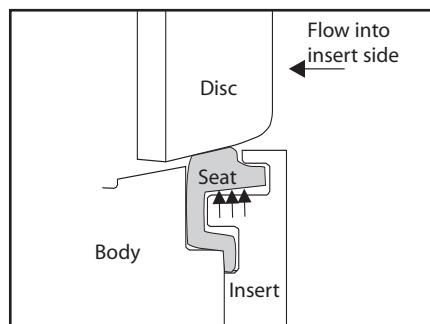

When pressure is on the insert side, pressure is applied under the seat lip. This further amplifies the sealing force between the disc and the seat.

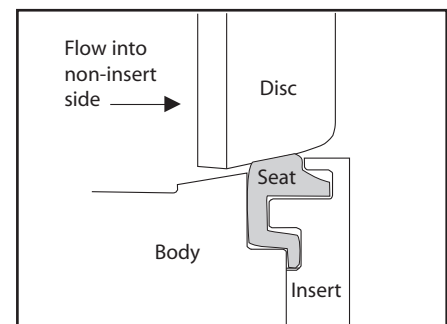

When pressure is on the non-insert side, the disc moves into the seat. Due to the spherical profile of the disc, the more the disc moves into the seat, the tighter the shut-off. Excessive movement of the seat is limited by the flexible lip which contacts the bottom of the groove in the insert ring.

Fire-Tite Seats

The *Fire-Tite* seat was developed for applications where effective shut-off during a fire is a concern. The primary sealing element is *Xtreme* with a back-up metal seat ring. In the event that the *Xtreme* is destroyed, the secondary metal seat provides effective shut-off. The *Fire-Tite* seat is also ideal for critical or severe service applications. *Wafer-Sphere* butterfly valves with *Fire-Tite* seats have been tested and approved to API 607 Edition 5 and to ISO-10497-5:2004.

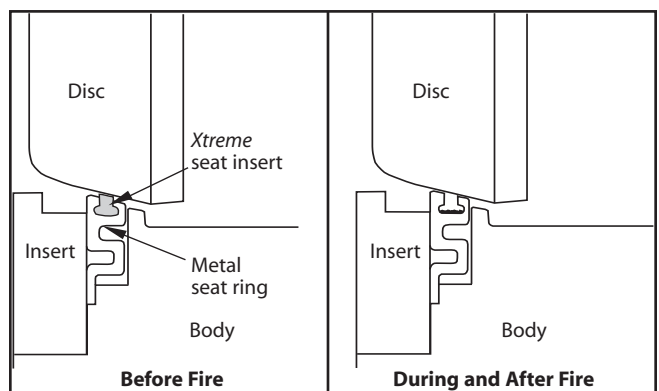

SPECIAL SERVICES

Emission-Pak® Live-Loaded Packing

When enhanced emissions control is needed to comply with evolving emissions standards, *Emission-Pak* live-loaded packing is available. The *Emission-Pak* live-loaded packing assembly includes PTFE V-ring packing live-loaded with disc spring washers for standard construction valves and graphite packing with Inconel disc springs for *Fire-Tite* valves to maintain a constant packing force without overcompression. It is available with new valves or as a retrofit kit for existing valves.

Additional options, available with or without the *Emission-Pak* live-loaded packing, include double packing or double packing with monitoring port to facilitate testing of the primary seal and allow detection of a potential leak problem. Refer to the How to Order section at the end of this bulletin for specific ordering instructions. The **operating torque** of valves with *Emission-Pak* live-loaded packing will increase. (Refer to the torque equation in the Valve Torque Data section).

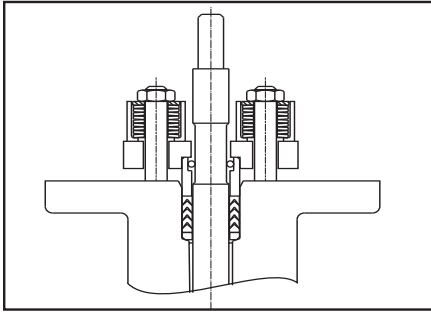

Emission-Pak Live-loaded Packing

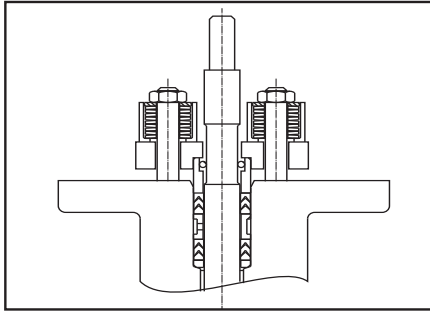

Emission-Pak Live-loaded Packing With Double Packing

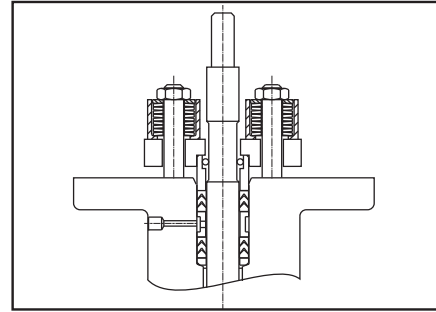

Emission-Pak Live-loaded Packing With Double Packing And Monitoring Port

Note *All *Emission-Pak* illustrations depict a standard valve with PTFE V-ring packing.

Steam Service

Wafer-Sphere butterfly valves are well-suited for a wide range of steam applications. These range from PTFE-seated valves capable of handling lower pressure to valves with *Xtreme* seats. Ratings of *Wafer-Sphere* valves in this bulletin for on-off steam service are as follows: Valves may

that include both on-off operation and proportional control. A rigid procedure is followed in preparing components, assembling, testing, and packaging these valves to assure cleanliness and to avoid the inherent danger of oxygen's reaction with grease, oil, or other foreign matter. Bulletin W150-3 contains additional details.

| Valve Type | Seat Material | Maximum Pressure Differential | |
|------------|---------------|-------------------------------|-----|
| | | psi | bar |
| 815W, 815L | <i>Xtreme</i> | 200* | 14* |
| 830W, 830L | <i>Xtreme</i> | 450 | 31 |

be derated based on shaft material selection.

* Max. rating of carbon steel body per ASME/ANSI B16.34 at corresponding saturated steam temperature.

Cryogenic Service

Using *Wafer-Sphere* with unique polymeric and polymeric/metal composite seats, cryogenic *Wafer-Sphere* valves are rated to give tight, reliable shutoff on service extending from -320°F (-196°C) to ambient condition at pressures up to 1440 psi (99 bar). Cryogenic seats for valve sizes 3" – 12" (DN 80 – 300) are composite. Seats for sizes 14" – 48" (DN 350 – 1200) are Kel-F® material. See Bulletin W130-1.

Chlorine Service

Wafer-Sphere valves reliably control the flow of both liquid and gaseous chlorine. The patented seat design insures positive, leaktight shutoff of this lethal substance. A range of key materials permits selection of the *Wafer-Sphere* valve best suited for the moisture content of the chlorine that is to be handled. Valves for chlorine service are specially cleaned to preclude possible reaction of the chlorine to foreign substances. For further information see Bulletin W150-2.

Oxygen Service

Wafer-Sphere valves are available specially prepared for oxygen service, capable of filling a wide range of applications

NACE Service

ANSI Class 150 and 300 *Wafer-Sphere* valves are available to comply with the NACE MR0103 standard. These valves are well suited for oil and gas industry applications requiring sulfide stress cracking resistant metallic materials.

Abrasive Service

For applications involving slurries or gas-borne solid particles, *Wafer-Sphere* valves are available with the disc hard-coated with tungsten titanium carbide (TTC). Service life of the valve is increased significantly with the assurance of extended sealing capability. This hard coating is also available on application on other valve components that may be subject to wear in other unusual process conditions.

Vacuum Service

Standard *Wafer-Sphere* valves are rated for tight shut-off of vacuum to 2×10^{-2} torr. Special high vacuum *Wafer-Sphere* valves can be provided for vacuums to 1×10^{-5} torr. Additionally, high vacuum valves can be certified to have a leakage rate not to exceed 1×10^{-5} cc/sec. of helium at 1×10^{-5} torr vacuum. Refer to Bulletin W150-4 for details.

High-Cycle Option

Testing in the *Jamesbury* R&D laboratories indicates that a combination of components, including *Xtreme* (X) seat, filled super PTFE shaft seals, 316 SS/Woven PTFE shaft bearings, PEEK®-filled PTFE thrust bearings and excluder rings, yields significantly longer life than a standard configuration valve. Actual cycle performance is subject to media, pressure, and temperature conditions. Applications

such as oxygen, nitrogen, hydrogen, water, and other clean media are ideally suited for this option. **Warning:** Avoid any media containing acids or chemicals such as chlorine, bromine, sulfur dioxide, or steam, or temperatures that exceed 325°F (163°C).

OPERATING HANDLES AND ACTUATORS

As an option, handles are available for smaller sizes of the *Wafer-Sphere* high-performance butterfly valve. We recommend that manual-gear, pneumatic, or electric

actuators be used at differential pressures higher than the values listed below. All handles have locking capability.

| Handle Operated Series 815 | | | | | | | | | | | |
|----------------------------|-----|------------|-------------------------------|------|----------------|------|---------------|-----|---------------|-----|-------------|
| Valve Size | | Valve Type | Maximum Differential Pressure | | | | Handle Length | | Handle Weight | | Handle Code |
| | | | T, M, U or X Seats | | Fire-Tite Seat | | | | | | |
| Inches | DN | | psi | bar | psi | bar | inches | mm | lb. | kg | |
| 2-1/2 | 65 | 815W/815L | 285 | 19.7 | 285 | 19.7 | 11 | 279 | 3 | 1.3 | WSH-36 |
| 3 | 80 | 815W/815L | 285 | 19.7 | 285 | 19.7 | 11 | 279 | 3 | 1.3 | WSH-36 |
| 4 | 100 | 815W/815L | 285 | 19.7 | 285 | 19.7 | 11 | 279 | 3 | 1.3 | WSH-36 |
| 5 | 125 | 815W/815L | 150 | 10.3 | — | — | 11 | 279 | 3 | 1.3 | WSH-36 |
| 6 | 150 | 815W/815L | 150 | 10.3 | — | — | 11 | 279 | 3 | 1.3 | WSH-38 |
| 8 | 200 | 815W/815L | 150 | 10.3 | — | — | 22 | 559 | 15 | 6.8 | WSH-23 |
| 10 | 250 | 815W/815L | 50 | 3.4 | — | — | 22 | 559 | 15 | 6.8 | WSH-24 |
| 12 | 300 | 815W/815L | 50 | 3.4 | — | — | 22 | 559 | 15 | 6.8 | WSH-25 |

| Handle Operated Series 830 | | | | | | | | | | | |
|----------------------------|-----|------------|-------------------------------|------|----------------|------|---------------|-----|---------------|-----|-------------|
| Valve Size | | Valve Type | Maximum Differential Pressure | | | | Handle Length | | Handle Weight | | Handle Code |
| | | | T, M, U or X Seats | | Fire-Tite Seat | | | | | | |
| Inches | DN | | psi | bar | psi | bar | inches | mm | lb. | kg | |
| 2-1/2 | 65 | 830L | 300 | 20.7 | — | — | 11 | 279 | 3 | 1.3 | WSH-36 |
| 3 | 80 | 830W/830L | 300 | 20.7 | 300 | 20.7 | 11 | 279 | 3 | 1.3 | WSH-36 |
| 4 | 100 | 830W/830L | 300 | 20.7 | 300 | 20.7 | 11 | 279 | 3 | 1.3 | WSH-36 |
| 5 | 125 | 830L | 300 | 20.7 | — | — | 11 | 279 | 3 | 1.3 | WSH-38 |
| 6 | 150 | 830W/830L | 150 | 10.3 | — | — | 22 | 559 | 15 | 6.8 | WSH-23 |
| 8 | 200 | 830W/830L | 150 | 10.3 | — | — | 22 | 559 | 15 | 6.8 | WSH-24 |
| 10 | 250 | 830W/830L | 50 | 3.4 | — | — | 22 | 559 | 15 | 6.8 | WSH-25 |

| Materials of Construction for Handle Kits | | | |
|---|--------------------|------------------|----------------------------|
| Part Number* | Part Name | Handle Code | |
| | | WSH-36 WSH-38 | WSH-23 WSH-24 WSH-25 |
| H1 | Handle Subassembly | Stainless steel | Malleable iron |
| H2 | Ratchet | Stainless steel | Carbon steel |
| H3 | Cap Screw | Stainless steel | Carbon steel |
| H4 | Lock Washer | — | Carbon steel |
| H5 | Hex Nut | — | Carbon steel |
| H6 | Cap Screw | Stainless steel | Carbon steel |
| H7 | Lock Washer | Stainless steel | Carbon steel |

* Refer to drawing on pages 11 and 12.

VALVE TORQUE DATA

The torque required to open or close the Series 815 and Series 830 can easily be calculated using the equation on the following page. However, for your convenience, the following tables can be used as a quick guide for actuator selection. If the valve's torque is not listed in the tables,

use the equation on next page to calculate the torque. Refer to other bulletins for pneumatic and electric actuators. Select an actuator that provides the same or greater torque output than the valve's torque. **If in doubt, select the next larger actuator.**

| Valve Size | | Torque – Series 815 Shaft Downstream; T, M, U, & X Seats | | | | | |
|------------|------|---|------------------|---------------------|-------------------|---------------------|-------------------|
| | | Shut-off Differential Pressure | | | | | |
| Inches | DN | FT•LBS @ 100 psi | N•m @ 6.9 bar | FT•LBS @ 200 psi | N•m @ 13.8 bar | FT•LBS @ 285 psi | N•m @ 19.7 bar |
| 2-1/2 | 65 | 21 | 29 | 23 | 31 | 24 | 33 |
| 3 | 80 | 25 | 34 | 27 | 37 | 29 | 39 |
| 4 | 100 | 35 | 47 | 39 | 53 | 43 | 58 |
| 5 | 125 | 48 | 65 | 56 | 76 | 63 | 86 |
| 6 | 150 | 72 | 97 | 83 | 113 | 93 | 126 |
| 8 | 200 | 121 | 164 | 142 | 193 | 160 | 217 |
| 10 | 250 | 163 | 222 | 202 | 274 | 234 | 318 |
| 12 | 300 | 214 | 290 | 287 | 390 | 350 | 475 |
| 14 | 350 | 362 | 491 | 505 | 684 | 626 | 849 |
| 16 | 400 | 463 | 628 | 646 | 876 | 802 | 1087 |
| 18 | 450 | 602 | 816 | 844 | 1144 | 1050 | 1423 |
| 20 | 500 | 810 | 1098 | 1140 | 1546 | 1421 | 1926 |
| 24 | 600 | 1234 | 1673 | 1758 | 2384 | 2200 | 2983 |
| 30 | 750 | 2170 | 2942 | 2940 | 3986 | 3595 | 4873 |
| 36 | 900 | 3530 | 4786 | 4860 | 6589 | 5990 | 8121 |
| 42 | 1050 | 5780 | 7837 | 8060 | 10928 | 10000 | 13558 |
| 48 | 1200 | 9170 | 12433 | 12840 | 17409 | 15960 | 21638 |
| 54 | 1350 | 12950 | 17558 | 17900 | 24269 | 22110 | 29977 |
| 60 | 1500 | 19020 | 25790 | 26040 | 35310 | 32000 | 43397 |

| Valve Size | | Torque – Series F815 Shaft Downstream or Upstream; All Fire-Tite Seats | | | | | |
|------------|------|---|------------------|---------------------|-------------------|---------------------|-------------------|
| | | Shut-off Differential Pressure | | | | | |
| Inches | DN | FT•LBS @ 100 psi | N•m @ 6.9 bar | FT•LBS @ 200 psi | N•m @ 13.8 bar | FT•LBS @ 285 psi | N•m @ 19.7 bar |
| 2-1/2 | 65 | 42 | 57 | 45 | 61 | 47 | 64 |
| 3 | 80 | 53 | 72 | 57 | 77 | 59 | 81 |
| 4 | 100 | 67 | 91 | 74 | 100 | 80 | 108 |
| 5 | 125 | 97 | 132 | 114 | 155 | 128 | 174 |
| 6 | 150 | 131 | 178 | 152 | 206 | 170 | 230 |
| 8 | 200 | 218 | 296 | 256 | 347 | 288 | 391 |
| 10 | 250 | 333 | 452 | 406 | 550 | 468 | 635 |
| 12 | 300 | 508 | 689 | 636 | 862 | 745 | 1010 |
| 14 | 350 | 604 | 819 | 758 | 1028 | 889 | 1205 |
| 16 | 400 | 710 | 963 | 920 | 1247 | 1099 | 1489 |
| 18 | 450 | 970 | 1315 | 1370 | 1857 | 1710 | 2318 |
| 20 | 500 | 1390 | 1885 | 1980 | 2685 | 2482 | 3364 |
| 24 | 600 | 2050 | 2779 | 2700 | 3661 | 3353 | 4410 |
| 30 | 750 | 2920 | 3959 | 3940 | 5342 | 4807 | 6517 |
| 36 | 900 | 3530 | 4786 | 4960 | 6725 | 6176 | 8373 |
| 42 | 1050 | 5620 | 7620 | 7440 | 10087 | 8987 | 12185 |
| 48 | 1200 | 8800 | 11931 | 12100 | 16405 | 14905 | 20208 |

| Valve Size | | Torque – Series 830 Shaft Downstream; T, M, U, & X Seats | | | | | | | | | | | |
|------------|-----|---|-------------------|---------------------|-------------------|---------------------|-------------------|---------------------|-------------------|---------------------|-------------------|---------------------|-----------------|
| | | Shut-off Differential Pressure | | | | | | | | | | | |
| Inches | DN | FT•LBS @ 300 psi | N•m @ 20.7 bar | FT•LBS @ 400 psi | N•m @ 27.6 bar | FT•LBS @ 500 psi | N•m @ 34.5 bar | FT•LBS @ 600 psi | N•m @ 41.4 bar | FT•LBS @ 700 psi | N•m @ 48.3 bar | FT•LBS @ 740 psi | N•m @ 51 bar |
| 2-1/2 | 65 | 25 | 34 | 27 | 36 | 30 | 41 | 33 | 45 | 35 | 47 | 36 | 49 |
| 3 | 80 | 31 | 42 | 34 | 46 | 38 | 51 | 41 | 55 | 44 | 60 | 45 | 62 |
| 4 | 100 | 52 | 70 | 58 | 79 | 65 | 88 | 72 | 97 | 78 | 106 | 81 | 110 |
| 5 | 125 | 85 | 115 | 98 | 132 | 112 | 151 | 125 | 169 | 138 | 186 | 143 | 193 |
| 6 | 150 | 119 | 161 | 138 | 188 | 158 | 214 | 178 | 241 | 197 | 267 | 205 | 278 |
| 8 | 200 | 231 | 313 | 271 | 368 | 312 | 422 | 352 | 477 | 392 | 532 | 408 | 554 |
| 10 | 250 | 354 | 480 | 422 | 572 | 490 | 664 | 557 | 756 | 625 | 848 | 652 | 885 |
| 12 | 300 | 492 | 667 | 582 | 790 | 673 | 913 | 764 | 1035 | 854 | 1158 | 890 | 1207 |
| 14 | 350 | 824 | 1117 | 1012 | 1372 | 1200 | 1627 | 1388 | 1882 | 1576 | 2137 | 1651 | 2239 |
| 16 | 400 | 989 | 1340 | 1212 | 1643 | 1435 | 1946 | 1658 | 2248 | 1881 | 2550 | 1970 | 2671 |
| 18 | 450 | 1279 | 1734 | 1562 | 2118 | 1845 | 2502 | 2128 | 2885 | 2411 | 3269 | 2524 | 3422 |
| 20 | 500 | 1707 | 2314 | 2096 | 2842 | 2485 | 3369 | 2874 | 3897 | 3263 | 4424 | 3419 | 4635 |
| 24 | 600 | 2309 | 3131 | 2832 | 3840 | 3355 | 4549 | 3878 | 5258 | 4401 | 5967 | 4610 | 6251 |
| 30 | 750 | 4210 | 5708 | 5080 | 6888 | 5950 | 8067 | 6820 | 9247 | 7690 | 10426 | 8038 | 10898 |
| 36 | 900 | 7220 | 9789 | 8760 | 11877 | 10300 | 13965 | 11840 | 16053 | 13380 | 18141 | 13996 | 18976 |

VALVE TORQUE DATA (CONTINUED)

| Valve Size | | Torque – Series F830 Shaft Upstream or Downstream; All Fire-Tite Seats | | | | | | | | | | | |
|------------|-----|---|-------------------|---------------------|-------------------|---------------------|-------------------|---------------------|-------------------|---------------------|-------------------|---------------------|-----------------|
| | | Shut-off Differential Pressure | | | | | | | | | | | |
| Inches | DN | FT•LBS @ 300 psi | N•m @ 20.7 bar | FT•LBS @ 400 psi | N•m @ 27.6 bar | FT•LBS @ 500 psi | N•m @ 34.5 bar | FT•LBS @ 600 psi | N•m @ 41.4 bar | FT•LBS @ 700 psi | N•m @ 48.3 bar | FT•LBS @ 740 psi | N•m @ 51 bar |
| 3 | 80 | 57 | 77 | 58 | 79 | 60 | 81 | 61 | 83 | 63 | 85 | 63 | 86 |
| 4 | 100 | 86 | 117 | 94 | 127 | 102 | 138 | 110 | 149 | 118 | 160 | 121 | 164 |
| 6 | 150 | 189 | 256 | 212 | 287 | 235 | 319 | 258 | 350 | 281 | 381 | 290 | 394 |
| 8 | 200 | 313 | 424 | 354 | 480 | 395 | 536 | 436 | 591 | 477 | 647 | 493 | 669 |
| 10 | 250 | 464 | 629 | 522 | 708 | 580 | 786 | 638 | 865 | 696 | 944 | 719 | 975 |
| 12 | 300 | 825 | 1119 | 960 | 1302 | 1095 | 1485 | 1230 | 1668 | 1365 | 1851 | 1419 | 1924 |
| 14 | 350 | 922 | 1250 | 1076 | 1459 | 1230 | 1668 | 1384 | 1877 | 1538 | 2085 | 1600 | 2169 |
| 16 | 400 | 1170 | 1586 | 1390 | 1885 | 1610 | 2183 | 1830 | 2481 | 2050 | 2779 | 2138 | 2899 |
| 18 | 450 | 1980 | 2685 | 2440 | 3308 | 2900 | 3932 | 3360 | 4556 | 3820 | 5179 | 4004 | 5429 |
| 20 | 500 | 2800 | 3796 | 3460 | 4691 | 4120 | 5586 | 4780 | 6481 | 5440 | 7376 | 5704 | 7734 |
| 24 | 600 | 4400 | 5966 | 5400 | 7321 | 6400 | 8677 | 7400 | 10033 | 8400 | 11389 | 8800 | 11931 |

TORQUE EQUATION

Use the following equation to calculate the torque required to open and close the Series 815 and Series 830 valves.

Torque required (FT•LBS) = (Kt multiplied by the shut-off differential pressure in psi) + Ts

EXAMPLE: 6" (DN 150) 815W-11-36HBMT at 230 psi (15.9 bar) differential pressure, installed shaft downstream = (0.116 X 230) + 60 = 87 FT•LBS.

To convert FT•LBS to N•m, multiply by 1.356.

| Valve Size | | Class 150 | | | | | Class 300 | | | | |
|------------|------|-------------------------------|------------------------|-------|---------------------------------------|------|-------------------------------|------------------------|------|---------------------------------------|------|
| | | Series 815 T, M, U, & X Seats | | | Series 815 Fire-Tite | | Series 830 T, M, U, & X Seats | | | Series 830 Fire-Tite | |
| Inches | DN | Kt Shaft Upstream | Kt Shaft Downstream | Ts | Kt Shaft Upstream or Downstream | Ts | Kt Shaft Upstream | Kt Shaft Downstream | Ts | Kt Shaft Upstream or Downstream | Ts |
| 2-1/2 | 65 | 0.017 | 0.014 | 20 | 0.024 | 40 | 0.027 | 0.026 | 17 | — | — |
| 3 | 80 | 0.021 | 0.021 | 23 | 0.033 | 50 | 0.034 | 0.033 | 21 | 0.015 | 52 |
| 4 | 100 | 0.046 | 0.046 | 30 | 0.07 | 60 | 0.068 | 0.066 | 32 | 0.08 | 62 |
| 5 | 125 | 0.105 | 0.081 | 40 | 0.13 | 65 | 0.130 | 0.125 | 47 | — | — |
| 6 | 150 | 0.156 | 0.116 | 60 | 0.21 | 110 | 0.203 | 0.196 | 60 | 0.23 | 120 |
| 8 | 200 | 0.301 | 0.211 | 100 | 0.38 | 180 | 0.423 | 0.403 | 110 | 0.41 | 190 |
| 10 | 250 | 0.584 | 0.384 | 125 | 0.73 | 260 | 0.689 | 0.679 | 150 | 0.58 | 290 |
| 12 | 300 | 0.847 | 0.737 | 140 | 1.28 | 380 | 1.106 | 0.906 | 220 | 1.35 | 420 |
| 14 | 350 | 2.034 | 1.424 | 220 | 1.54 | 450 | 2.28 | 1.88 | 260 | 1.54 | 460 |
| 16 | 400 | 2.88 | 1.83 | 280 | 2.1 | 500 | 3.21 | 2.23 | 320 | 2.2 | 510 |
| 18 | 450 | 3.65 | 2.42 | 360 | 4.0 | 570 | 3.94 | 2.83 | 430 | 4.6 | 600 |
| 20 | 500 | 4.72 | 3.30 | 480 | 5.9 | 800 | 5.01 | 3.89 | 540 | 6.6 | 820 |
| 24 | 600 | 7.34 | 5.24 | 710 | 7.5 | 1400 | 6.88 | 5.23 | 740 | 10 | 1400 |
| 30 | 750 | 11.2 | 7.7 | 1400 | 12.0 | 1900 | 9.4 | 8.7 | 1600 | — | — |
| 36 | 900 | 20.4 | 13.3 | 2200 | 21.0 | 2400 | 16.1 | 15.4 | 2600 | — | — |
| 42 | 1050 | 29.9 | 22.8 | 3500 | 31.0 | 3800 | — | — | — | — | — |
| 48 | 1200 | 43.7 | 36.7 | 5500 | 45.0 | 5700 | — | — | — | — | — |
| 54 | 1350 | 59.5 | 49.5 | 8000 | — | — | — | — | — | — | — |
| 60 | 1500 | 80.7 | 70.2 | 12000 | — | — | — | — | — | — | — |

Note: The Ts value for a valve with *Emission-Pak* Live-Loaded Packing will increase. For valves with Live-Loaded PTFE shaft packing, use (Ts x 1.06). For valves with Live-Loaded Graphite shaft packing, use (Ts x 1.26).

| BILLS OF MATERIALS AND PARTS LIST | | | | |
|-----------------------------------|--|---|-------------------------------------|--|
| Series 815 | | | | |
| Part No. | Part Name | Type 815_2236 815_22HB F815_2236 F815_22HB | Type 815_2271 F815_2271 | Type 815_3600 815_36HB F815_3600 F815_36HB |
| 1 | Body | Carbon steel ASTM A216, Type WCB | | 316 Stainless steel ASTM A351, Type CF8M |
| 2 | Insert | Carbon steel | | 316 Stainless steel |
| 3 | Disc | 316 Stainless steel | Monel | 316 Stainless steel |
| 4 | Shaft | 316 Stainless steel (2236) or 17-4 PH Stainless steel (22HB) | | 316 Stainless steel (3600) or 17-4 PH SS (36HB) |
| 5 | Seat† | See page 19 for seat codes | | |
| 6 | Shaft Bearing | PTFE composite backed with 316 Stainless steel | PTFE composite backed with Monel | PTFE composite backed with 316 Stainless steel |
| 7 | Spacer | Stainless steel | Monel | Stainless steel |
| 8 | Shaft Seal† | See page 19 for seal codes | | |
| 9 | Compression Ring | 316 Stainless steel | | |
| 10 | Compression Plate | Carbon steel | | 316 Stainless steel |
| 13 | Disc Pin | Same material as shaft | | |
| 14 | Stud | Carbon steel | | Stainless steel |
| 15 | Nut | Carbon steel | | Stainless steel |
| 16 | Lock Washer (16" [DN 400] and larger only) | Carbon steel | | Stainless steel |
| 17 | Name Plate | Stainless steel | | |
| 18 | Drive Screw | Stainless steel | | |
| 21 | Cap Screw (815L & 14" – 60" [DN 350 – 1500] 815W) | Stainless steel | | |
| 26 | Indicator Plate (42" – 60" [DN 1050 – 1500] only) | Stainless steel | | |
| 27 | Drive Screw (42" – 60" [DN 1050 – 1500] only) | Stainless steel | | |
| 29 | Indicator Pointer (16" – 60" [DN 400 – 1500] only) | Carbon steel | | |
| 40 | Body Seal† | PTFE (2-1/2" – 4" [DN 65 – 100] standard 815Ls only) or graphite (3" – 12" [DN 80 – 300] <i>Fire-Tite</i>) | | |
| 41 | Top Bearing Spacer (2-1/2" – 10" [DN 65 – 250]) | PTFE | | |
| 47 | Retaining Ring (2-1/2" – 36" [DN 65 – 900] only) | Inconel® | | |
| 53 | Cover Plate (14" – 36" [DN 350 – 900]) | Stainless steel or Carbon steel (<i>Fire-Tite</i>) | | Stainless steel |
| 54 | Gasket (14" – 60" [DN 350 – 1500] only) | PTFE or graphite (<i>Fire-Tite</i>) | | |
| 55 | Cap Screw (14" – 60" [DN 350 – 1500] only) | Stainless steel or Carbon steel (<i>Fire-Tite</i>) | | Stainless steel |
| 56 | Lock Washer (14" – 60" [DN 350 – 1500] only) | Carbon steel | | Stainless steel |
| 64 | Thrust Bearing | 316 Stainless steel | Monel | 316 Stainless steel |
| 77 | Insert Spring (2-1/2" – 12" [DN 65 – 300] 815Ws) | Inconel | | |

† Recommended spare part

| BILLS OF MATERIALS AND PARTS LIST | | | | |
|--|--|--|--|--|
| Series 815 | | | | |
| Part No. | Part Name | Type 815_3500 F815_3500 | Type 815_3635 F815_3635 | Type 815_7100 F815_7100 |
| 1 | Body | Alloy 20 Stainless steel ASTM A351-Type CN7M | 316 Stainless steel ASTM A351-Type CF8M | Monel ASTM A494 |
| 2 | Insert | Alloy 20 | 316 Stainless steel | Monel |
| 3 | Disc | Alloy 20 | | Monel |
| 4 | Shaft | Alloy 20 | | Monel |
| 5 | Seat† | See page 19 for seat codes | | |
| 6 | Shaft Bearing | PTFE composite backed with Alloy 20 Stainless steel | | PTFE composite backed with Monel |
| 7 | Spacer | Alloy 20 | | Monel |
| 8 | Shaft Seal† | See page 19 for seal codes | | |
| 9 | Compression Ring | | 316 Stainless steel | |
| 10 | Compression Plate | 316 Stainless steel | 316 Stainless steel | Monel |
| 13 | Disc Pin | Same material as shaft | | |
| 14 | Stud | Stainless steel | | Monel |
| 15 | Nut | Stainless steel | | Monel |
| 16 | Lockwasher (16" [DN 400] and larger) | Carbon steel | | Monel |
| 17 | Name Plate | Stainless steel | | |
| 18 | Drive Screw | Stainless steel | | |
| 21 | Cap Screw (815L & 14" – 60" [DN 350 – 1500] 815W) | Stainless steel | | Monel |
| 26 | Indicator Plate (42" – 60" [DN 1050 – 1500] only) | Stainless steel | | |
| 27 | Drive Screw (42" – 60" [DN 1050 – 1500] only) | Stainless steel | | |
| 29 | Indicator Pointer (16" – 60" [DN 400 – 1500] only) | Carbon steel | | |
| 40 | Body Seal† | PTFE (2-1/2" – 4" [DN 65–100] standard 815Ls only) or graphite (3" – 12" [DN 80 – 300]) (<i>Fire-Tite</i>) | | |
| 41 | Top Bearing Spacer (2-1/2" – 10" [DN 65 – 250]) | PTFE | | |
| 47 | Retaining Ring (2-1/2" – 36" [DN 65 – 900]) | Inconel | | |
| 53 | Cover Plate (14" – 60" [DN 350 – 1500] only) | Alloy 20 | Stainless steel | Monel |
| 54 | Gasket (14" – 60" [DN 350 – 1500] only) | PTFE or graphite (<i>Fire-Tite</i>) | | |
| 55 | Cap Screw (14" – 60" [DN 350 – 1500] only) | Stainless steel | | Monel |
| 56 | Lock Washer (14" – 60" [DN 350 – 1500] only) | Stainless steel | | Monel |
| 64 | Thrust Bearing | Alloy 20 | | Monel |
| 77 | Insert Spring (2-1/2" – 12" [DN 65 – 300] 815Ws) | Inconel | | |

† Recommended spare part

| BILLS OF MATERIALS AND PARTS LIST | | | | | |
|-----------------------------------|---|--|-------------------------------------|---|--|
| Series 830 | | | | | |
| Part No. | Part Name | Type 830_22HB F830_22HB | Type 830_2271 F830_2271 | Type 830_36HB F830_36HB | Type 830_3635 F830_3635 |
| 1 | Body | Carbon steel (3" – 12" [DN 80 – 300]) ASTM A216, Type WCB [14" – 24" [DN 350 – 600]) | | 316 Stainless steel ASTM A351, Type CF8M | |
| 2 | Insert | Carbon steel | | 316 Stainless steel | |
| 3 | Disc | 316 Stainless steel | Monel | 316 Stainless steel | Alloy 20 |
| 4 | Shaft | 17-4 PH Stainless steel | Monel | 17-4 PH SS | Alloy 20 |
| 5 | Seat† | See page 19 for seat codes | | | |
| 6 | Shaft Bearing | PTFE composite backed with 316 SS | PTFE composite backed with Monel | PTFE composite backed with 316 SS | PTFE composite backed with Alloy 20 |
| 7 | Spacer | Stainless steel | Monel | 316 Stainless steel | Alloy 20 |
| 8 | Shaft Seal† | See page 19 for seal codes | | | |
| 9 | Compression Ring | 316 Stainless steel | | | |
| 10 | Top Compression Plate | Carbon steel | | 316 Stainless steel | |
| 13 | Disc Pin | Same material as shaft | | | |
| 14 | Stud | Carbon steel | | Stainless steel | |
| 15 | Nut | Carbon steel | | Stainless steel | |
| 16 | Lock Washer (14" – 36" [DN 350 – 900] only) | Carbon steel | | | |
| 17 | Name Plate | Stainless steel | | | |
| 18 | Drive Screw | Stainless steel | | | |
| 21 | Cap Screw (830L & 14" – 24" [DN 350 – 600] 830W) | Stainless steel | | | |
| 26 | Indicator Plate (30" – 36" [DN 750 – 900]) | Stainless steel | | | |
| 27 | Drive Screw (30" – 36" [DN 750 – 900]) | Stainless steel | | | |
| 29 | Indicator Pointer (14" – 36" [DN 350 – 900]) | Carbon steel | | | |
| 40 | Body Seal† | PTFE (3" – 4" [DN 80 – 100] standard 830L only) or graphite (3" – 12" [DN 80 – 100] <i>Fire-Tite</i>) | | | |
| 41 | Top Bearing Spacer (except 12" [DN 15]) | PTFE | | | |
| 43 | Bottom Bearing Spacer (14" – 16" [DN 350 – 400] only) | PTFE | | | |
| 47 | Retaining Ring (3" – 24" [DN 80 – 600] only) | Inconel | | | |
| 53 | Cover Plate | Carbon steel | | 316 Stainless steel | |
| 54 | Gasket | PTFE or graphite (<i>Fire-Tite</i>) | | | |
| 55 | Cap Screw | Carbon steel | | Stainless steel | |
| 56 | Lock Washer | Carbon steel | | Stainless steel | |
| 64 | Thrust Bearing | 316 Stainless steel | Monel | 316 Stainless steel | Alloy 20 |
| 77 | Insert Spring (2-1/2" – 12" [DN 65 – 300] 830W only) | Inconel | | | |

† Recommended spare part

DIMENSIONS

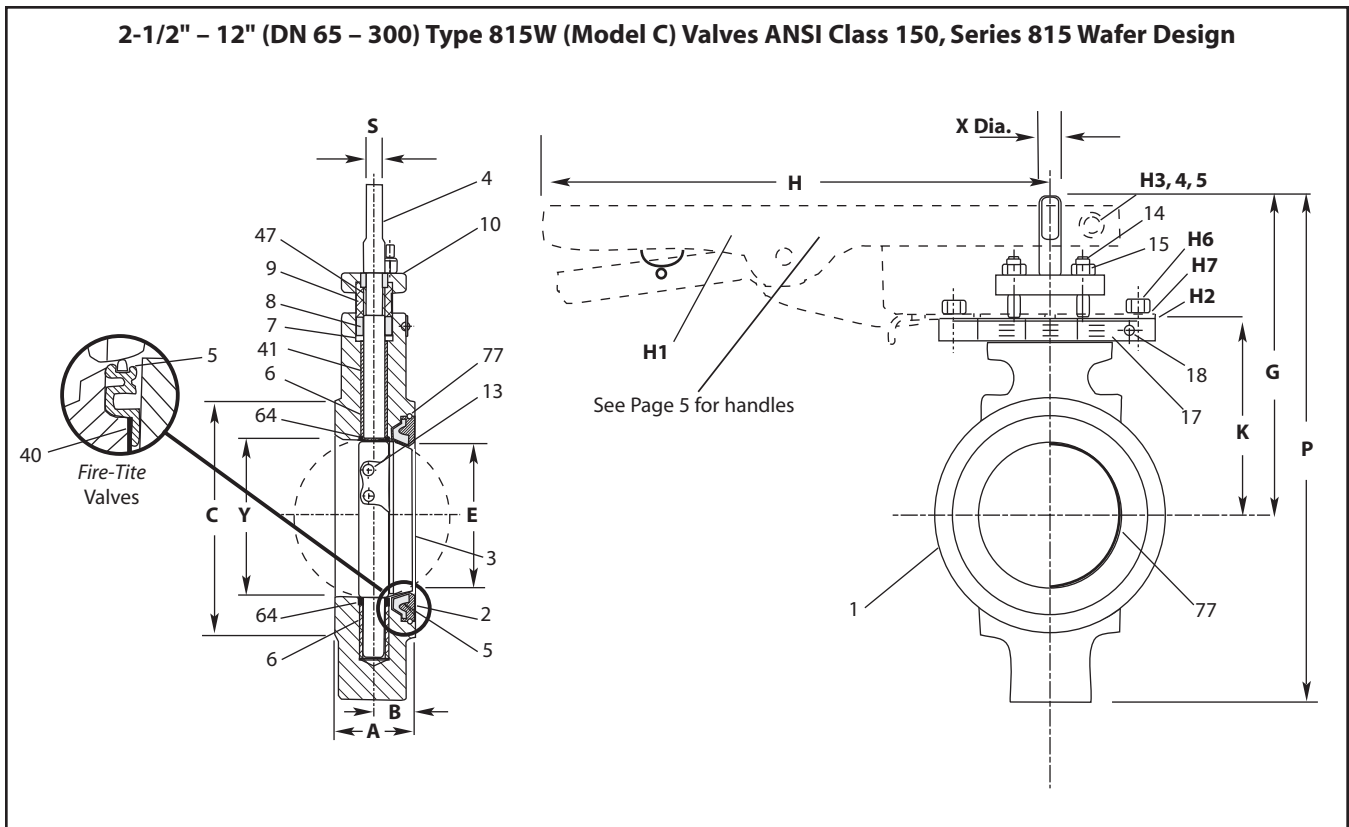

| Valve Size inches | Approximate Dimensions - inches | | | | | | | | | | | Approx. Weight lbs.** |
|-------------------|---------------------------------|------|-------|-------|-------|-------|-------|-------|---------|------|-------|-----------------------|
| | A | B | C | E | G | H | K | P | S Blade | X | Y* | |
| 2-1/2 | 1.94 | 1.06 | 4.69 | 2.31 | 7.63 | 11.00 | 4.38 | 10.81 | 0.44 | 0.63 | 1.88 | 11 |
| 3 | 1.94 | 1.06 | 5.19 | 2.88 | 8.00 | 11.00 | 4.75 | 12.44 | 0.44 | 0.63 | 2.90 | 13 |
| 4 | 2.13 | 1.19 | 6.19 | 3.75 | 8.50 | 11.00 | 5.25 | 13.44 | 0.44 | 0.63 | 3.83 | 18 |
| 5 | 2.50 | 1.19 | 7.31 | 4.38 | 8.56 | 11.00 | 5.31 | 14.25 | 0.44 | 0.63 | 4.38 | 27 |
| 6 | 2.25 | 1.31 | 8.50 | 5.59 | 9.25 | 11.00 | 6.00 | 15.13 | 0.53 | 0.75 | 5.76 | 28 |
| 8 | 2.50 | 1.41 | 10.63 | 7.41 | 10.63 | 22.00 | 7.38 | 18.25 | 0.63 | 0.88 | 7.63 | 45 |
| 10 | 2.81 | 1.63 | 12.75 | 9.28 | 12.81 | 22.00 | 9.13 | 22.06 | 0.81 | 1.13 | 9.56 | 78 |
| 12 | 3.19 | 1.88 | 15.00 | 11.09 | 14.13 | 22.00 | 10.25 | 24.88 | 0.94 | 1.38 | 11.37 | 112 |

* Conforms to API 609 and MSS-SP 68 requirements for minimum clearances of pipe inside diameters for Schedule 80 pipe.

** Weights do not include handles. See page 5 for handle weights

| Valve Size DN | Approximate Dimensions - mm | | | | | | | | | | | Approx. Weight kg ** |
|---------------|-----------------------------|----|-----|-----|-----|-----|-----|-----|---------|----|-----|----------------------|
| | A | B | C | E | G | H | K | P | S Blade | X | Y* | |
| 65 | 49 | 27 | 119 | 59 | 194 | 279 | 111 | 275 | 11 | 16 | 48 | 5 |
| 80 | 49 | 27 | 132 | 73 | 203 | 279 | 121 | 316 | 11 | 16 | 74 | 6 |
| 100 | 54 | 30 | 157 | 95 | 216 | 279 | 133 | 341 | 11 | 16 | 97 | 8 |
| 125 | 64 | 30 | 186 | 111 | 217 | 279 | 135 | 362 | 11 | 16 | 111 | 12 |
| 150 | 57 | 33 | 216 | 142 | 235 | 279 | 152 | 384 | 13 | 19 | 146 | 13 |
| 200 | 64 | 36 | 270 | 188 | 270 | 559 | 187 | 464 | 16 | 22 | 194 | 20 |
| 250 | 71 | 41 | 324 | 236 | 325 | 559 | 232 | 560 | 21 | 29 | 243 | 35 |
| 300 | 81 | 48 | 381 | 282 | 359 | 559 | 260 | 632 | 24 | 35 | 289 | 51 |

* Conforms to API 609 and MSS-SP 68 requirements for minimum clearances of pipe inside diameters for Schedule 80 pipe.

** Weights do not include handles. See page 5 for handle weights

DIMENSIONS (CONTINUED)

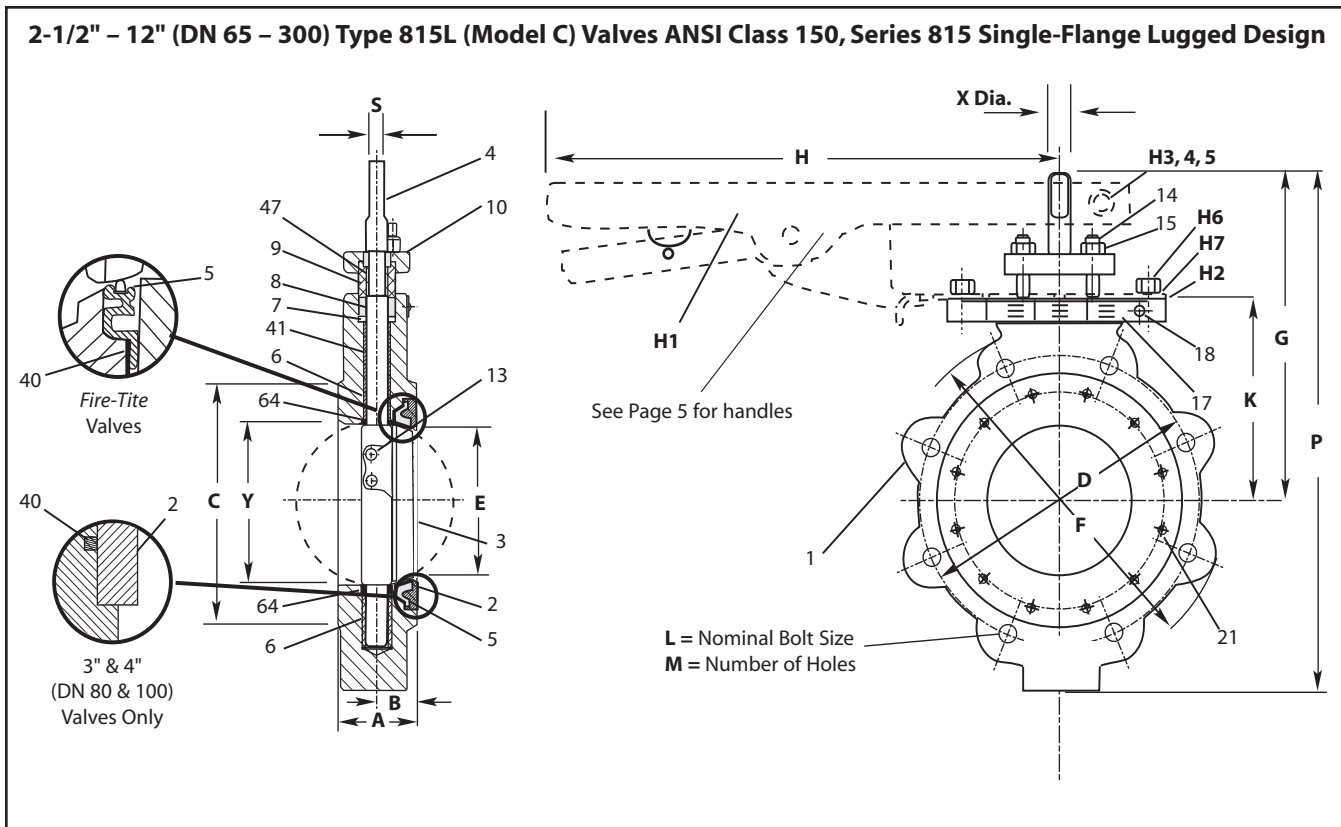

| Valve Size inches | Approximate Dimensions – inches | | | | | | | | | | | | | | | Approx. Weight lbs.** |
|-------------------|---------------------------------|------|-------|-------|-------|-------|-------|-------|-------|--------|----|-------|---------|------|-------|-----------------------|
| | A | B | C | D | E | F | G | H | K | L | M | P | S Blade | X | Y* | |
| 2-1/2 | 1.94 | 1.06 | 4.13 | 5.50 | 2.31 | 7.00 | 7.63 | 11.00 | 4.38 | 5/8-11 | 4 | 10.81 | 0.44 | 0.63 | 1.88 | 15 |
| 3 | 1.94 | 1.06 | 5.19 | 6.00 | 2.88 | 7.50 | 8.00 | 11.00 | 4.75 | 5/8-11 | 4 | 12.44 | 0.44 | 0.63 | 2.90 | 17 |
| 4 | 2.13 | 1.19 | 6.19 | 7.50 | 3.75 | 9.00 | 8.50 | 11.00 | 5.25 | 5/8-11 | 8 | 13.44 | 0.44 | 0.63 | 3.83 | 26 |
| 5 | 2.50 | 1.19 | 7.31 | 8.50 | 4.38 | 10.38 | 8.56 | 11.00 | 5.31 | 3/4-10 | 8 | 13.44 | 0.44 | 0.63 | 4.38 | 40 |
| 6 | 2.25 | 1.31 | 8.50 | 9.50 | 5.59 | 11.00 | 9.25 | 11.00 | 6.00 | 3/4-10 | 8 | 15.13 | 0.53 | 0.75 | 5.76 | 43 |
| 8 | 2.50 | 1.41 | 10.63 | 11.75 | 7.41 | 13.50 | 10.63 | 22.00 | 7.38 | 3/4-10 | 8 | 18.25 | 0.63 | 0.88 | 7.63 | 69 |
| 10 | 2.81 | 1.63 | 12.75 | 14.25 | 9.28 | 16.00 | 12.81 | 22.00 | 9.13 | 7/8-9 | 12 | 22.06 | 0.81 | 1.13 | 9.56 | 92 |
| 12 | 3.19 | 1.88 | 15.00 | 17.00 | 11.09 | 19.00 | 14.13 | 22.00 | 10.25 | 7/8-9 | 12 | 24.88 | 0.94 | 1.38 | 11.37 | 140 |

* Conforms to API 609 and MSS-SP 68 requirements for minimum clearances of pipe inside diameters for Schedule 80 pipe.

** Weights do not include handles. See page 5 for handle weights

| Valve Size DN | Approximate Dimensions – mm | | | | | | | | | | | | | | | Approx. Weight kg ** |
|---------------|-----------------------------|----|-----|-----|-----|-----|-----|-----|-----|--------|----|-----|---------|----|-----|----------------------|
| | A | B | C | D | E | F | G | H | K | L | M | P | S Blade | X | Y* | |
| 65 | 49 | 27 | 105 | 140 | 59 | 178 | 194 | 279 | 111 | 5/8-11 | 4 | 275 | 11 | 16 | 48 | 7 |
| 80 | 49 | 27 | 132 | 152 | 73 | 191 | 203 | 279 | 121 | 5/8-11 | 4 | 316 | 11 | 16 | 74 | 8 |
| 100 | 54 | 30 | 157 | 191 | 95 | 229 | 216 | 279 | 133 | 5/8-11 | 8 | 341 | 11 | 16 | 97 | 12 |
| 125 | 64 | 30 | 186 | 216 | 111 | 264 | 217 | 279 | 135 | 3/4-10 | 8 | 341 | 11 | 16 | 111 | 18 |
| 150 | 57 | 33 | 216 | 241 | 142 | 279 | 235 | 279 | 152 | 3/4-10 | 8 | 384 | 13 | 19 | 146 | 20 |
| 200 | 64 | 36 | 270 | 298 | 188 | 343 | 270 | 559 | 187 | 3/4-10 | 8 | 464 | 16 | 22 | 194 | 31 |
| 250 | 71 | 41 | 324 | 362 | 236 | 406 | 325 | 559 | 232 | 7/8-9 | 12 | 560 | 21 | 29 | 243 | 42 |
| 300 | 81 | 48 | 381 | 432 | 282 | 483 | 359 | 559 | 260 | 7/8-9 | 12 | 632 | 24 | 35 | 289 | 64 |

* Conforms to API 609 and MSS-SP 68 requirements for minimum clearances of pipe inside diameters for Schedule 80 pipe.

** Weights do not include handles. See page 5 for handle weights.

DIMENSIONS (CONTINUED)

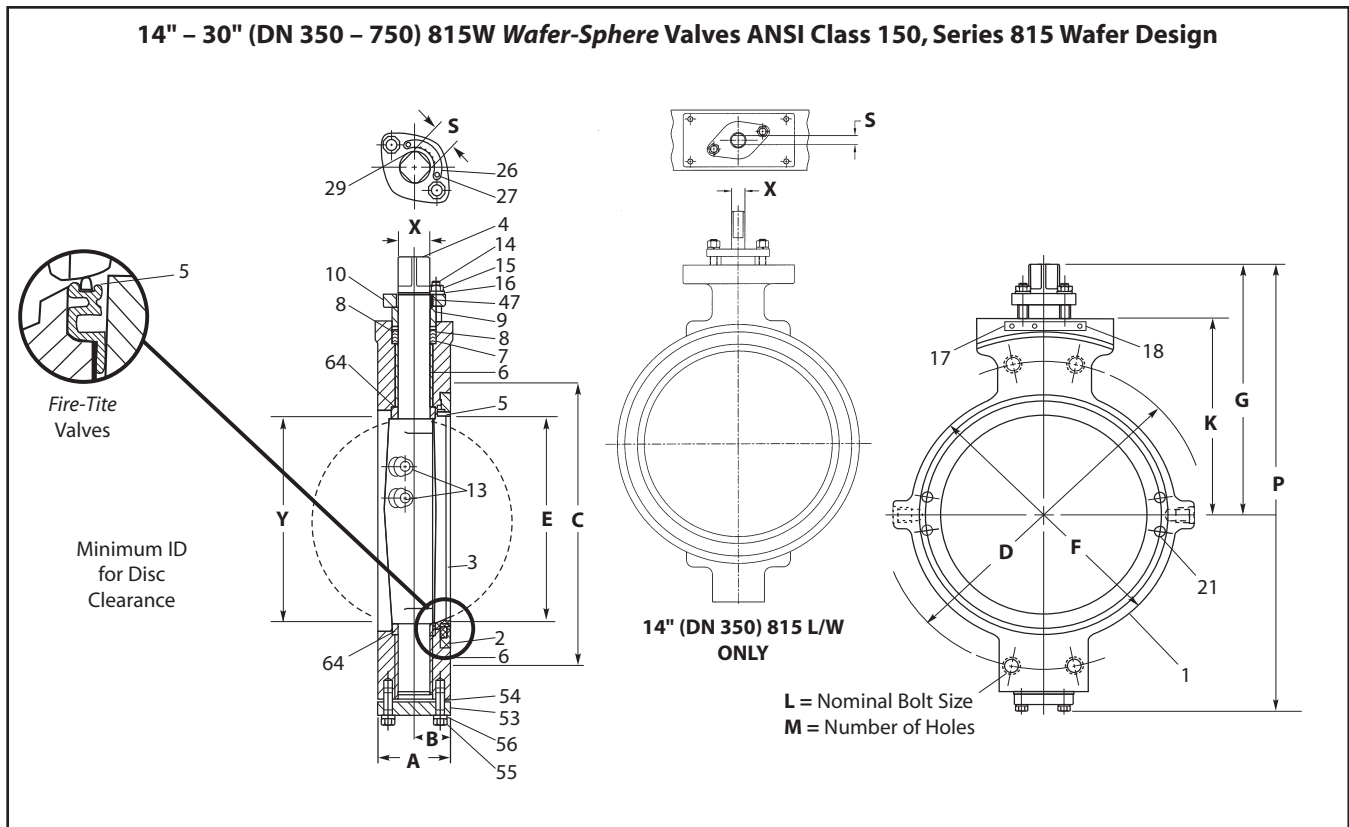

| Valve Size inches | Approximate Dimensions – inches | | | | | | | | | | | | | | Approx. Weight lbs. |
|-------------------|---------------------------------|------|-------|-------|-------|-------|-------|-------|----------|-----|-------|------|------|-------|---------------------|
| | A | B | C | D | E | F | G | K | L | M** | P | S | X | Y | |
| 14† | 3.63 | 2.06 | 16.25 | 18.75 | 12.38 | 16.25 | 15.53 | 12.16 | 1-1/8* | 0 | 27.75 | 1.13 | 1.63 | 12.50 | 181 |
| 16 | 4.00 | 2.22 | 18.50 | 21.25 | 14.28 | 18.50 | 16.56 | 13.06 | 1-1/16* | 4 | 29.22 | 1.63 | 1.88 | 14.38 | 253 |
| 18 | 4.50 | 2.63 | 21.00 | 22.75 | 16.28 | 21.00 | 17.66 | 14.03 | 1-3/16* | 4 | 31.56 | 1.63 | 2.13 | 16.38 | 345 |
| 20 | 5.00 | 2.63 | 23.00 | 25.00 | 17.94 | 23.00 | 18.38 | 14.88 | 1-1/8-8† | 4** | 33.13 | 1.63 | 2.38 | 17.88 | 438 |
| 24 | 6.06 | 3.00 | 27.25 | 29.50 | 21.63 | 27.25 | 23.91 | 19.28 | 1-1/4-8† | 4** | 45.69 | 2.00 | 2.75 | 21.34 | 735 |
| 30 | 6.56 | 3.44 | 33.75 | 36.00 | 27.63 | 33.75 | 27.44 | 22.44 | 1-1/4-8† | 4 | 51.44 | 2.00 | 3.50 | 28.00 | 1309 |

* Clearance instead of tapped holes
 ** Each side
 † ANSI B16.5 requires all bolts 1-1/8" (28.6 mm) and larger have an 8-UN thread series.
 ‡ 14" (DN 350) 815 L/W's have bladed shafts.

| Valve Size DN | Approximate Dimensions – mm | | | | | | | | | | | | | | Approx. Weight kg |
|---------------|-----------------------------|----|-----|-----|-----|-----|-----|-----|----------|-----|------|----|----|-----|-------------------|
| | A | B | C | D | E | F | G | K | L | M** | P | S | X | Y | |
| 350‡ | 92 | 52 | 413 | 476 | 314 | 413 | 394 | 309 | 1-1/8* | 0 | 705 | 29 | 41 | 318 | 82 |
| 400 | 102 | 56 | 470 | 540 | 363 | 470 | 421 | 332 | 1-1/16* | 4 | 742 | 41 | 48 | 365 | 115 |
| 450 | 114 | 67 | 533 | 578 | 414 | 533 | 449 | 356 | 1-3/16* | 4 | 802 | 41 | 54 | 416 | 156 |
| 500 | 127 | 67 | 584 | 635 | 456 | 584 | 467 | 378 | 1-1/8-8† | 4** | 842 | 41 | 60 | 454 | 199 |
| 600 | 154 | 76 | 692 | 749 | 549 | 692 | 607 | 490 | 1-1/4-8† | 4** | 1161 | 51 | 70 | 542 | 333 |
| 750 | 167 | 87 | 857 | 914 | 702 | 857 | 697 | 570 | 1-1/4-8† | 4 | 1307 | 51 | 89 | 711 | 594 |

* Clearance instead of tapped holes
 ** Each side
 † ANSI B16.5 requires all bolts 1-1/8" (28.6 mm) and larger have an 8-UN thread series.
 ‡ 14" (DN 350) 815 L/W's have bladed shafts.

DIMENSIONS (CONTINUED)

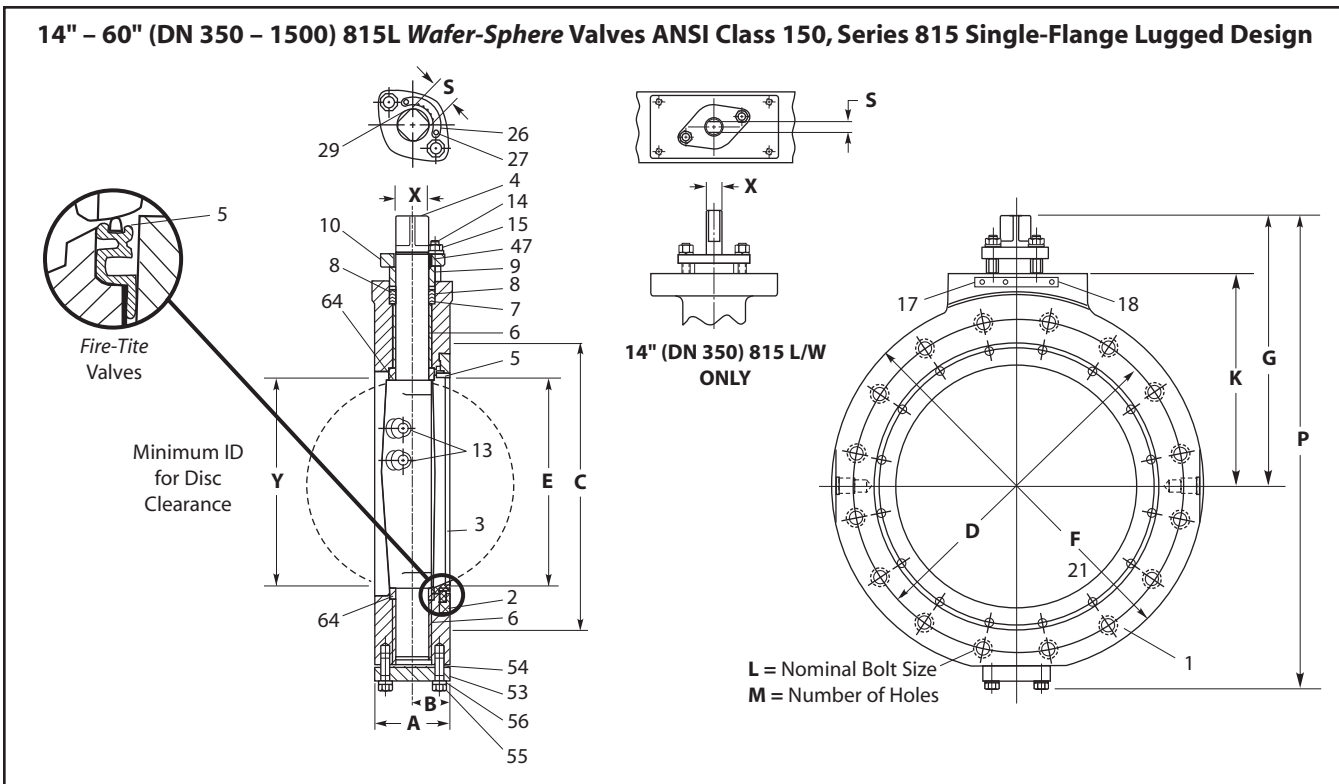

| Valve Size inches | Approximate Dimensions – inches | | | | | | | | | | | | | Approx. Weight lbs. | |
|-------------------|---------------------------------|------|-------|-------|-------|-------|-------|-------|----------------------|----|-------|-----------------------|------|---------------------|------|
| | A | B | C | D | E | F | G | K | L | M | P | S | X | | Y |
| 14 ³ | 3.63 | 2.06 | 16.25 | 18.75 | 12.38 | 21.00 | 15.53 | 12.16 | 1-8 | 12 | 27.75 | 1.13 | 1.63 | 12.50 | 231 |
| 16 | 4.00 | 2.22 | 18.50 | 21.25 | 14.28 | 23.50 | 16.56 | 13.06 | 1-8 | 16 | 29.22 | 1.63 | 1.88 | 14.38 | 360 |
| 18 | 4.50 | 2.63 | 21.00 | 22.75 | 16.28 | 25.00 | 17.66 | 14.03 | 1-1/8-8 ¹ | 16 | 31.56 | 1.63 | 2.13 | 16.38 | 453 |
| 20 | 5.00 | 2.63 | 23.00 | 25.00 | 17.94 | 27.50 | 18.38 | 14.88 | 1-1/8-8 ¹ | 20 | 33.13 | 1.63 | 2.38 | 17.88 | 596 |
| 24 | 6.06 | 3.00 | 27.25 | 29.50 | 21.63 | 32.00 | 23.91 | 19.28 | 1-1/4-8 ¹ | 20 | 45.69 | 2.00 | 2.75 | 21.34 | 964 |
| 30 | 6.56 | 3.44 | 33.75 | 36.00 | 27.63 | 38.75 | 27.44 | 22.44 | 1-1/4-8 ¹ | 28 | 51.44 | 2.00 | 3.50 | 28.00 | 1634 |
| 36 | 7.25 | 3.63 | 40.25 | 42.75 | 34.88 | 46.00 | 31.25 | 26.00 | 1-1/2-8 ¹ | 32 | 56.38 | 2.00 | 4.00 | 34.50 | 2621 |
| 42 | 8.75 | 4.50 | 47.00 | 49.50 | 40.00 | 53.00 | 40.25 | 29.00 | 1-1/2-8 ¹ | 36 | 68.13 | 4.00 Dia ² | 5.00 | 40.38 | 3800 |
| 48 | 10.00 | 5.13 | 53.50 | 56.00 | 46.00 | 59.50 | 44.50 | 33.25 | 1-1/2-8 ¹ | 44 | 76.88 | 5.00 Dia ² | 5.50 | 46.19 | 4800 |
| 54 | 10.50 | 5.25 | 59.50 | 62.75 | 52.31 | 66.38 | 49.13 | 37.50 | 1-3/4-8 ¹ | 44 | 85.75 | 6.00 Dia ² | 6.00 | 52.06 | 5800 |
| 60 | 11.00 | 5.75 | 66.00 | 69.25 | 57.94 | 73.00 | 54.75 | 41.13 | 1-3/4-8 ¹ | 52 | 95.38 | 6.00 Dia ² | 6.50 | 57.81 | 7000 |

| Valve Size DN | Approximate Dimensions – mm | | | | | | | | | | | | | Approx. Weight kg | |
|------------------|-----------------------------|-----|------|------|------|------|------|------|----------------------|----|------|----------------------|-----|-------------------|------|
| | A | B | C | D | E | F | G | K | L | M | P | S | X | | Y |
| 350 ³ | 92 | 52 | 413 | 476 | 314 | 533 | 394 | 309 | 1-8 | 12 | 705 | 24 | 41 | 318 | 105 |
| 400 | 102 | 56 | 470 | 540 | 363 | 597 | 421 | 332 | 1-8 | 16 | 742 | 41 | 48 | 365 | 163 |
| 450 | 114 | 67 | 533 | 578 | 414 | 635 | 449 | 356 | 1-1/8-8 ¹ | 16 | 802 | 41 | 54 | 416 | 205 |
| 500 | 127 | 67 | 584 | 635 | 456 | 699 | 467 | 378 | 1-1/8-8 ¹ | 20 | 842 | 41 | 60 | 454 | 270 |
| 600 | 154 | 76 | 692 | 749 | 549 | 813 | 607 | 490 | 1-1/4-8 ¹ | 20 | 1161 | 51 | 70 | 542 | 437 |
| 750 | 167 | 87 | 857 | 914 | 702 | 984 | 697 | 570 | 1-1/4-8 ¹ | 28 | 1307 | 51 | 89 | 711 | 741 |
| 900 | 184 | 92 | 1022 | 1086 | 886 | 1022 | 794 | 660 | 1-1/2-8 ¹ | 32 | 1432 | 51 | 102 | 876 | 1189 |
| 1050 | 222 | 114 | 1194 | 1257 | 1016 | 1346 | 1067 | 737 | 1-1/2-8 ¹ | 36 | 1731 | 102 Dia ² | 127 | 1026 | 1724 |
| 1200 | 254 | 130 | 1359 | 1422 | 1168 | 1511 | 1130 | 845 | 1-1/2-8 ¹ | 44 | 1953 | 127 Dia ² | 140 | 1173 | 2177 |
| 1350 | 267 | 133 | 1511 | 1594 | 1329 | 1686 | 1248 | 953 | 1-3/4-8 ¹ | 44 | 2178 | 152 Dia ² | 152 | 1322 | 2631 |
| 1500 | 279 | 146 | 1676 | 1759 | 1472 | 1854 | 1391 | 1045 | 1-3/4-8 ¹ | 52 | 2423 | 152 Dia ² | 165 | 1468 | 3175 |

1 ANSI B16.5 requires all bolts 1-1/8" (28.6 mm) and larger have 8-UN thread series.
 2 42" – 60" (DN 1050 – 1500) 815Ls have keyed shafts
 3 14" (DN 350) 815 L/W's have bladed shafts.

DIMENSIONS (CONTINUED)

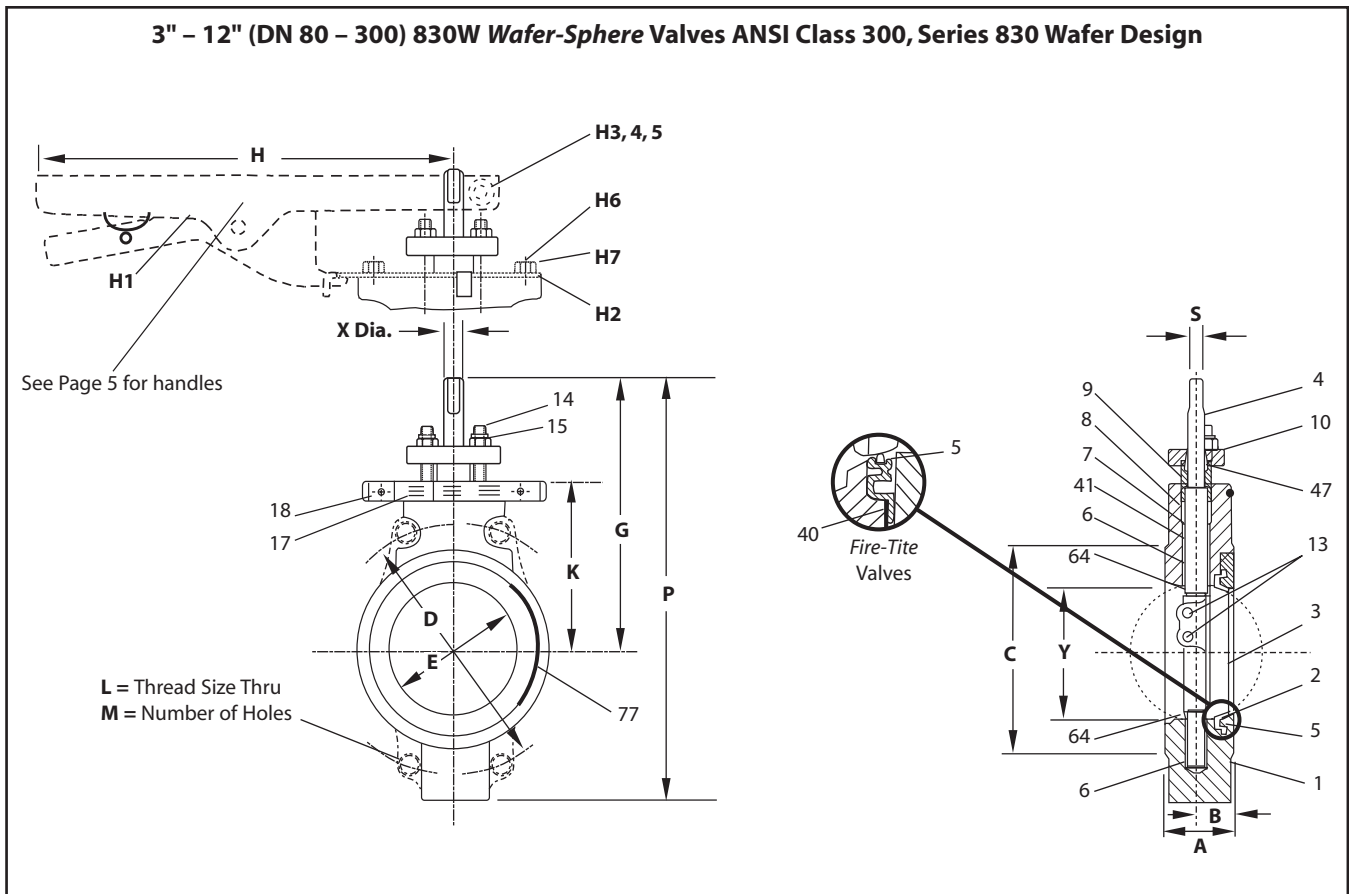

| Valve Size inches | Approximate Dimensions - inches | | | | | | | | | | | | | Approx. Weight lbs.** | |
|-------------------|---------------------------------|------|-------|-------|-------|-------|-------|-------|----------|---|-------|------|------|-----------------------|-----|
| | A | B | C | D | E | G | H | K | L | M | P | S | X | | Y* |
| 3 | 1.94 | 1.06 | 5.19 | — | 2.88 | 8.00 | 11.00 | 4.75 | — | — | 12.44 | 0.44 | 0.63 | 2.90 | 13 |
| 4 | 2.13 | 1.19 | 6.19 | — | 3.75 | 8.50 | 11.00 | 5.25 | — | — | 13.44 | 0.44 | 0.63 | 3.83 | 18 |
| 6 | 2.31 | 1.34 | 8.50 | — | 5.59 | 10.13 | 22.00 | 6.88 | — | — | 16.25 | 0.63 | 0.88 | 5.76 | 32 |
| 8 | 2.88 | 1.56 | 10.63 | — | 7.41 | 12.06 | 22.00 | 8.38 | — | — | 19.50 | 0.81 | 1.13 | 7.63 | 60 |
| 10 | 3.25 | 1.75 | 12.75 | 15.25 | 9.28 | 13.88 | 22.00 | 10.00 | 1-8 | 4 | 23.31 | 0.94 | 1.38 | 9.56 | 106 |
| 12 | 3.63 | 1.97 | 15.00 | 17.75 | 11.09 | 15.31 | — | 11.13 | 1-1/8-8† | 4 | 26.56 | 1.13 | 1.63 | 11.37 | 145 |

* Conforms to API 609 and MSS-SP 68 requirements for minimum clearances of pipe inside diameters for Schedule 80 pipe.

** Weights do not include handles. See page 5 for handle weights

† ANSI B16.5 requires all bolts 1-1/8" (28.6 mm) and larger have 8-UN thread series.

| Valve Size DN | Approximate Dimensions - mm | | | | | | | | | | | | | Approx. Weight kg** | |
|---------------|-----------------------------|----|-----|-----|-----|-----|-----|-----|----------|---|-----|----|----|---------------------|----|
| | A | B | C | D | E | G | H | K | L | M | P | S | X | | Y* |
| 80 | 49 | 27 | 132 | — | 73 | 203 | 279 | 121 | — | — | 316 | 11 | 16 | 74 | 6 |
| 100 | 54 | 30 | 157 | — | 95 | 216 | 279 | 133 | — | — | 341 | 11 | 16 | 97 | 8 |
| 150 | 59 | 34 | 216 | — | 142 | 257 | 559 | 175 | — | — | 413 | 16 | 22 | 146 | 15 |
| 200 | 73 | 40 | 270 | — | 188 | 306 | 559 | 213 | — | — | 495 | 21 | 29 | 194 | 27 |
| 250 | 83 | 44 | 324 | 387 | 236 | 353 | 559 | 254 | 1-8 | 4 | 592 | 24 | 35 | 243 | 48 |
| 300 | 92 | 50 | 381 | 451 | 282 | 389 | — | 283 | 1-1/8-8† | 4 | 675 | 29 | 41 | 289 | 66 |

* Conforms to API 609 and MSS-SP 68 requirements for minimum clearances of pipe inside diameters for Schedule 80 pipe.

** Weights do not include handles. See page 5 for handle weights

† ANSI B16.5 requires all bolts 1-1/8" (28.6 mm) and larger have 8-UN thread series.

DIMENSIONS (CONTINUED)

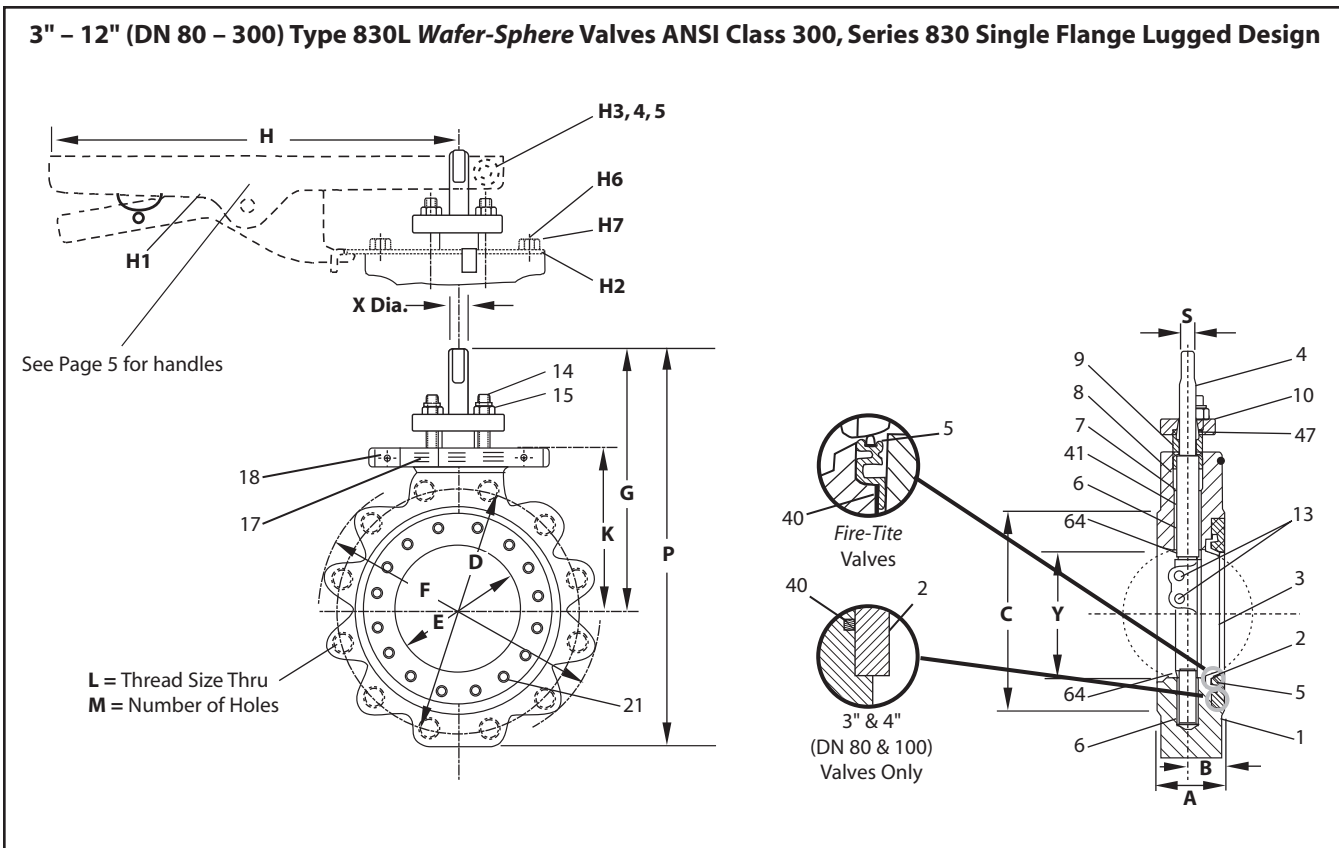

| Valve Size inches | Approximate Dimensions - inches | | | | | | | | | | | | | | | Approx. Weight lbs.** |
|-------------------|---------------------------------|------|-------|-------|-------|-------|-------|-------|-------|----------|----|-------|------|------|-------|-----------------------|
| | A | B | C | D | E | F | G | H | K | L | M | P | S | X | Y* | |
| 2-1/2 | 1.94 | 1.06 | 4.13 | 5.88 | 2.38 | 7.50 | 7.63 | 11.00 | 4.38 | 3/4-10 | 8 | 11.19 | 0.44 | 0.63 | 1.88 | 16 |
| 3 | 1.94 | 1.06 | 5.19 | 6.63 | 2.88 | 8.13 | 8.00 | 11.00 | 4.75 | 3/4-10 | 8 | 12.44 | 0.44 | 0.63 | 2.90 | 20 |
| 4 | 2.13 | 1.19 | 6.19 | 7.88 | 3.75 | 9.38 | 8.50 | 11.00 | 5.25 | 3/4-10 | 8 | 13.44 | 0.44 | 0.63 | 3.83 | 29 |
| 5 | 2.50 | 1.31 | 7.31 | 9.25 | 4.38 | 10.97 | 9.25 | 11.00 | 6.03 | 3/4-10 | 8 | 14.25 | 0.53 | 0.75 | 4.38 | 41 |
| 6 | 2.31 | 1.34 | 8.50 | 10.63 | 5.59 | 12.13 | 10.13 | 22.00 | 6.88 | 3/4-10 | 12 | 16.25 | 0.63 | 0.88 | 5.76 | 52 |
| 8 | 2.88 | 1.56 | 10.63 | 13.00 | 7.41 | 15.00 | 12.06 | 22.00 | 8.38 | 7/8-9 | 12 | 19.50 | 0.81 | 1.13 | 7.63 | 92 |
| 10 | 3.25 | 1.75 | 12.75 | 15.25 | 9.28 | 17.50 | 13.88 | 22.00 | 10.00 | 1-8 | 16 | 23.31 | 0.94 | 1.38 | 9.56 | 160 |
| 12 | 3.63 | 1.97 | 15.00 | 17.75 | 11.09 | 20.25 | 15.31 | — | 11.13 | 1-1/8-8† | 16 | 26.56 | 1.13 | 1.63 | 11.37 | 220 |

* Conforms to API 609 and MSS-SP 68 requirements for minimum clearances of pipe inside diameters for Schedule 80 pipe

** Weights do not include handles. See page 5 for handle weights

† ANSI B16.5 requires all bolts 1-1/8" (28.6 mm) and larger have 8-UN thread series.

| Valve Size DN | Approximate Dimensions - mm | | | | | | | | | | | | | | | Approx. Weight kg ** |
|---------------|-----------------------------|----|-----|-----|-----|-----|-----|-----|-----|----------|----|-----|----|----|-----|----------------------|
| | A | B | C | D | E | F | G | H | K | L | M | P | S | X | Y* | |
| 65 | 49 | 27 | 105 | 149 | 60 | 191 | 194 | 279 | 111 | 3/4-10 | 8 | 284 | 11 | 16 | 48 | 7 |
| 80 | 49 | 27 | 132 | 168 | 73 | 207 | 203 | 279 | 121 | 3/4-10 | 8 | 316 | 11 | 16 | 74 | 9 |
| 100 | 54 | 30 | 157 | 200 | 95 | 238 | 216 | 279 | 133 | 3/4-10 | 8 | 341 | 11 | 16 | 97 | 13 |
| 125 | 64 | 33 | 186 | 235 | 111 | 279 | 235 | 279 | 153 | 3/4-10 | 8 | 362 | 13 | 19 | 111 | 19 |
| 150 | 59 | 34 | 216 | 270 | 142 | 308 | 257 | 559 | 175 | 3/4-10 | 12 | 413 | 16 | 22 | 146 | 24 |
| 200 | 73 | 40 | 270 | 330 | 188 | 381 | 306 | 559 | 213 | 7/8-9 | 12 | 495 | 21 | 29 | 194 | 42 |
| 250 | 83 | 44 | 324 | 387 | 236 | 445 | 353 | 559 | 254 | 1-8 | 16 | 592 | 24 | 35 | 243 | 73 |
| 300 | 92 | 50 | 381 | 451 | 282 | 514 | 389 | — | 283 | 1-1/8-8† | 16 | 675 | 29 | 41 | 289 | 100 |

* Conforms to API 609 and MSS-SP 68 requirements for minimum clearances of pipe inside diameters for Schedule 80 pipe

** Weights do not include handles. See page 5 for handle weights

† ANSI B16.5 requires all bolts 1-1/8" (28.6 mm) and larger have 8-UN thread series.

DIMENSIONS (CONTINUED)

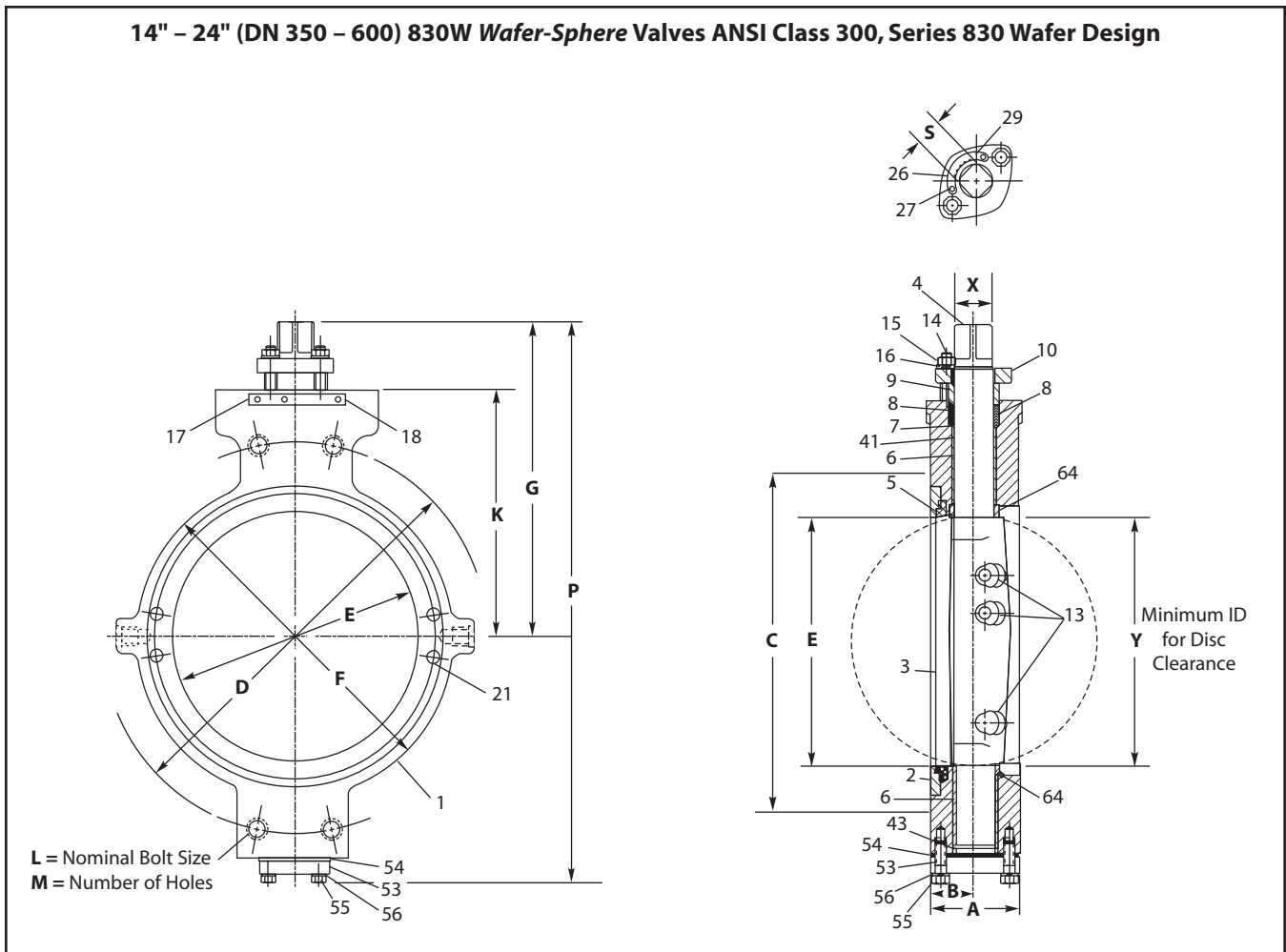

| Valve Size inches | Approximate Dimensions – inches | | | | | | | | | | | | | | Approx. Weight lbs. |
|-------------------|---------------------------------|------|-------|-------|-------|-------|-------|-------|----------------------|---|-------|------|------|-------|---------------------|
| | A | B | C | D | E | F | G | K | L | M | P | S | X | Y | |
| 14 | 4.63 | 2.31 | 16.25 | 20.25 | 12.38 | 16.25 | 16.43 | 12.80 | 1-1/8-8 [†] | 4 | 28.75 | 1.63 | 2.13 | 11.75 | 368 |
| 16 | 5.25 | 2.44 | 18.50 | 22.50 | 14.31 | 18.50 | 17.31 | 13.80 | 1-1/4-8 [†] | 4 | 30.75 | 1.63 | 2.13 | 13.63 | 429 |
| 18 | 5.88 | 2.94 | 21.00 | 24.75 | 16.28 | 21.00 | 21.34 | 16.71 | 1-1/4-8 [†] | 4 | 37.80 | 2.00 | 2.75 | 15.44 | 715 |
| 20 | 6.38 | 3.19 | 23.00 | 27.00 | 17.91 | 23.00 | 22.58 | 17.58 | 1-1/4-8 [†] | 4 | 39.95 | 2.00 | 3.50 | 17.06 | 896 |
| 24 | 7.25 | 3.63 | 27.25 | 32.00 | 21.63 | 27.25 | 24.96 | 19.71 | 1-1/2-8 [†] | 4 | 44.93 | 2.00 | 4.00 | 20.63 | 1,390 |

[†] ANSI B16.5 requires all bolts 1-1/8" (28.6 mm) and larger have 8-UN thread series.

| Valve Size DN | Approximate Dimensions – mm | | | | | | | | | | | | | | Approx. Weight kg |
|---------------|-----------------------------|----|-----|-----|-----|-----|-----|-----|----------------------|---|------|----|-----|-----|-------------------|
| | A | B | C | D | E | F | G | K | L | M | P | S | X | Y | |
| 350 | 118 | 59 | 413 | 514 | 314 | 413 | 417 | 325 | 1-1/8-8 [†] | 4 | 730 | 41 | 54 | 298 | 167 |
| 400 | 133 | 62 | 470 | 572 | 363 | 470 | 440 | 351 | 1-1/4-8 [†] | 4 | 781 | 41 | 54 | 346 | 195 |
| 450 | 149 | 75 | 533 | 629 | 414 | 533 | 542 | 424 | 1-1/4-8 [†] | 4 | 960 | 51 | 70 | 392 | 324 |
| 500 | 162 | 81 | 584 | 686 | 455 | 584 | 574 | 447 | 1-1/4-8 [†] | 4 | 1015 | 51 | 89 | 433 | 406 |
| 600 | 184 | 92 | 692 | 813 | 549 | 692 | 634 | 501 | 1-1/2-8 [†] | 4 | 1141 | 51 | 102 | 524 | 631 |

[†] ANSI B16.5 requires all bolts 1-1/8" (28.6 mm) and larger have 8-UN thread series.

DIMENSIONS (CONTINUED)

14" – 36" (DN 350 – 900) 830L Wafer-Sphere Valves ANSI Class 300, Series 830 Single Flange Lugged Design

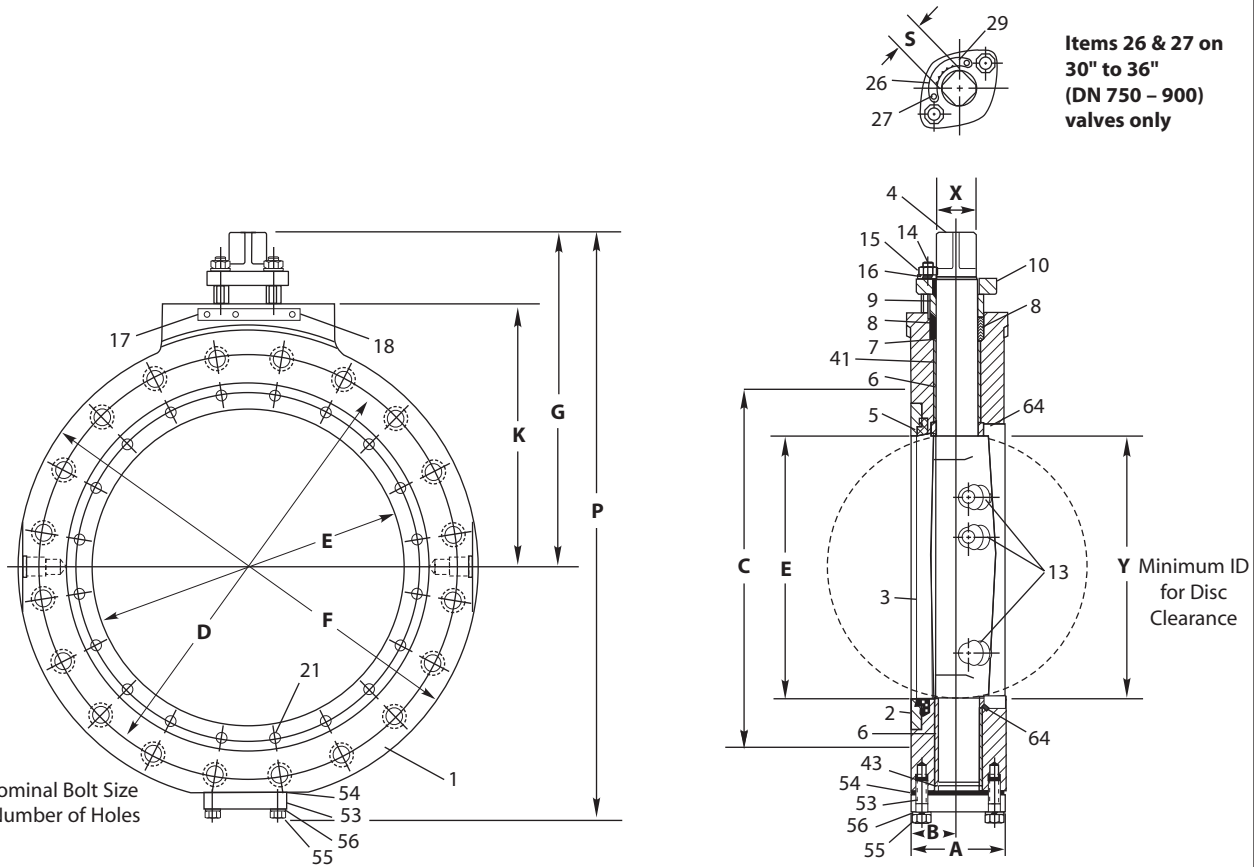

| Valve Size inches | Approximate Dimensions – inches | | | | | | | | | | | | | | Approx. Weight lbs. |
|-------------------|---------------------------------|------|-------|-------|-------|-------|-------|-------|----------------------|----|-------|------------|------|-------|---------------------|
| | A | B | C | D | E | F | G | K | L | M | P | S | X | Y | |
| 14 | 4.63 | 2.31 | 16.25 | 20.25 | 12.38 | 23.00 | 16.43 | 12.80 | 1-1/8-8 [†] | 20 | 28.75 | 1.63 | 2.13 | 11.75 | 557 |
| 16 | 5.25 | 2.44 | 18.50 | 22.50 | 14.31 | 25.50 | 17.31 | 13.80 | 1-1/4-8 [†] | 20 | 30.75 | 1.63 | 2.13 | 13.63 | 724 |
| 18 | 5.88 | 2.94 | 21.00 | 24.75 | 16.28 | 28.00 | 21.34 | 16.71 | 1-1/4-8 [†] | 24 | 37.80 | 2.00 | 2.75 | 15.44 | 1,110 |
| 20 | 6.38 | 3.19 | 23.00 | 27.00 | 17.91 | 30.50 | 22.58 | 17.58 | 1-1/4-8 [†] | 24 | 39.95 | 2.00 | 3.50 | 17.06 | 1,428 |
| 24 | 7.25 | 3.63 | 27.25 | 32.00 | 21.63 | 36.00 | 24.96 | 19.71 | 1-1/2-8 [†] | 24 | 44.93 | 2.00 | 4.00 | 20.63 | 2,170 |
| 30 | 10.75 | 5.38 | 33.75 | 39.25 | 27.69 | 43.00 | 36.31 | 25.28 | 1-3/4-8 [†] | 28 | 61.00 | 3.50 Dia.* | 5.50 | 28.75 | 2,800 |
| 36 | 11.25 | 5.63 | 40.25 | 46.00 | 34.88 | 50.00 | 41.44 | 30.81 | 2-8 [†] | 32 | 71.80 | 4.00 Dia.* | 6.00 | 35.00 | 3,400 |

[†] ANSI B16.5 requires all bolts 1-1/8" (28.6 mm) and larger have 8-UN thread series.

* 30" and 36" (DN 50 – 900) 830Ls have keyed shaft.

| Valve Size DN | Approximate Dimensions – mm | | | | | | | | | | | | | | Approx. Weight kg |
|---------------|-----------------------------|-----|------|------|-----|------|------|-----|----------------------|----|------|-----------|-----|-----|-------------------|
| | A | B | C | D | E | F | G | K | L | M | P | S | X | Y | |
| 350 | 118 | 59 | 413 | 514 | 314 | 584 | 417 | 325 | 1-1/8-8 [†] | 20 | 730 | 41 | 54 | 298 | 253 |
| 400 | 133 | 62 | 470 | 572 | 363 | 648 | 440 | 351 | 1-1/4-8 [†] | 20 | 781 | 41 | 54 | 346 | 328 |
| 450 | 149 | 75 | 533 | 629 | 414 | 711 | 542 | 424 | 1-1/4-8 [†] | 24 | 960 | 51 | 70 | 392 | 503 |
| 500 | 162 | 81 | 584 | 686 | 455 | 775 | 574 | 447 | 1-1/4-8 [†] | 24 | 1015 | 51 | 89 | 433 | 648 |
| 600 | 184 | 92 | 692 | 813 | 549 | 914 | 634 | 501 | 1-1/2-8 [†] | 24 | 1141 | 51 | 102 | 524 | 984 |
| 750 | 273 | 137 | 857 | 997 | 703 | 1092 | 922 | 642 | 1-3/4-8 [†] | 28 | 1549 | 89 Dia.* | 140 | 730 | 1270 |
| 900 | 286 | 143 | 1022 | 1168 | 886 | 1270 | 1053 | 783 | 2-8 [†] | 32 | 1824 | 102 Dia.* | 152 | 889 | 1542 |

[†] ANSI B16.5 requires all bolts 1-1/8" (28.6 mm) and larger have 8-UN thread series.

* 30" and 36" (DN 50 – 900) 830Ls have keyed shaft.

HOW TO ORDER SERIES 815 AND 830 WAFER-SPHERE VALVES

As the use of the valve is application specific, a number of factors should be taken into account when selecting a valve for a given application. Therefore, some of the situations in which the valves are used are outside the scope of this manual. If you have any questions concerning the use, application or compatibility of the valve with the intended service, contact Metso for more information.

These *Wafer-Sphere* valves are described by size and alpha-numeric code that defines body configuration, body, disc, shaft, seat, seal materials, and with options to denote special service and modifiers. Explanation of the code for valves in this bulletin is as follows:

EXAMPLE: The figure designation for a 6" ASME/ANSI Class 150 single-flange lug-design valve, with double packing, monitoring port, carbon steel body, Monel disc and shaft, filled *Xtreme* seat, Carbon-filled enhanced PTFE shaft seal, and live-loaded shaft seals, is: **6" 815L DL-11-2271XZ-QY**.

| 1 | 2 | 3 | 4 | 5 | 6 | 7 | 8 | 9 |
|----|-----|---|----|----|----|----|----|----|
| 6" | 815 | L | DL | 11 | 22 | 71 | XZ | QY |

| 1 | Size |
|--------------------------------|--------------------------------------|
| 2-1/2" – 60" (DN 65 – 1500) | See page 1 for specific availability |

| 2 | Pressure Class |
|------|--|
| 815 | Standard ANSI Class 150 |
| F815 | <i>Fire-Tite</i> ANSI Class 150 |
| 818 | Standard ANSI Class 150 w/CE Marking and Documentation |
| F818 | <i>Fire-Tite</i> ANSI Class 150 w/CE Marking and Documentation |
| 830 | Standard ANSI Class 300 |
| F830 | <i>Fire-Tite</i> ANSI Class 300 |
| 838 | Standard ANSI Class 300 w/CE Marking and Documentation |
| F838 | <i>Fire-Tite</i> ANSI Class 300 w/CE Marking and Documentation |

| 3 | Body Style |
|---|----------------------|
| W | Wafer |
| L | Single-flange lugged |

| 4 | Special Service |
|-----|-------------------------------------|
| C | Chlorine |
| O | Oxygen |
| H | Hard-coated disc |
| HV | High vacuum |
| HVC | High vacuum certified |
| D | Double packing |
| DL | Double packing with monitoring port |

| 5 | Seat Type |
|----|----------------------------------|
| 11 | Standard (non <i>Fire-Tite</i>) |
| 31 | Standard (<i>Fire-Tite</i>) |

| 6 | Body Material |
|-----------------|---------------------|
| 22 ¹ | Carbon steel |
| 35 | Alloy 20 |
| 36 ¹ | 316 Stainless steel |
| 37 ¹ | 317 Stainless steel |
| 71 ¹ | Monel |
| 73 | Hastelloy C |

| 7 | Disc & Shaft Material |
|-------------------|---|
| 00 ^{2,4} | Same as body material |
| HB ¹ | 316 Stainless steel disc, 17-4 PH shaft |
| 35 | Alloy 20 disc and shaft |
| 36 | 316 Stainless steel disc and shaft |
| 37 | 317 Stainless steel |
| 71 ¹ | Monel disc and shaft |
| 73 | Hastelloy C disc and shaft |

| 8 | Seat & Seal Material |
|------------------|---|
| Standard | |
| TT | PTFE seat and seal |
| MT ⁵ | Filled PTFE seat, PTFE seal |
| UU | UHMW polyethylene seat and seal |
| XZ | <i>Xtreme</i> seat & carbon-filled enhanced PTFE seal |
| Fire-Tite | |
| AE | PTFE/Stainless steel seat, graphite seal |
| AF | PTFE/Alloy 20 seat, graphite seal |
| AH | PTFE/Monel seat, graphite seal |
| XE | <i>Xtreme</i> /Stainless steel seat, graphite seal |
| XF | <i>Xtreme</i> /Alloy 20 seat, graphite seal |
| XH | <i>Xtreme</i> /Monel seat, graphite seal |

| 9 | Modifier Code |
|-----------------|--|
| — | Standard |
| QY | Live-loaded packing |
| MM ³ | Composite shaft bearings, Filled PEEK thrust bearings and excluder rings (High Cycle Construction) |
| | For other, please describe. Factory will supply code. |

Hastelloy is a registered trademark of Haynes International, Inc
Monel is a registered trademark of INCO Alloys International, Inc.

- Material meets NACE MR0103 requirements for sour environments. For valves to be in full compliance with NACE MR0103, both the body (sign #6) and trim (sign #7) must meet the NACE MR0103 requirement.
- Valves with the Disc & Shaft Material Code "00" (sign #7) meet the NACE MR0103 requirement for sour environments if the body code (sign #6) is 71.
- Modifier code MM requires seat & seal material XZ.
- Not available with 22 body material.
- Non-standard seat offering replaced by *Xtreme* Seat (XZ) offering. Consult factory regarding other materials of construction that are not listed.

STANDARDS AND SPECIFICATIONS

Series 815 & 830 valves covered in this bulletin are available to conform to the following industry standards and specifications.

The Company

ISO 9001 – 2000 ANSI/150/ASQ Q9001 – 2000
Pressure Equipment Directive 97/23/EC

The Product - Standard

| | |
|--------------------|---|
| API 607 | American Petroleum Institute - Fire Test for Soft Seated Valves (Division of refining) |
| BS 6755 | British Standard Testing of valves Part 2. Specification for fire type-testing requirements |
| ASME B16.10 | American National Standard - Face-to-Face and End-to-End Dimensions of Ferrous Valves 3" – 24" only, 2-1/2" and 5" and not defined in ASME B16.10 |
| ASME B16.5 | American National Standard - Steel Pipe Flanges and Flanged Fittings 3" – 24" only |
| ASME B16.47 | American National Standard - Large Diameter Steel Flanges NPS 26 through NPS 60 |
| ASME B16.34 | American National Standard - Steel Valves - Flanged and Buttwelded End |
| ASME B31.1 | American National Standard - Power Piping |
| ASME B31.3 | American National Standard - Chemical Plant and Petroleum Refinery Piping |
| ASME B31.4 | American National Standard - Liquid Transportation Systems for Hydrocarbons (Liquid Petroleum Gas), Anhydrous Ammonia, and Alcohols |
| ASME B31.8 | American National Standard - Gas Transmission and Distribution Piping Systems |
| ANSI/FCI 70-2-1991 | American National Standard - For Control Valve Seat Leakage |
| ISA 75.02 | Valve Sizing Coefficient C_v , Piping Geometry Factor F_p and Pressure Drop Limitation XT |
| MSS SP-25 | Manufacturers Standardization Society - Standard Marking System for Valves |
| MSS-SP-44 | Steel Pipe Line Flanges |
| MSS-SP-55 | Manufacturers Standardization Society - Quality Standards for Steel Castings |
| MSS-SP-61 | Pressure Testing of Steel Valves |
| MSS SP-96 | Terminology for Valves and Fittings |

The Product - Optional

| | |
|--------------|---|
| API 598 | American Petroleum Institute - Valve Inspection and Testing |
| API 609 | American Petroleum Institute - Butterfly Valves: Double Flanged, Lug- and Wafer-Type 3" – 24" only, 2-1/2" and 5" and not defined in API 609. Requires API 598 testing. |
| MSS SP-68 | Manufacturers Standardization Society - High Pressure Butterfly Valves with Offset Design. Requires API 598 testing. |
| 97 / 23 / EC | Pressure Equipment Directive - See "How to Order" Section |
| MSS SP-53 | Quality Standard For Steel Castings and Forgings for Valves, Flanges and Fittings and Other Piping Components - Magnetic Particle Examination Method |
| MSS SP-54 | Quality Standard For Steel Castings for Valves, Flanges and Fittings and Other Piping Components - Radiographic Examination Method |
| MSS SP-93 | Quality Standard For Steel Castings and Forgings for Valves, Flanges and Fittings and Other Piping Components - Liquid Penetrant Method |
| NACE | Standard MR0103 National Association of Corrosion Engineers - Engineers - Materials Resistant to Sulfide Stress Cracking in Corrosive Petroleum Refining Environments |