

Fisher® EW Series (EWD/EWS/EWT) Sliding-Stem Control Valves through NPS 12x8

Fisher® EW Series easy-e® valves (figures 1, 2, 3, 4, and 5) feature large internal cavities with expanded end connections and a variety of unbalanced and balanced plug designs. Sizes available from NPS 4x2⁽¹⁾ through 12x8. These combinations provide good fluid control in economical, high-capacity valve bodies that keep valve outlet velocities within practical limits.

These valves meet a variety of service requirements, such as power plants where oversized piping is used to limit fluid flow velocity. They also perform well in noise abatement applications; for example, high-pressure gas reducing stations where sonic velocities are often encountered at the outlet of conventional valve bodies.

The Fisher EW product line is available for a wide range of applications, including sulfide and chloride stress-cracking environments common to the oil and gas production industries. To discuss available constructions, contact your Emerson Process Management sales office and include the applicable codes and standards required for these environments.

The easy-e® Valve Family

EW Series valves are part of the versatile easy-e family of Fisher industrial control valves. easy-e valves share the following characteristics:

- Multiple trim material choices
- Trim temperature capability with metal seats standard to 427°C (800°F)
- Interchangeable, restricted-capacity trims and full-size trims to match variable process flow demands

1. Valve body size: end connection size by nominal trim size. For example, an NPS 4x2 EWD valve has NPS 4 end connections with nominal 2-inch trim.



Figure 1. Fisher® NPS 12x6 EWT or EWD Valve with 667 Actuator

- Different cage/plug styles that provide particular flow characteristics for highly-specialized applications. The standard cage comes in three different flow characteristics:
 - quick-opening
 - linear
 - equal percentage
- Cavitrol® III cages are available to eliminate cavitation damage and Whisper Trim® III cages are available to help attenuate aerodynamic noise.
- 316 stainless steel packing box parts are standard (including packing flange, studs, and nuts)



EW Valve

Contents

Features	2
C-seal™ Trim Description	3
ENVIRO-SEAL and HIGH-SEAL Packing Systems	4
Available Configurations	8
Material Selection Guidelines	8
ANSI/FCI Class VI Shutoff Capabilities	10
Fisher TSO (Tight Shutoff) Trim Capabilities	11
Installation	11
Tables	
Metal Trim Part Materials for Compatibility with NACE MR0175-2002 (Sour Service) Specifications, Environmental Restrictions Apply, Refer to Standard	7
Available Valve Constructions	8
Shutoff Classifications	9
C-seal Shutoff Classification	9
Metal Trim Part Combinations	10
Class VI Shutoff Availability	10
Class VI Trim Materials	10
TSO Leakage Class	11
TSO Shutoff Availability	11
Port Diameters, Valve Plug Travel, Yoke Boss Diameters for TSO Trim	11
Valve Trim Temperature Capabilities ...	13
CL900 Metal Trim Part Combinations ...	15
Cavitrol Metal Trim Part Combination ...	16
Cavitrol Temperature Capabilities	16
Metal Trim Part Combinations (Whisper)	18
Valve Trim Temperature Capabilities Whisper Trim	19
Metal Trim Part Combinations (Whisper)	20
Materials and Temperature Limitations for Other Parts	22
Additional Specifications	23
Approximate Weights	25
Bonnet Selection Guidelines	26
Bolting Materials and Temperature Limits with NACE MR0175-2002	26
Dimensions	27
Coefficients	29
Specifications	42

The temperature limits of EWT valves can be extended above 232°C (450°F) by using PEEK (PolyEtherEtherKetone) anti-extrusion rings in combination with a spring-loaded PTFE seal. The PEEK anti-extrusion rings expand to close off the clearance gap between the plug and the cage where the PTFE seal may extrude at high temperatures and pressures. The temperature limits are extended to 316°C (600°F) for non-oxidizing service and to 260°C (500°F) for oxidizing service.

Note

Refer to Fisher bulletin 51.2:EWN for information on EWN Series valves with Whisper Trim III cages.

Note

Refer to Fisher bulletin 80.3:010 for information on WhisperFlo® Aerodynamic Noise Attenuation Trim.

Features

- **Compliance with the Clean Air Act**—Patented ENVIRO-SEAL® packing systems provide an improved stem seal to help prevent the loss of valuable or hazardous process fluid. The ENVIRO-SEAL packing systems feature PTFE or Graphite ULF packing with live-loading for reduced packing maintenance.

● **Noise Attenuation**—In an EW Series valve, noise produced by high flow rates and large pressure drops can be reduced by up to 18 dbA with a Whisper Trim I cage and by up to 30 dbA with a Whisper Trim III cage.

● **Piping Economy**—Expanded end connections of EW Series valve bodies may reduce the need for line swages while accommodating oversized piping arrangements used to limit fluid flow velocities.

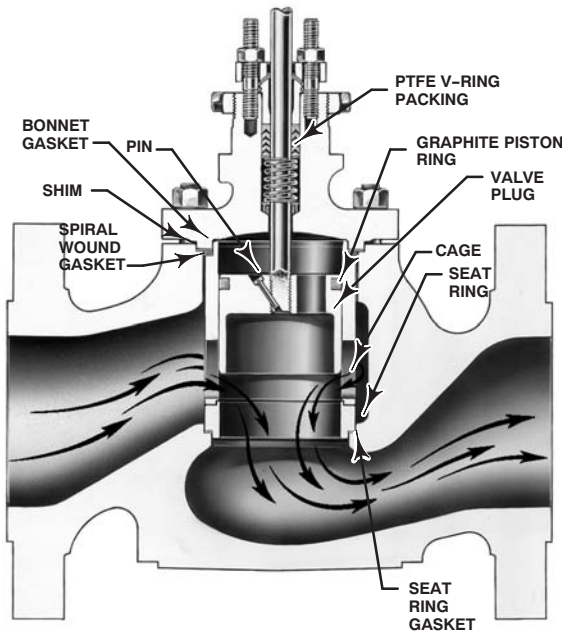

W9035

TYPICAL OF CONSTRUCTIONS THROUGH NPS 12x6

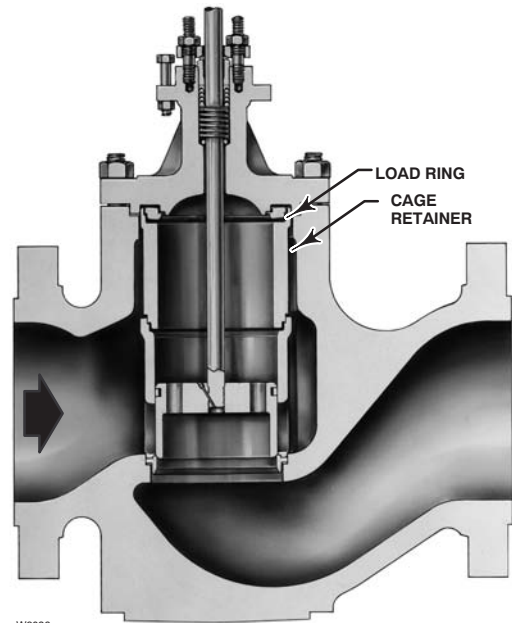

W9036

NPS 12x8 CONSTRUCTION

NOTE:
THE NPS 10x8 VALVE IS SIMILAR IN APPEARANCE TO SIZES THROUGH NPS 12x6.
HOWEVER, THE NPS 10x8 USES THE LOAD RING SHOWN FOR THE NPS 12x8.
IT DOES NOT USE THE CAGE RETAINER.

Figure 2. Fisher® EWD Valve with Standard Cage

- **Temperature Compensation**—On designs with the seat ring threaded into the valve body (figure 5), the hung cage feature helps reduce gasketing problems caused by thermal expansion and contraction of long parts, such as the cage assembly.

- **Standard Trim Parts across the easy-e product line**—Included are FGM gaskets, packing flange, studs, and nuts.

- **High-Temperature, Class IV or Class V Shutoff**—Optional multiple piston rings (figure 15) for EWD and EWD-1 valve bodies permit Class IV shutoff up to 593°C (1100°F). Use of C-seal trim (see figure 6) permits Class V shutoff up to 593°C (1100°F).

- **Increased Pressure/Temperature Ratings**—NPS 12x8 CL900 EW Series valve bodies with buttwelding end connections are capable of increased ASME ratings called Intermediate Standard Ratings. The extra strength of the valve body allows these valves to be used where pressures and temperatures exceed Standard Class

ratings in ASME B16.34.

See Bulletin 59.1:027, Increased Pressure/ Temperature Ratings for EW Series Steel Valve Bodies, for further information.

- **Sour Service Capability**— Unless otherwise noted, references are to NACE MR0175-2002. Optional materials are available to meet NACE MR0103 and NACE MR0175 / ISO 15156. Material requirements under these standards vary by edition and year of issue; the specific standard must be specified.

C-seal Trim Description

C-seal trim (figure 6) is available for valves with port diameters from 2.875 inches through 8 inches.

With C-seal trim, a balanced valve can achieve high-temperature, Class V shutoff. Because the C-seal plug seal is formed from metal (N07718 nickel alloy) rather than an elastomer, a valve equipped with the C-seal trim can be applied in processes with a fluid temperature of up to 593°C (1100°F).

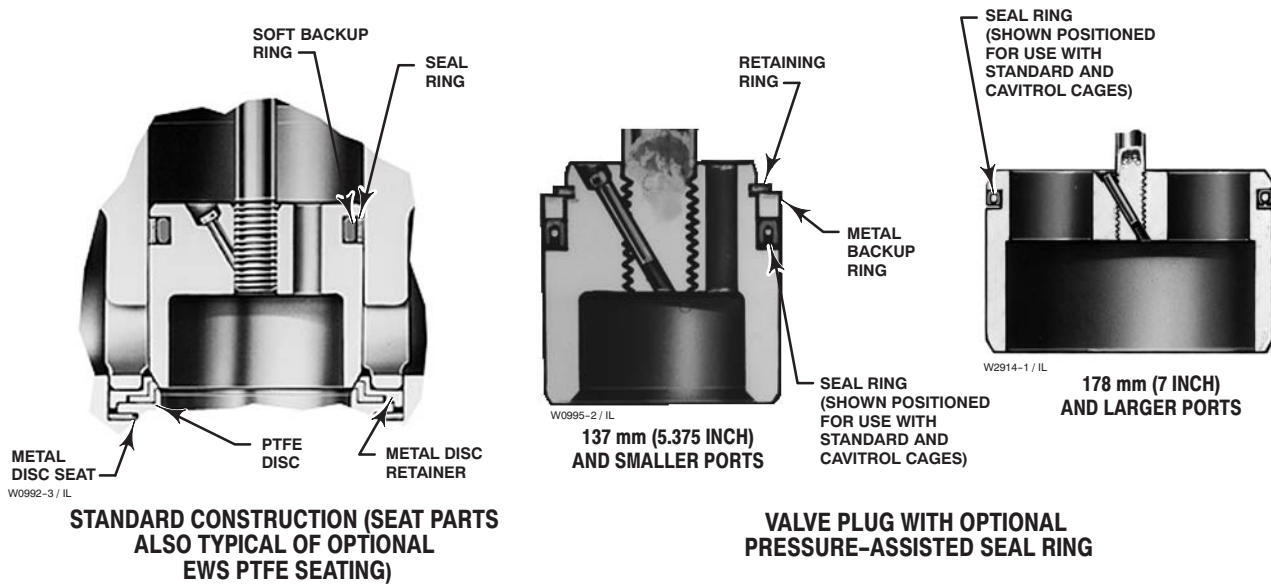

Figure 3. Fisher® EWT Trim Details

ENVIRO-SEAL and HIGH-SEAL Packing Systems

Fisher ENVIRO-SEAL and HIGH-SEAL packing systems (figure 19) offer excellent sealing capabilities. These systems easily install in your existing valves or can be purchased with new valves. These systems help you seal your process to conserve valuable process fluid and to protect the environment against the emission of hazardous or polluting fluids. The long-life and reliability of these systems also reduce your maintenance cost and downtime.

For applications requiring compliance with environmental protection regulations, the unique ENVIRO-SEAL packing system and, for hazardous service, the ENVIRO-SEAL bellows seal bonnet (figure 20) are offered. The patented emission control packing system or seal bonnet keeps emission concentrations below the EPA 100 ppm requirement.

For an excellent stem seal in applications that are not environmentally-sensitive, the HIGH-SEAL Graphite ULF packing system is offered. The HIGH-SEAL packing system provides excellent sealing at pressure/temperature ratings beyond ENVIRO-SEAL limits.

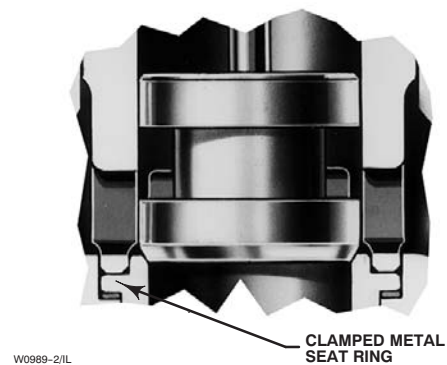
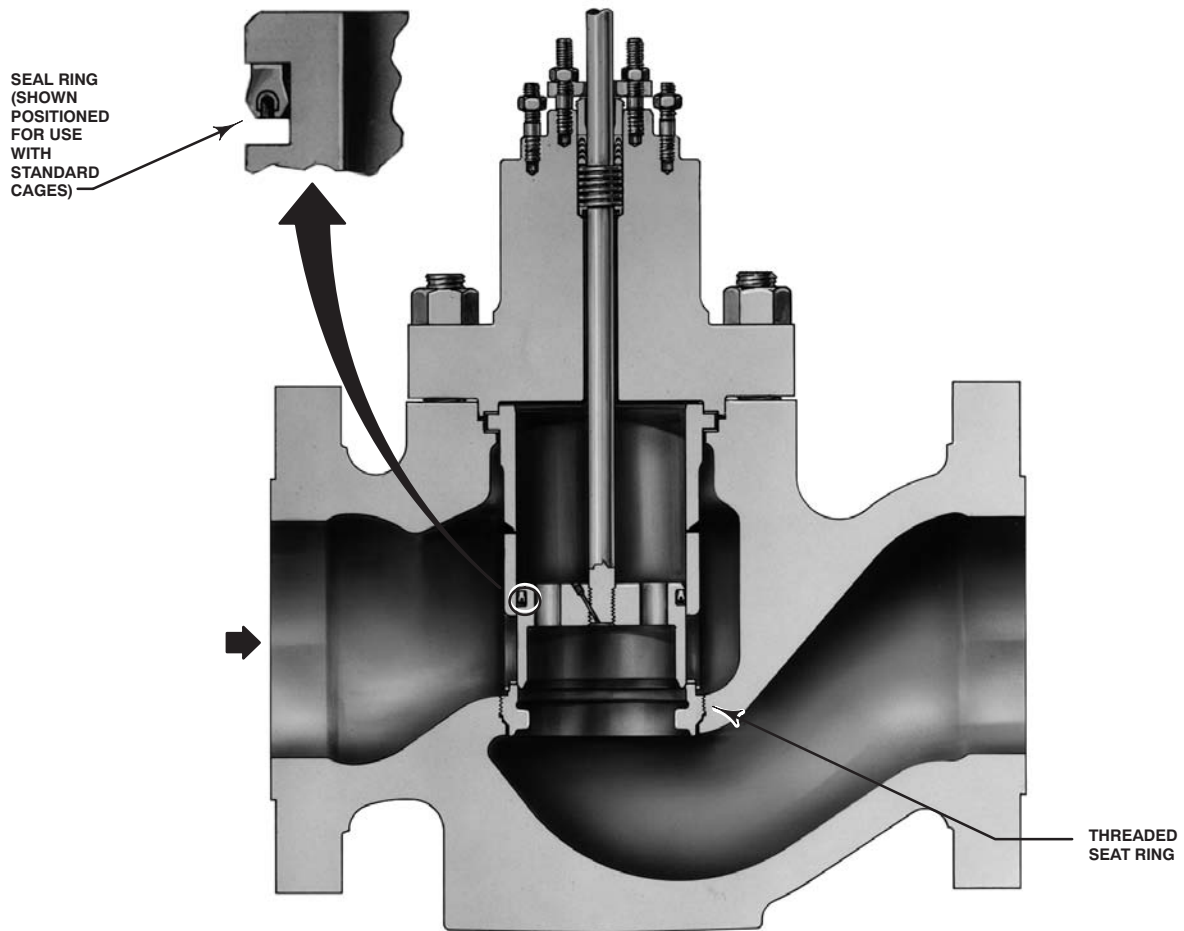

Figure 4. Fisher® EWS trim Details Showing Standard Cage and Seating Construction

ENVIRO-SEAL packing systems, available with PTFE, Graphite ULF, or Duplex packing, and the HIGH-SEAL Graphite ULF packing system feature live-loading and unique packing-ring arrangements for long-term, consistent sealing performance.



W9037

Figure 5. Fisher® NPS 12x8 CL900 EWT-1 Valve

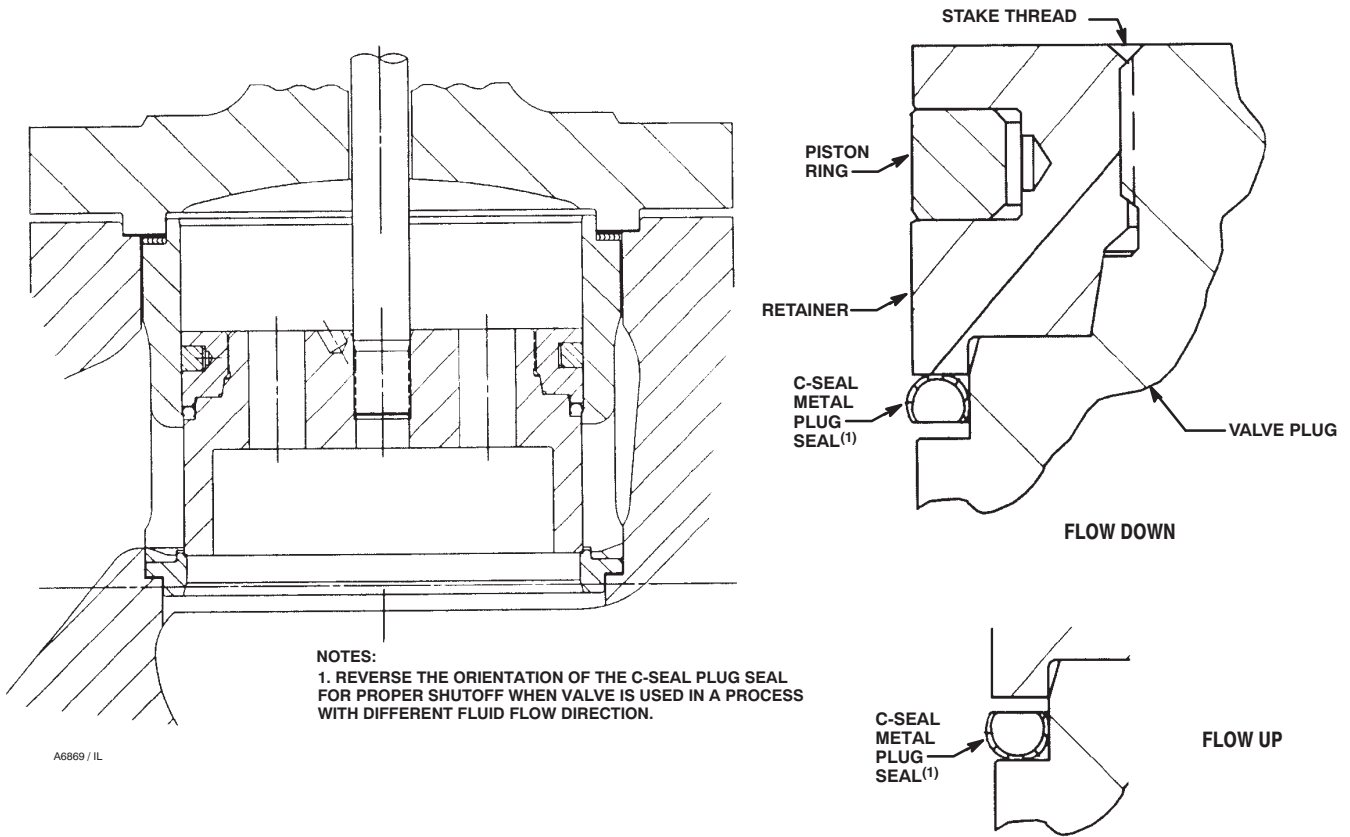

Figure 6. C-seal™ Trim

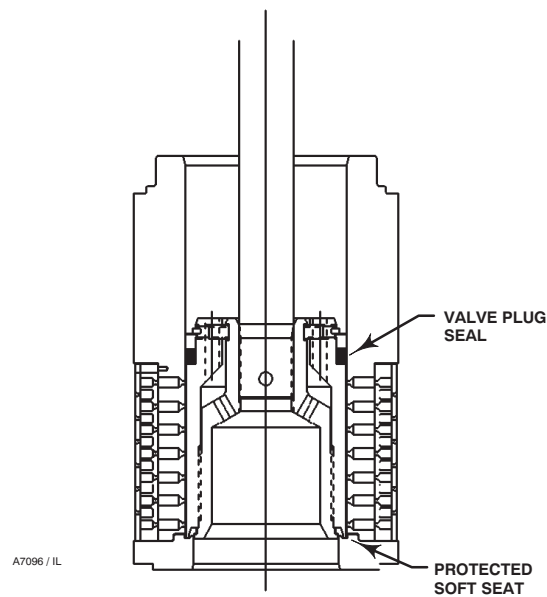
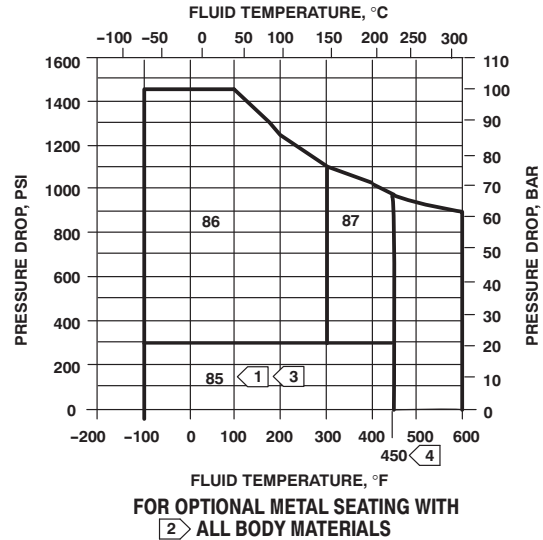
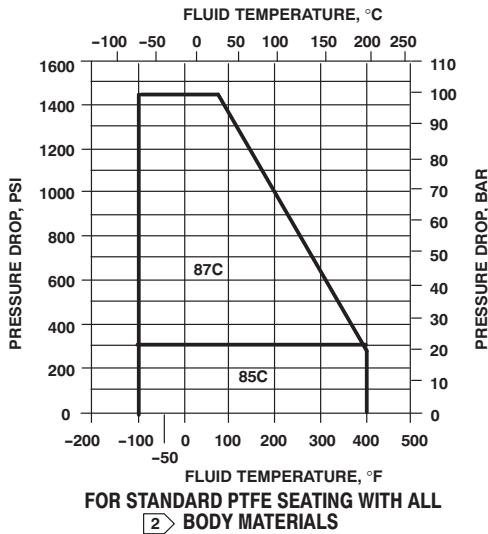

Figure 7. Typical Balanced TSO Trim

Table 1. Metal Trim Part Materials for Compatibility with NACE MR0175-2002 (Sour Service) Specifications, Environmental Restrictions Apply, Refer to Standard

Trim Designation	Valve Plug	Cage	Seat Ring for Standard Metal Seat Construction	Disk Seat and Retainer for Optional PTFE-Seat Construction	Valve Stem, Packing Follower, Lantern Ring, Packing Box Ring, and Pin	Load Ring ⁽¹⁾
85 ⁽³⁾	S31600	S31600 with electroless nickel coating (ENC)	S31600	---	S20910 (Valve Stem) S31600 (All Other Parts)	N05500
85C ^(2,3)	S31600	S31600 with electroless nickel coating (ENC)	---	S31600		
86 ⁽³⁾	S31600 with seat hard faced with CoCr-A hardfacing alloy	S31600 with electroless nickel coating (ENC)	R30006 (alloy 6)	---		
87	S31600 with seat and guide hard faced with CoCr-A hardfacing alloy	S31600 with electroless nickel coating (ENC)	R30006 (alloy 6)	---		
87C ⁽²⁾	S31600 with seat and guide hard faced with CoCr-A hardfacing alloy	S31600 with electroless nickel coating (ENC)	---	S31600		

1. NPS 10x8 and 12x8 valve body only.
 2. 85C and 87C are trims for PTFE-seat constructions in EWS and EWT valves.
 3. Not for use with Whisper Trim I with 5-3/8 inch and larger ports.



NOTES:
 1 USE TRIM 87 INSTEAD OF TRIM 85 FOR NONLUBRICATING FLUIDS SUCH AS SUPERHEATED STEAM OR DRY GASES BETWEEN 149°C (300°F) AND 316°C (600°F).
 2 DO NOT EXCEED THE MAXIMUM PRESSURE AND TEMPERATURE FOR THE CLASS RATING OF THE BODY MATERIAL USED, EVEN THOUGH THE TRIMS SHOWN MAY HAVE HIGHER CAPABILITIES.

3 USE TRIM 85 UP TO 99 BAR (1440 PSI) WITH CLEAN DRY GAS. FOR PROCESS FLUIDS OTHER THAN CLEAN DRY GAS, USE TRIM 85 ONLY UP TO 21 BAR (300 PSI).
 4 TRIM 87 TEMPERATURE LIMIT CAN BE EXTENDED ABOVE 232°C (450°F) IF PEEK ANTI-EXTRUSION RINGS AND SPRING-LOADED SEAL RING ARE USED.

A3115-3 / IL

Figure 8. Typical Trim for NACE MR0175-2002 (Sour Service)

Table 2. Available Valve Constructions⁽¹⁾

VALVE	VALVE SIZE ⁽²⁾ , NPS									
	CL150, 300, or 600								CL900	
	4x2	6x4	8x4	8x6	8x6 with NPS 10 ends	12x6	10x8	12x8	8x6	12x8
EWD	x	x	x	x	x	x	x	x	x	x
EWD-1	---	---	---	---	---	---	---	---	---	x
EWS	x	x	x	x	x	x	x	x	x	x
EWS-1	---	---	---	---	---	---	---	---	---	x
EWT	x	x	x	x	x	x	x	x	x	x
EWT-1	---	---	---	---	---	---	---	---	---	x

1. X indicates available construction.
2. Two-number valve size designates end connection size x trim size.

Available Configurations

All configurations covered in this bulletin use a single-port, globe-style valve body with cage guiding and push-down-to-close valve plug action. This valve style is combined with different plug styles and either a clamped seat ring (no dash number suffix) or a seat ring threaded into the valve body (-1 suffix).

EWD: Balanced valve plug (figure 2) with clamped seat ring and metal-to-metal seating for all general applications over a wide range of pressure drops and temperatures.

EWD-1: NPS 12x8 CL900 EWD valve body, with threaded seat ring.

EWS: Unbalanced valve plug (figure 4) with clamped seat ring and metal-to-metal or optional metal-to-PTFE seating for all general applications requiring better shutoff capabilities than can be obtained with the EWD valve body.

EWS-1: NPS 12x8 CL900 EWS valve body, with threaded seat ring and metal-to-metal seating.

EWT: Balanced valve plug (figure 3) with metal-to-PTFE seating (for stringent shutoff requirements) standard in all EWT valves (except those with Cavitrol III cages). Metal-to-metal seating for higher temperatures is standard for all EWT valve bodies with Cavitrol III cages and optional for these valves with other cages.

EWT-1: NPS 12x8 CL900 EWT valve body, with threaded seat ring and with metal-to-metal seating (figure 5).

Material Selection Guidelines

Regardless of valve construction, select the valve body/bonnet material from the specifications table,

keeping in mind that the valve service conditions cannot exceed the ASME pressure/temperature limitations for the selected valve body. Then, perform steps 1 and 2 under the appropriate valve design heading to complete the selection process.

EWD, EWS, or EWT Valve With All Except Cavitrol III or Whisper Trim III Cages

1. Choose a trim combination for the service conditions according to figure 9, while making sure from table 5 that this combination provides the desired trim materials. Then, make sure from table 11, 12, or 13 that the valve body/trim temperature limits are not exceeded.

2. Finally, check in table 20 that packing and other valve parts are available in materials that meet the desired service conditions.

EWD-1, EWS-1, or EWT-1 Valve With Standard Cage

1. Choose a trim combination for the service conditions according to figure 10, while making sure from table 7 that this combination provides the desired trim materials.

2. Finally, check in table 20 that packing and other valve parts are available in materials that meet the desired service conditions.

EWT Valve With Cavitrol III Cage

1. Choose a trim combination for the service conditions according to figure 13, while making sure from table 15 that this combination provides the desired trim materials. Then, make sure from table 16 that the valve body/trim temperature limits are not exceeded.

Table 3. Shutoff Classifications per ANSI/FCI 70-2 and IEC 60534-4

Valve	Seating	Shutoff Class
EWD or EWD-1	Metal	II (standard)
		III (optional for NPS 6x4 through 12x8 valves with optional graphite piston ring)
		IV (optional for NPS 6x4 through 12x8 valves with optional multiple graphite piston rings)
EWS or EWS-1	Metal	IV (standard)
		V (optional, consult your Emerson Process Management sales office)
EWS	PTFE	VI
EWT with all except Cavitrol III cages	PTFE	V (optional)
	Metal	IV V ⁽¹⁾
EWT with 1-stage Cavitrol III cage	Metal	IV (standard)
		V (optional)
EWT with 2-stage Cavitrol III cage or 2- or 3-stage Cavitrol III cage	Metal or PTFE	V
EWT-1	Metal	IV

1. Class V shutoff for EWT requires spring-loaded seal ring, radius-seat plug, and wide-bevel seat ring. Not available with 8-inch port, quick-opening cage. Not available with S31600 (316 SST) valve plug and seat ring (trims 4, 29, 85).

Table 4. C-seal™ Shutoff Classification

Valve	Valve Size, NPS	Port Diameter, mm (Inches)	Cage Style	ANSI/FCI Leakage Class
EWD (CL300, 600)	6x4x2-1/2	73 (2.875)	Eq. %, Linear, Whisper I, Cav III (2-stage)	V to 593°C (1100°F) (for port diameters from 73 through 203.2 mm (2.875 through 8-inch) with optional C-seal trim)
	6x4 8x4	111.1 (4.375)	Eq. %, Linear, Whisper I, Cav III (1-stage)	
	8x6 12x6	136.5 (5.375)	Whisper III (A3, B3, D3, D3), Cav III (2-stage)	
	8x6 12x6	177.8 (7)	Eq. %, Linear, Whisper I, Cav III (1-stage)	
	10x8 12x8	203.2 (8)	Eq. %, Linear, Whisper I, Cav III (1-stage)	

2. Finally, check in table 20 that packing and other valve parts are available in materials that meet the desired service conditions.

2. Finally, check in table 20 that packing and other valve parts are available in materials that meet the desired service conditions.

EWD, EWS, or EWT Valve With Whisper Trim III Cage

1. Choose a trim combination for the service conditions according to figure 16, while making sure from table 17 that this combination provides the desired trim materials. Then, make sure from table 18 that the valve body/trim temperature limits are not exceeded.

EWD-1, or EWT-1 Valve With Whisper Trim III Cage

1. Choose a trim combination for the service conditions according to figure 17 or 18, while making sure from table 19 that this combination provides the desired trim materials.

2. Finally, check in table 20 that packing and other valve parts are available in materials that meet the desired service conditions.

Table 5. Fisher® EWD, EWS, and EWT Metal Trim Part Combinations⁽¹⁾ Except for Valves with Cavitrol® III or Whisper Trim® III Cages

TRIM DESIGNATIONS	VALVE PLUG	CAGE	SEAT	
			Disk Seat, Retainer for PTFE Seat Constructions	Seat Ring for Metal Seat Constructions
1 (standard trim for all valves except EWT and those in CF8M. Trim 57 is standard for EWT. Trim 29 is standard for all valves in CF8M)	S41600 heat treated	CB7CU-1 (S17400) heat treated	---	■ S41600 or CA15 ⁽⁵⁾ (S41000) for Types EWD, EWS ■ CA6NM for Types EWD-1, EWS-1, EWT-1
3 and 3H ⁽²⁾	S31600 w/seat and guide hard faced w/CoCr-A hardfacing alloy	R30006 (alloy 6) ⁽³⁾	S31600 w/seat hard faced w/CoCr-A hardfacing alloy ⁽⁴⁾	S31600 w/seat hard faced w/CoCr-A hardfacing alloy ⁽⁴⁾
4 ⁽⁶⁾	S31600	CB7CU-1 (S17400) heat treated	S31600	S31600
27	S31600 w/seat and guide hard faced w/CoCr-A hardfacing alloy	CF8M w/electroless nickel coating (ENC)	S31600 w/seat hard faced w/CoCr-A hardfacing alloy ⁽⁴⁾	S31600 w/seat hard faced w/CoCr-A hardfacing alloy ⁽⁴⁾
29 ⁽⁶⁾ (standard for all valves in CF8M)	S31600	CF8M w/electroless nickel coating (ENC)	S31600	S31600
37 and 37H ⁽²⁾	S31600 w/seat and guide hard faced w/CoCr-A hardfacing alloy	CB7CU-1 (S17400) heat treated	S31600 w/seat hard faced w/CoCr-A hardfacing alloy ⁽⁴⁾	S31600 w/seat hard faced w/CoCr-A hardfacing alloy ⁽⁴⁾
57 (standard for all EWT valve bodies in all materials except CF8M)	S41600 heat treated	CB7CU-1 (S17400) heat treated	S31600	---

1. Nonferrous alloy combinations are also available. Consult your Emerson Process Management sales office for details.
 2. Trims 3H and 37H have clearances for high-temperature service.
 3. Available only in linear, quick-opening, equal percentage, and Whisper Trim I cages.
 4. Solid cast alloy 6 seat ring is used instead for NPS 4x2, 10x8, and 12x8 valve sizes.
 5. CA15 is used for NPS 8x6 CL900 EWD and EWS.
 6. Not for use with Whisper Trim I with 5-3/8 inch and larger ports.

ANSI/FCI Class VI Shutoff Capabilities

EWS valves with metal seat constructions and EWT valves with soft seat and metal seat constructions can provide ANSI/FCI Class VI shutoff capabilities. See tables 6 and 7.

Table 6. Class VI Shutoff Availability

Type	Port Size, Inches	Seat	Minimum Seat Load
EWS	≤ 7	Metal	300 lbs/lineal inch
EWT	≥ 3.4375 ≤ 7	Soft	See Catalog 14
EWT	≥ 3.4375 ≤ 7	Metal	300 lbs/lineal inch

Table 7. Class VI Trim Materials

TYPE	CAGE	VALVE PLUG	SEAT RING	SEAL RING	TRIM TEMPERATURE LIMIT	
					°C	°F
EWS	S31600 (316 SST) / ENC	S31600/CoCr-A (alloy 6) seat w/ radiused seat (special design)	S31600 w/ wide beveled seat (special design)	NA	Not a limiting factor	
EWT	S31600 / ENC	S31600 w/ standard beveled seat	S31600/PTFE	UHMWPE ⁽¹⁾ R30003	-29 to 66	-20 to 150
	S31600 / ENC	S31600/CoCr-A seat w/ radiused seat (special design)	S31600 w/ wide beveled seat (special design)	UHMWPE R30003	-101 to 66	-150 to 150
	S17400 (17-4PH SST)	S41600 w/ standard beveled seat	S31600/PTFE	UHMWPE R30003	-29 to 66	-20 to 150
	S17400	S41600 w/ radiused seat (special design)	S31600 w/ wide beveled seat (special design)	UHMWPE R30003	-29 to 66	-20 to 150

1. UHMWPE (Ultra High Molecular Weight Polyethylene)

Fisher TSO (Tight Shutoff) Trim Capabilities

See figure 7 and tables 8, 9, and 10. For additional information contact your Emerson Process Management sales office.

Table 8. TSO (Tight Shutoff) Leakage Class

Leakage Class	Maximum Leakage	Test Medium	Test Pressure	Test Procedure
TSO (Tight Shutoff)	Valves with TSO trim are factory tested to a more stringent Fisher test requirement of no leakage at time of shipment.	Water	Service $\Delta P^{(1)}$	ANSI/FCI Class V test procedure B

1. Specify service ΔP when ordering.

Table 9. TSO Shutoff Availability

TYPE	CONSTRUCTION
EWT	Std or Cavitrol III trim. Replaceable, protected soft seat

Table 10. Port Diameters, Valve Plug Travel, Yoke Boss Diameters for TSO (Tight Shutoff) Trim

VALVE TYPE	TRIM	MAX TRAVEL		YOKE BOSS SIZE		PORT DIAMETER				C _v REDUCTION AT 100% TRAVEL ⁽¹⁾
		mm	Inch	mm	Inch	Nominal		Actual TSO		
						mm	Inch	mm	Inch	
EWT NPS 6x4	Std	50.8	2	90	3-9/16	111	4.375	106	4.1875	4% (linear) 3% (equal percent)
EWT NPS 8x6	Std	50.8	2	90	3-9/16	179	7	173	6.8125	2%
		102	4	90	3-9/16					2%

1. This column lists the percent reduction of published maximum C_v of the trim listed in the TRIM column.

Installation

Unless limited by seismic criteria, the valve body can be installed in any position (as long as sufficient support is provided if a fabricated extension bonnet is used). However, the normal method is with the actuator vertical above the valve, since nonvertical positions may cause uneven trim wear and decreased trim life.

Flow through the valve body must be in the direction indicated by the flow direction arrow on the valve body. Consider installing an upstream strainer, especially if the valve body includes slotted or multihole Whisper Trim or Cavitrol cages.

Dimensions are shown in figure 21.

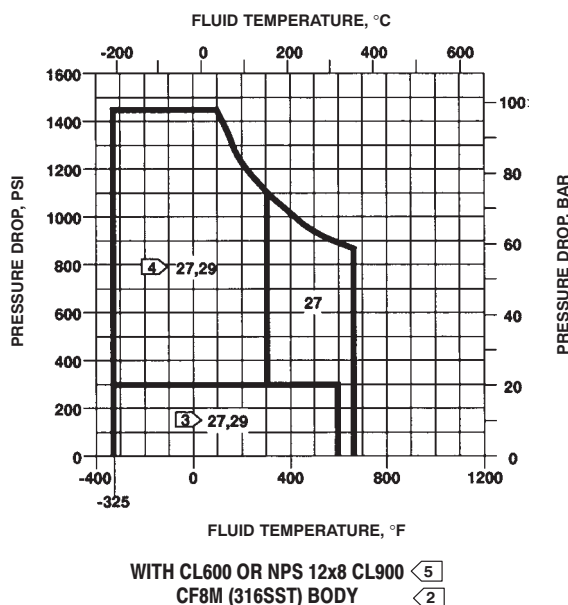
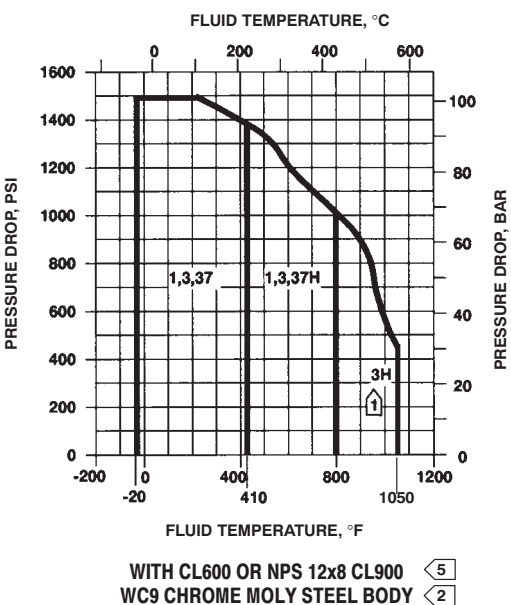
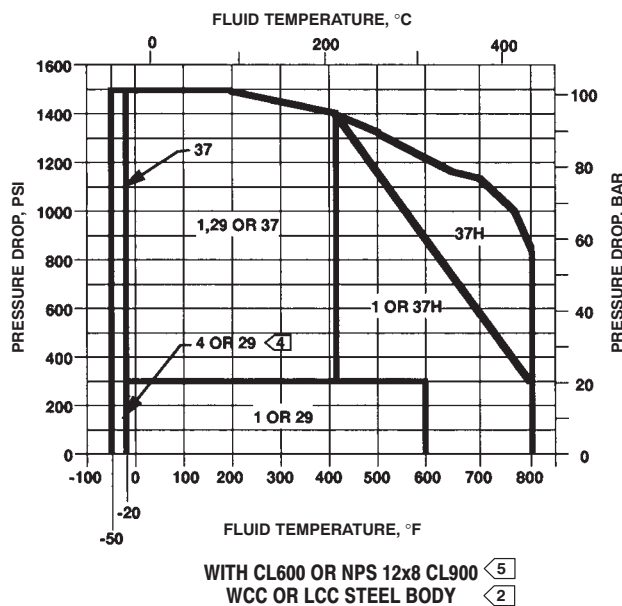
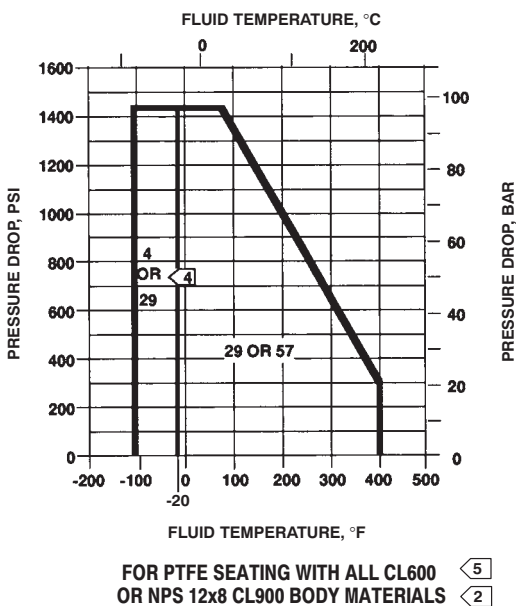

NOTES:

- 1 BE ESPECIALLY CAREFUL TO SPECIFY SERVICE TEMPERATURE IF TRIM 3, 4, OR 37 IS SELECTED, AS DIFFERENT THERMAL EXPANSION RATES REQUIRE SPECIAL PLUG CLEARANCES, ALSO, USE TRIM 37H INSTEAD OF TRIM 4 FOR NON-LUBRICATING FLUIDS SUCH AS SUPERHEATED STEAM OR DRY GASES BETWEEN 149°C (300°F) AND 316°C (600°F).
- 2 DO NOT EXCEED THE MAXIMUM PRESSURE AND TEMPERATURE FOR THE CLASS RATING OF THE BODY MATERIAL USED, EVEN THOUGH THE TRIMS SHOWN MAY HAVE HIGHER CAPABILITIES.

- 3 USE TRIM 27 INSTEAD OF TRIM 29 FOR NON-LUBRICATING FLUIDS SUCH AS SUPERHEATED STEAM OR DRY GASES BETWEEN 149°C (300°F) AND 316°C (600°F).
- 4 TRIMS 4 AND 29 MAY BE USED OVER 300 PSI ONLY WITH CLEAN, DRY GAS.
- 5 EWD, EWS, AND EWT NPS 12x8 CL900 LIMITED TO CL600 PRESSURE DROPS. SEE FIGURE 10 AND 11 EWD-1, EWS-1, AND EWT-1 FOR FULL CL900 NPS 12x8 PRESSURE DROPS.

A6334-1/IL

Figure 9. Typical Trim Used in Fisher® EWD, EWS, or EWT Valves Except Those with Cavitrol® III or Whisper Trim® III Cages (see tables 11, 12, and 13)

Table 11. Valve/Trim Temperature Capabilities⁽¹⁾ for CL300 or 600 Fisher® EWD, EWS, and EWT Valves with 2-Inch (51 mm) or 3-Inch (76 mm) Travel (Except those with Cavitrol® III or Whisper Trim® III Cages)

VALVE/BONNET MATERIAL	TRIM DESIGNATION FROM TABLE 5	VALVE SIZE, NPS	MATERIAL TEMPERATURE CAPABILITY					
			°C		°F			
			Min	Max	Min	Max		
WCC steel	1	4 x 2	-29	399	-20	750		
		6 x 4	-29	343	-20	650		
		8 x 4	-29	329	-20	625		
		8 x 6	-29	316	-20	600		
		12 x 6	-29	260	-20	500		
		12 x 8 and 10 x 8	-29	427	-20	800		
WCC steel	29	4 x 2	-29	316	-20	600		
		6 x 4	-29	221	-20	430		
		8 x 4	-29	218	-20	425		
		8 x 6	-29	204	-20	400		
		12 x 6	-29	174	-20	345		
		12 x 8 and 10 x 8	-29	316	-20	600		
WCC steel	37	4 x 2 through 12 x 8	-29	210	-20	410		
	37H	4 x 2 through 12 x 8	210	427	410	800		
	57	4 x 2 through 12 x 8	-29	204	-20	400		
	LCC steel	1	4 x 2	-29	371	-20	700	
			6 x 4	-29	343	-20	650	
8 x 4			-29	329	-20	625		
8 x 6			-29	329	-20	625		
12 x 6			-29	260	-20	500		
10 x 8 and 12 x 8			-29	343	-20	650		
LCC steel	57	4 x 2 through 10 x 8	-29	204	-20	400		
	29	4 x 2	-46	316	-50	600		
		6 x 4	-46	218	-50	425		
		8 x 4	-46	218	-50	425		
		8 x 6	-46	204	-50	400		
12 x 6		-46	163	-50	325			
LCC steel	29	10 x 8 and 12 x 8	-46	316	-50	600		
		37	4 x 2 through 12 x 8	-29	210	-20	410	
		37H	4 x 2 through 12 x 8	210	371	410	700	
		WC9 chrome moly steel	1	4 x 2	-29	399	-20	750
				6 x 4	-29	343	-20	650
8 x 4	-29			329	-20	625		
8 x 6	-29			316	-20	600		
12 x 6	-29			260	-20	500		
12 x 8 and 10 x 8	-29			427	-20	800		
WC9 chrome moly steel	3		4 x 2 through 12 x 8	-29	427	-20	800	
	3H		4 x 2 through 12 x 8	427	566	800	1050	
WC9 chrome moly steel	27		4 x 2	-29	343	-20	650	
			6 x 4	-29	221	-20	430	
			8 x 4	-29	218	-20	425	
		8 x 6	-29	204	-20	400		
		12 x 6	-29	163	-20	325		
		12 x 8 and 10 x 8	-29	343	-20	650		
	WC9 chrome moly steel	29	4 x 2	-29	316	-20	600	
			6 x 4	-29	221	-20	430	
			8 x 4	-29	218	-20	425	
			8 x 6	-29	204	-20	400	
WC9 chrome moly steel	29	12 x 6	-29	163	-20	325		
		12 x 8 and 10 x 8	-29	316	-20	600		
		37	4 x 2 thru 12 x 8	-29	210	-20	410	
		37H	4 x 2 thru 12 x 8	210	427	410	800	
		57	4 x 2 through 12 x 8	-29	204	-20	400	
CF8M (316 SST) ⁽²⁾	27	4 x 2 through 12 x 8	-198 ⁽³⁾	343	-325 ⁽³⁾	650		
	CF8M (316 SST) ⁽²⁾	29	4 x 2 through 12 x 8	-198 ⁽³⁾	316	-325 ⁽³⁾	600	

1. For metal trim parts only.
 2. For temperatures above 232°C (450°F), buttwelding-end CF8M valves having a CL600 pressure-temperature rating must be derated; contact your Emerson Process Management sales office for further information. Since ASME standards do not allow use of intermediate pressure-temperature ratings for flanged valves, flanged-end CF8M valves having a CL600 pressure-temperature rating must be limited to 232°C (450°F) or must be limited to inlet pressures that are consistent with the CL300 pressure-temperature rating.
 3. May be used down to -254°C (-425°F) if manufacturing process includes Charpy Impact test.

Table 12. 4-Inch (102 mm) Travel Whisper Trim® I Fisher® EWD and EWT Valve Body/Trim Temperature Capabilities⁽¹⁾
(CL150 - 600 and NPS 8 x 6, CL900)

BODY/BONNET MATERIAL ⁽²⁾	TRIM DESIGNATION FROM TABLE 5	VALVE SIZE, NPS	MATERIAL TEMPERATURE CAPABILITY			
			°C		°F	
			Min	Max	Min	Max
WCC steel	1	8 x 6 12 x 6	-29 -29	329 285	-20 -20	625 545
	3	8 x 6 or 12 x 6	-29	427	-20	800
	57	8 x 6 or 12 x 6	-29	204	-20	400
	37	8 x 6 or 12 x 6	-29	210	-20	410
	37H	8 x 6 12 x 6	210 210	427 363	410 410	800 685
LCC steel	1	8 x 6 only	-29	329	-20	625
	4, 57	8 x 6 only	-29	204	-20	400
	37	8 x 6 only	-29	210	-20	410
	37H	8 x 6 only	210	343	410	650
WC9 chrome moly steel	3	8 x 6 or 12 x 6	-29	427	-20	800
	3H	8 x 6 or 12 x 6	427	566	800	1050

1. For metal trim parts only.
2. Same material also used for bonnet spacer.

Table 13. Fisher® CL900 EWD, EWS, and EWT Valve Body/Trim Temperature Capabilities⁽¹⁾

BODY/BONNET MATERIAL	TRIM DESIGNATION FROM TABLE 5	VALVE SIZE, NPS	MATERIAL TEMPERATURE CAPABILITY			
			°C		°F	
			Min	Max	Min	Max
WCC steel	1	8 x 6 12 x 8	-29 -29	316 427	-20 -20	600 800
	29	8 x 6 12 x 8	-29 -29	204 316	-20 -20	400 600
	37	8 x 6 or 12 x 8	-29	210	-20	410
	37H	8 x 6 or 12 x 8	210	427	410	800
	57	8 x 6 or 12 x 8	-29	204	-20	400
LCC steel	1	8 x 6 only	-29	329	-20	625
	4, 37	8 x 6 only	-46	210	-50	410
	37H	8 x 6 only	210	371	410	700
	57	8 x 6 only	-29	204	-20	400
	29	8 x 6 only	-46	204	-50	400
WC9 chrome moly steel	1	8 x 6 12 x 8	-29 -29	316 427	-20 -20	600 800
	3	8 x 6	-29	427	-20	800
	3H	8 x 6	427	566	800	1050
	3	12 x 8	-29	427	-20	800
	3H	12 x 8	427	566	800	1050
	27	8 x 6 12 x 8	-29 -29	204 343	-20 -20	400 650
	29	8 x 6 12 x 8	-29 -29	204 316	-20 -20	400 600
	37	8 x 6 or 12 x 8	-29	210	-20	410
	37H	8 x 6 or 12 x 8	210	427	410	800
	57	8 x 6 or 12 x 8	-29	204	-20	400
316 SST (CF8M)	27	8 x 6 or 12 x 8	-198 ⁽²⁾	343	-325 ⁽²⁾	650
	29	8 x 6 or 12 x 8	-198 ⁽²⁾	316	-325 ⁽²⁾	600

1. For metal trim parts only.
2. May be used down to -254°C (-425°F) if manufacturing process includes Charpy impact test.

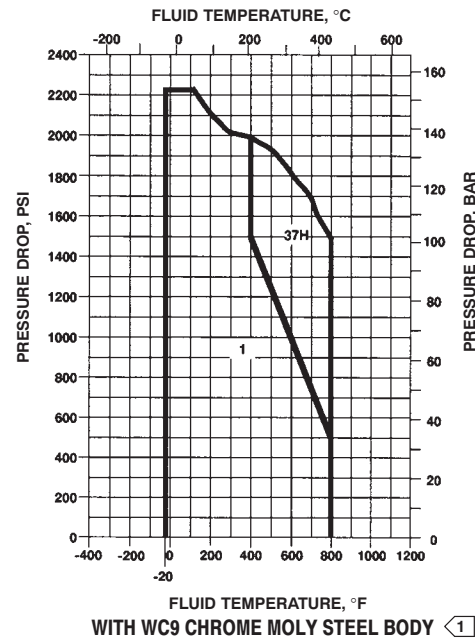
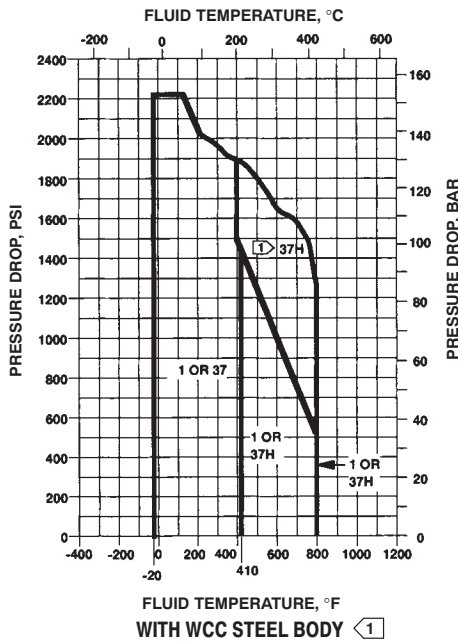

NOTE:
 1 DO NOT EXCEED THE MAXIMUM PRESSURE AND TEMPERATURE FOR THE CLASS RATING OF THE BODY MATERIAL USED, EVEN THOUGH THE TRIMS SHOWN MAY HAVE HIGHER CAPABILITIES.

Figure 10. Typical Trim Used in Fisher® EWD, EWS, and EWT NPS 8x6 CL900 Valves with Standard Cages and EWD-1, EWS-1, and EWT-1 NPS 12x8 CL900 Valves with Standard Cages (see table 14)

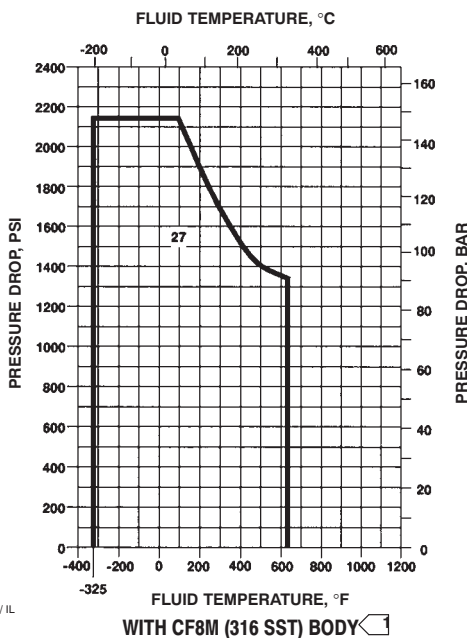

NOTE:
 1 DO NOT EXCEED THE MAXIMUM PRESSURE AND TEMPERATURE FOR THE CLASS RATING OF THE BODY MATERIAL USED, EVEN THOUGH THE TRIMS SHOWN MAY HAVE HIGHER CAPABILITIES.

Figure 11. Typical Trim Used in NPS 8x6 CL900 Fisher® EWD, EWS, EWT and NPS 12x8 CL900 EWD-1, EWS-1, and EWT-1 Valves with Standard Cages (see table 14)

Table 14. NPS 8x6 CL900 Fisher® EWD, EWS, EWT and NPS 12x8 CL900 EWD-1, EWS-1, and EWT-1 Metal Trim Part Combinations Except for Valves with Whisper Trim® III Cages

Trim Designation	Valve Plug	Cage	Seat Ring
1	S41600 (416 SST) heat treated	CB7CU-1 (17-4PH SST) with H900 heat-treat condition	Heat-treated CA6NM ⁽¹⁾
27	316 SST with seat and guide hard-faced with CoCr-A	316 SST with electroless nickel coating (ENC)	316 SST with seat hard-faced with CoCr-A
37 and 37H ⁽²⁾	S31600 with seat and guide hard-faced with CoCr-A	CB7CU-1 with H900 heat-treat condition	S31600 with seat hard-faced with CoCr-A

1. CA6NM is similar to 410 SST.
 2. Trim 37H has clearances for high-temperature service.

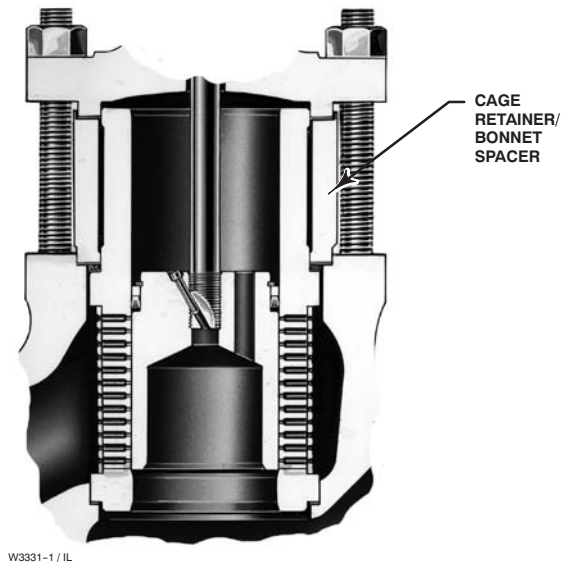
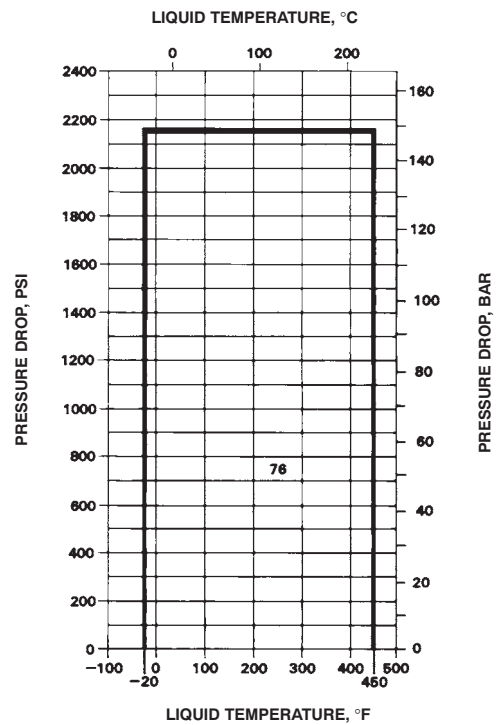

Figure 12. Detail of 2-Stage Cavitol® III Cage in CL300 or 600 Fisher® EWT Valve



NOTE:
DO NOT EXCEED THE MAXIMUM PRESSURE AND TEMPERATURE FOR THE CLASS RATING OF THE BODY MATERIAL USED, EVEN THOUGH THE TRIMS SHOWN MAY HAVE HIGHER CAPABILITIES.

A2732 / IL

Figure 13. Typical Trim Used in Cavitol® III Cage Constructions with Steel or Stainless Steel Valves (see tables 15)

Table 15. Cavitol® III⁽¹⁾ Metal Trim Part Combination

Trim Designation	Valve Plug	Cage	Cage Retainer ⁽²⁾	Seat Ring
76	Heat-treated S42000 (420 SST)	S17400 (17-4PH SST) with H900 heat-treat condition	S31600 (316 SST)	S17400 with H900 heat-treat condition

1. Available only in EWT valve.
2. Not used in NPS 12x8 or 8x6 CL900 valves.

Table 16. Cavitol® III Valve Body/Trim Temperature Capabilities

TRIM DESIGNATION FROM TABLE 15	VALVE BODY and BONNET	MATERIAL TEMPERATURE CAPABILITY				
		°C		°F		
		Min	Max	Min	Max	
76	WCC carbon steel or WC9 chrome moly steel	-29	These materials not limiting factors	-20	These materials not limiting factors	
	LCC carbon steel	-46		-50		
	S31600 (316 SST)	NPS 4x2 valve	-29	204	-20	400
		NPS 6x4 valve	-29	149	-20	300
		NPS 8x4 valve	-29	135	-20	275
		NPS 8x6 valve ⁽¹⁾	-29	121	-20	250
NPS 12x6 valve	-29	107	-20	225		
NPS 12x8 valve ⁽²⁾	-29	177	-20	350		

1. This valve body/trim combination not available in CL900 valve.
2. This valve body/trim combination available in all NPS 12x8 rating classes.

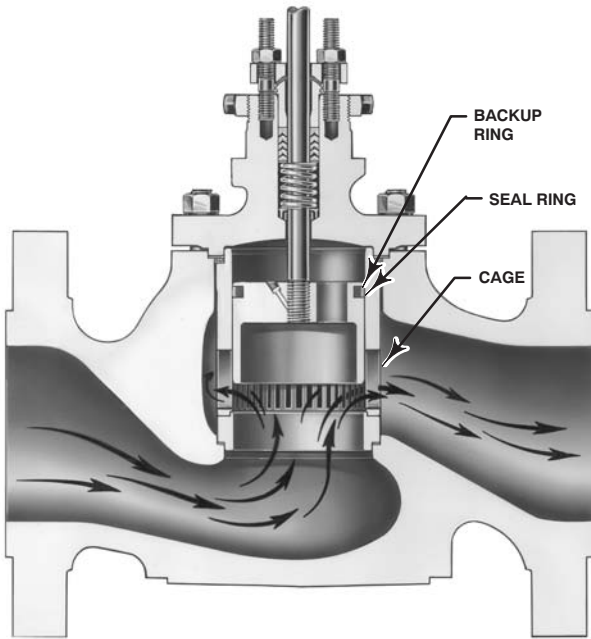

W9038

Figure 14. Fisher® EWT Metal-Seat Valve with Whisper Trim® I Cage

OPTIONAL TRIPLE PISTON RINGS USED TO OBTAIN CLASS IV SHUTOFF (THIS OPTIONAL SHUTOFF ALSO AVAILABLE IN OTHER EWD SIZES AND CONSTRUCTIONS)

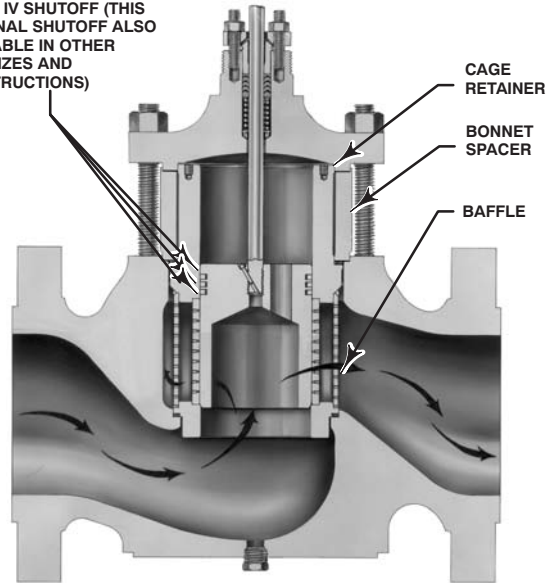

W9039

Figure 15. NPS 8x6 Fisher® EWD Valve with Whisper Trim® III Cage

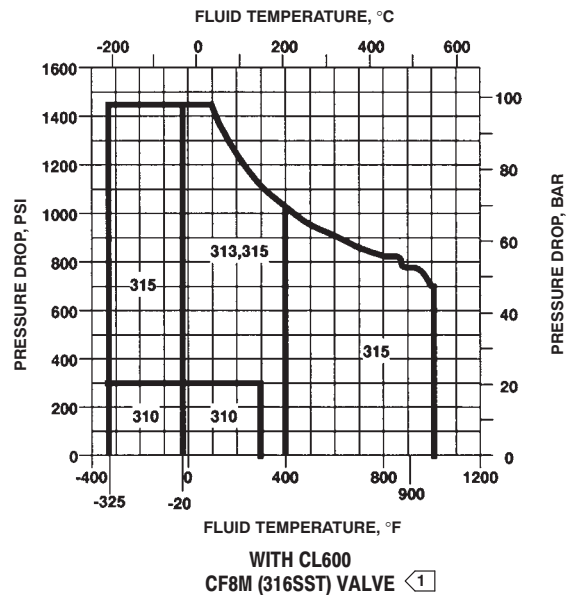
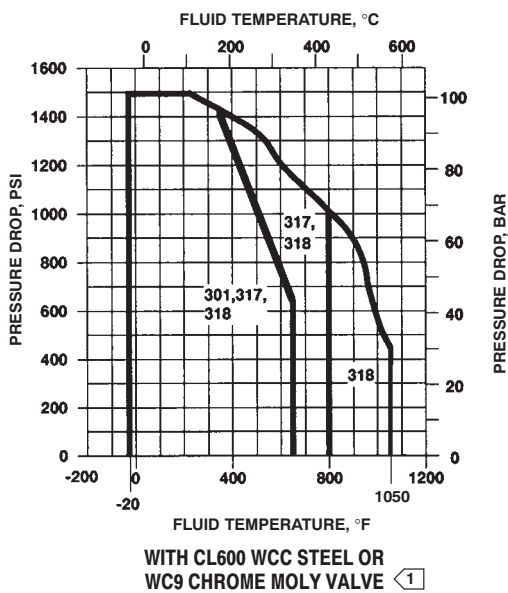

NOTE:
 1 DO NOT EXCEED THE MAXIMUM PRESSURE AND TEMPERATURE FOR THE CLASS RATING OF THE BODY MATERIAL USED, EVEN THOUGH THE TRIMS SHOWN MAY HAVE HIGHER CAPABILITIES.

A6334 / IL

Figure 16. Typical Trim Used in Fisher® EWD, EWS, and EWT Valves with Whisper Trim® III Cages (see table 17)

Table 17. Metal Trim Part Combinations for Fisher® EWD, EWS, and EWT Valves with Whisper Trim® III Cages⁽¹⁾

Trim Designation	Valve Plug	Cage	Cage Retainer	Baffle (for Level D3 Cage Only)	Disk Seat and Retainer for PTFE-Seat Construction	Seat Ring for Metal-Seat Construction
301 (standard for all valve materials except CF8M [316 SST])	S17400 (17-4PH SST) heat treated	S41600 (416 SST) heat treated	WCC/A105 heat-treated (NACE ⁽³⁾ with ENC)	Steel	---	S41600 (416 SST) heat treated
301C	S17400 (17-4PH SST) heat treated	S41600 (416 SST) heat treated	WCC/A105 heat-treated (NACE with ENC)	Steel	S31600 (316 SST)	---
304	S31600 with seat and guide hard-faced with CoCr-A (Alloy 6)	S41600 heat treated	WCC/A105 heat-treated (NACE with ENC)	Steel	---	S31600 with seat hard-faced with CoCr-A
312 (for level D NACE)	S31600 with seat and guide hard-faced with CoCr-A	S31600 with electroless nickel coating (ENC)	S31600 with electroless nickel coating (ENC)	S31600	---	S31600 with seat hard-faced with CoCr-A
313 (NACE compatible) ⁽²⁾	S31600 with seat and guide hard-faced with CoCr-A	S31600 with electroless nickel coating (ENC)	WCC/A105 heat-treated (NACE with ENC)	Steel	---	S31600 with seat hard-faced with CoCr-A
313C (NACE compatible) ⁽²⁾	S31600 with seat and guide hard-faced with CoCr-A	S31600 with electroless nickel coating (ENC)	WCC/A105 heat-treated (NACE with ENC)	Steel	S31600	---
315	S31600 with seat and guide hard-faced with CoCr-A	S31600 Cr Ct	S31600 Cr Ct	S31600	---	S31600 with seat hard-faced with CoCr-A
317	S31600 with seat and guide hard-faced with CoCr-A	WC9/Nitride	WCC/Nitride	Steel	---	S41600
318	S31600 with seat and guide hard-faced with CoCr-A	WC9/Nitride	WC9/Nitride	WC9	---	S31600 with seat hard-faced with CoCr-A

1. For NPS 8x6 or 12x6 valves only.
2. Level D3 cage cannot be certified to NACE. Use 316/ENC cage retainer instead.
3. Unless otherwise noted, all NACE references are to NACE MR0175-2002.

Table 18. Valve/Trim Temperature Capabilities for Fisher® EWD, EWS, and EWT Valves with Whisper Trim® III Cages

VALVE/BONNET/ BONNET SPACER MATERIAL	TRIM DESIGNATION FROM TABLE 17	VALVE SIZE, NPS	MATERIAL TEMPERATURE CAPABILITY			
			°C		°F	
			Min	Max	Min	Max
WCC steel or WC9 chrome moly steel	301	8 x 6 12 x 6	-29 -29	338 313	-20 -20	640 595
	301C (for soft seats)	8 x 6, 12 x 6	-29	204	-20	400
	304	8 x 6 12 x 6	-29 -29	343 338	-20 -20	650 640
	312	8 x 6 12 x 6	-29 -29	204 177	-20 -20	400 350
	313 (NACE ⁽²⁾ compatible)	8 x 6 12 x 6	-29 -29	232 204	-20 -20	450 400
	313C (NACE compatible) (for soft seats)	8 x 6 12 x 6	-29 -29	204 204	-20 -20	400 400
	315	8 x 6 12 x 6	-29 -29	204 177	-20 -20	400 350
	317	8 x 6, 12 x 6	-29	427	-20	800
	318 (WCC only)	8 x 6, 12 x 6	-29	427	-20	800
	318 (WC9 only)	8 x 6, 12 x 6	-29	593	-20	1100
CF8M (316 SST)	301, 301C (for soft seats), 304	8 x 6 12 x 6	-29 -29	149 121	-20 -20	300 250
	312	8 x 6 12 x 6	not a limiting factor			
	313	8 x 6, 12 x 6	-29	316	-20	600
	313C (for soft seats)	8 x 6, 12 x 6	-29	204	-20	400
	315	8 x 6, 12 x 6	-198	427 ⁽¹⁾	-325	800 ⁽¹⁾

1. May be used up to 538°C (1000°F) if manufacturing process controls carbon content to 0.04% minimum or 0.08% maximum.
 2. Unless otherwise noted, all NACE references are to NACE MR0175-2002.

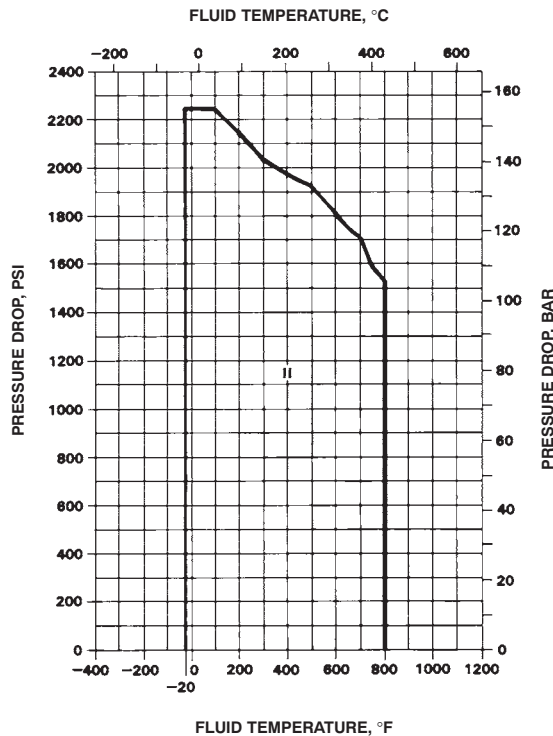

WITH STEEL OR CHROME MOLY STEEL VALVE 1

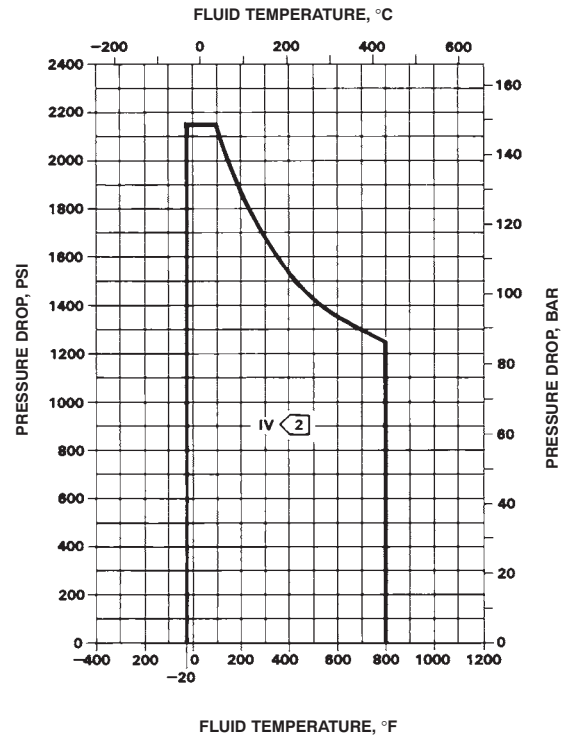

WITH CF8M (316 SST) VALVE 1

NOTE:

1 DO NOT EXCEED THE MAXIMUM PRESSURE AND TEMPERATURE FOR THE CLASS RATING OF THE BODY MATERIAL USED, EVEN THOUGH THE TRIMS SHOWN MAY HAVE HIGHER CAPABILITIES.

B1484-1 / IL

2 MAY BE USED DOWN TO -101°C (-150°F) WITH LEVEL A, B, OR C CAGE, OR WITH LEVEL D CAGE THAT HAS AN 18-8 SST BAFFLE.

Figure 17. Typical Trim Used in Fisher® EWD-1 Valves with Whisper Trim® III Cages (see table 19)

Table 19. Fisher® EWD-1 and EWT-1 Metal Trim Part Combinations for Valves with Whisper Trim® III Cages

Trim Designation	Valve Plug	Cage	Seat Ring
I	Heat-treated CA6NM ⁽¹⁾	CB7CU-1 (17-4PH SST) with H1025 heat-treat condition	Heat-treated CA6NM
II	S31600 (316 SST) with seat and guide hard faced with CoCr-A	CB7CU-1 with H1025 heat-treat condition	N06600 with seat hard faced with CoCr-A
IV	CF8M (316 SST) with seat and guide hard faced with CoCr-A	CB7CU-1 with H0125 heat-treat condition	CF8M with seat hard faced with CoCr-A

1. CA6NM is similar to 410 SST.

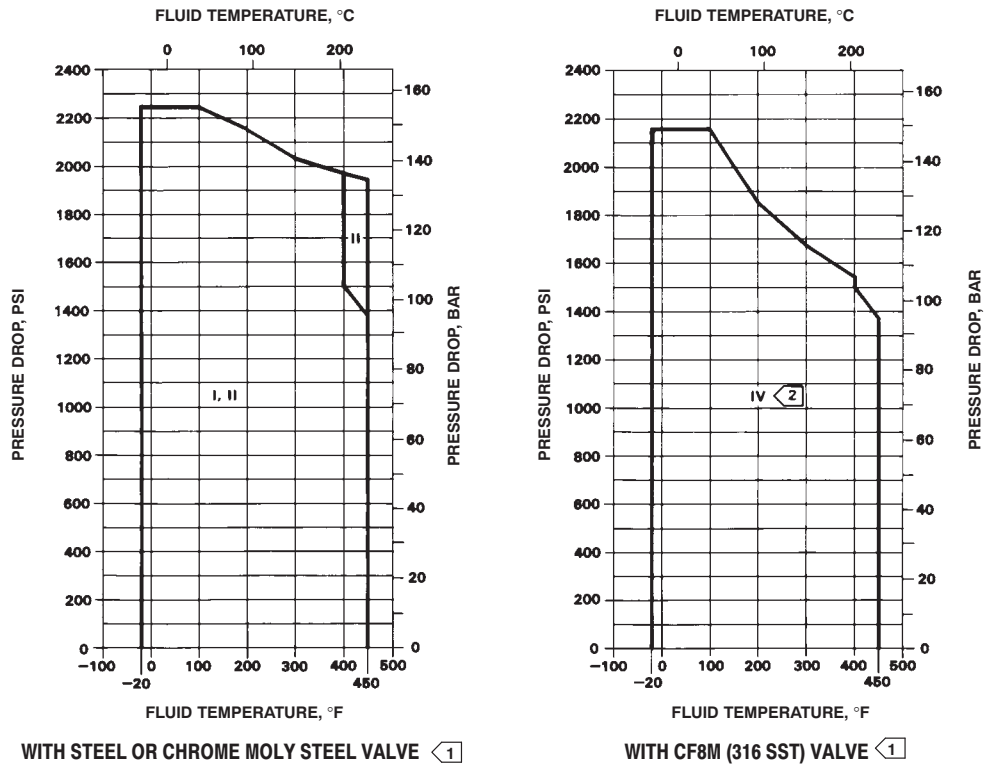

NOTE:

1 DO NOT EXCEED THE MAXIMUM PRESSURE AND TEMPERATURE RATING FOR THE CLASS RATING OF THE BODY MATERIAL USED, EVEN THOUGH THE TRIMS SHOWN MAY HAVE HIGHER CAPABILITIES.

A2733-1 / IL

2 MAY BE USED DOWN TO -101°C (-150°F) WITH LEVEL A, B, OR C CAGE, OR WITH LEVEL D CAGE THAT HAS AN 18-8 SST BAFFLE.

Figure 18. Typical Trim Used in Fisher® EWT-1 Valves with Whisper Trim® III Cages (see table 19)

Table 20. Materials and Temperature Limitations for Other Parts

PART			MATERIAL		MATERIAL TEMPERATURE CAPABILITY				
					°C		°F		
					Min	Max	Min	Max	
Body-to-bonnet bolting (see table 24 for NACE bolting materials and temperature limits)	WCC or WC9 valve body	Studs	Steel SA-193-B7, or steel SA-193-B7M for sour service		-29	427	-20	800	
		Nuts	Steel SA-194-2H, or steel SA-194-2M for sour service						
	LCC valve body	Studs	Steel SA-193-B7		-46	371	-50	700	
		Nuts	Steel SA-194-2H						
	WC9 valve body	Studs	Steel SA-193-B16		-29	593	-20	1100	
		Nuts	Steel SA-194-7						
	CF8M (316 SST) valve body	Studs	Steel SA-193-B7		-48	427	-55	800	
		Nuts	Steel SA-194-2H						
		Studs	Steel SA-193-B7M for sour service		-46	427	-50	800	
		Nuts	Steel SA-194-2HM for sour service		-46	343	-50	650	
		Studs	304 SST SA-320-B8		-254	38	-425	100	
		Nuts	304 SST SA-194-8						
		Studs	316 SST SA-193-B8M (strain hardened)		-198 ⁽¹⁾	427	-325 ⁽¹⁾	800	
		Nuts	316 SST SA-194-8M						
Studs	316 SST SA-193-B8M		-198 ⁽¹⁾	649	-325 ⁽¹⁾	1200			
Nuts	316 SST SA-194-8M								
Disk (all soft-seat constructions)			PTFE		-73	204	-100	400	
EWD piston ring	Std. for NPS 4x2 thru 12x6		Graphite (FMS 17F27)		-46 ⁽²⁾	427	-50 ⁽²⁾	800	
					-46 ⁽²⁾	482	-50 ⁽²⁾	900	
	Std. for NPS 10x8 and 12x8; optional for NPS 4x2 thru 12x6		Graphite FMS 17F39	Oxidizing service—all sizes	-46 ⁽²⁾	538	-50 ⁽²⁾	1000	
			Nonoxidizing service NPS 12x8 CL900 and 12x8 CL600 and smaller	-46 ⁽²⁾	593	-50 ⁽²⁾	1100		
Standard NPS 4x2 through 12x6 EWT valve plug seal (except valve with Cavitrol III cage)		Backup ring	Fluorocarbon ⁽³⁾		-18	204	0	400	
			Ethylene-propylene ⁽⁴⁾		-40	232	-40	450	
			Nitrile ⁽⁵⁾	For use with hydrocarbons		-34	71	-30	160
				For use with other fluids		-34	93	-30	200
			Seal ring		Carbon-filled PTFE		-73	232	-100
Spring-loaded EWT or EWT-1 valve plug seal ⁽⁶⁾ (standard for NPS 10x8 and 12x8 valve regardless of cage and all NPS 4x2 through 12x6 valves with Cavitrol III cage; optional in NPS 4x2 through 12x6 valves with other than Cavitrol III cages)		Backup ring	S41600 (416 SST)		-29	427	-20	800	
		Retaining ring	S30200 (302 SST)		-254	593	-425	1100	
		Seal ring	PTFE with N10276 Spring		-73	232 ⁽¹⁰⁾	-100	450 ⁽¹⁰⁾	
		Anti-extrusion rings	PEEK (PolyEtherEtherKetone)		. . . ⁽¹¹⁾		. . . ⁽¹¹⁾		
Valve plug stem and pin			S31600 (316 SST)		-198 ⁽¹⁾	593	-325 ⁽¹⁾	1100	
Load ring (NPS 10x8 and 12x8 EWD, EWS, and EWT only)			CB7CU-1 (17-4PH SST)		-102	316	-150	600	
			N07718 ⁽⁷⁾		-254	593	-425	1100	
			N05500 ⁽⁷⁾		-240	260	-400	500	
Seat ring, bonnet and cage gaskets			FGM (standard)		-198	593	-325	1100	
			PTFE-coated N04400		-73	149	-100	300	
Spiral wound gaskets			N06600 ⁽⁷⁾ /laminated graphite FGM (standard)		-198	593	-325	1100	

-continued-

Table 20. Materials and Temperature Limitations for Other Parts (Continued)

PART	MATERIAL	MATERIAL TEMPERATURE CAPABILITY				
		°C		°F		
		Min	Max	Min	Max	
Packing (temperatures shown are material temperature capabilities)	PTFE V-ring	-40	232	-40	450	
	PTFE/composition	-73	232	-100	450	
	Graphite ribbon/filament	-198	538 (9)	-325	1000 (9)	
	Graphite ribbon for high-temperature oxidizing service	371	649	700	1200	
Packing flange, studs and nuts when used with standard bonnet	S31600	-198 ⁽¹⁾	593	-325 ⁽¹⁾	1100	
Packing follower, and packing spring ⁽⁸⁾ or lantern ring	S31600	-198 ⁽¹⁾	593	-325 ⁽¹⁾	1100	
Packing box ring when used with standard bonnet	S31600					
Extension bonnet bushing	Trims 1 and 4	S41600	-29	427	-20	800
	Other trims	S31600	-198 ⁽¹⁾	593	-325 ⁽¹⁾	1100

1. May be used down to -254°C (-425°F) if manufacturing process includes Charpy impact test.
 2. This minimum is due to thermal expansion differential between piston ring and cage at low temperatures.
 3. For high-temperature air, hydrocarbons, and certain other chemicals and solvents, but cannot be used with ammonia, steam, or hot water.
 4. Has excellent moisture resistance to hot water and steam and may be used with most fire-resistant hydraulic oils, but cannot be used with petroleum-based fluids and other hydrocarbons.
 5. Cannot be used with fire-resistant hydraulic oils.
 6. May be used to increase hot water service capability to 232°C (450°F).
 7. This material may be used for cyclic temperatures or those above 232°C (450°F).
 8. Spring is used only with single PTFE V-ring packing; lantern ring replaces spring in other packings.
 9. Except 371°C (700°F) on oxidizing service.
 10. If used with PEEK anti-extrusion rings, PTFE/carbon seal ring may be used in temperatures up to 316°C (600°F) for non-oxidizing service or up to 260°C (500°F) for oxidizing service.
 11. These materials not limiting factors.

Table 21. Additional Specifications⁽¹⁾

VALVE SIZE, NPS	PORT DIAMETER		VALVE PLUG TRAVEL		STEM AND YOKE BOSS DIAMETERS								CAGE STYLE	
					Standard				Optional					
					Stem		Yoke Boss		Stem		Yoke Boss			
					mm	Inch	mm	Inch	mm	Inch	mm	Inch		
4 x 2	59	2.3125	29	1.125	12.7	1/2	71	2-13/16	19.1	3/4	90	3-9/16	Quick-opening, linear, equal percentage, Whisper Trim I, or Cavitrol ⁽¹⁾	
6 x 4, 8 x 4	111	4.375	51	2	12.7	1/2	71	2-13/16	25.4	1	127	5		
									31.8	1-1/4				
8 x 6, 12 x 6	178	7	51	2	19.1	3/4	90	3-9/16	25.4	1	127	5		
									31.8	1-1/4				
8 x 6, 12 x 6	178	7	76	3	19.1	3/4	90	3-9/16	25.4	1	127	5	Cavitrol only ⁽¹⁾	
			102 ⁽²⁾	4 ⁽²⁾	19.1	3/4	90	3-9/16	---	---			---	---
8 x 6	136	5.375	127 ⁽³⁾	5 ⁽³⁾	19.1	3/4	90	3-9/16	25.4	1	127	5	Whisper Trim III only	
12 x 6	136	5.375	165 ⁽³⁾	6.5 ⁽³⁾										
10 x 8	203	8	76	3	19.1	3/4	90	3-9/16	25.4	1	127	5	Quick-opening, linear, equal percentage only	
									31.8	1-1/4				
12 x 8	CL300 ⁽⁴⁾ or 600 ⁽⁴⁾	203	8	76	3	19.1	3/4	90	3-9/16	25.4	1	127	5	Quick-opening, linear, or equal percentage only
										31.8	1-1/4			
	CL900	203	8	76	3	25.4	1	127	5	19.1	3/4	90	3-9/16	
						31.8	1-1/4			31.8	1-1/4	127H ⁽⁵⁾	5H ⁽⁵⁾	
CL900	197 ⁽⁶⁾ or 172 ⁽⁷⁾	7.75 ⁽⁶⁾ or 6.75 ⁽⁷⁾	152	6	31.8	1-1/4	127	5	---	---	---	---	Whisper Trim III only	

1. Except for Cavitrol III cages, which are covered in separate documentation.
 2. Bonnet spacer required. This travel available only in CL300 or 600 EWD or EWT valve.
 3. Bonnet spacer required for EWD or EWT valve but not for EWS valve.
 4. Bonnet spacer required for EWD, EWS, and EWT valve.
 5. H indicates heavy actuator-to-bonnet bolting is required.
 6. Port diameter for level A, B, or C cage.
 7. Port diameter for level D cage.

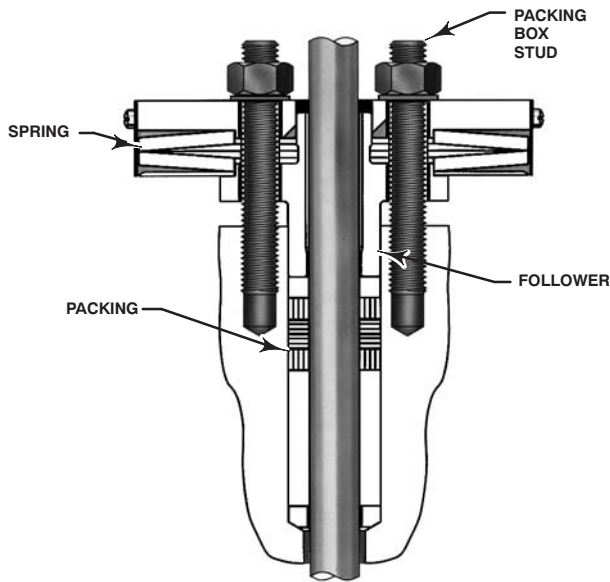

W6533-1

TYPICAL HIGH-SEAL PACKING SYSTEM WITH GRAPHITE ULF PACKING

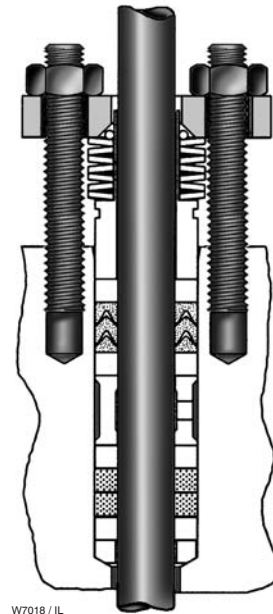

W7018 / IL

TYPICAL ENVIRO-SEAL PACKING SYSTEM WITH DUPLEX PACKING

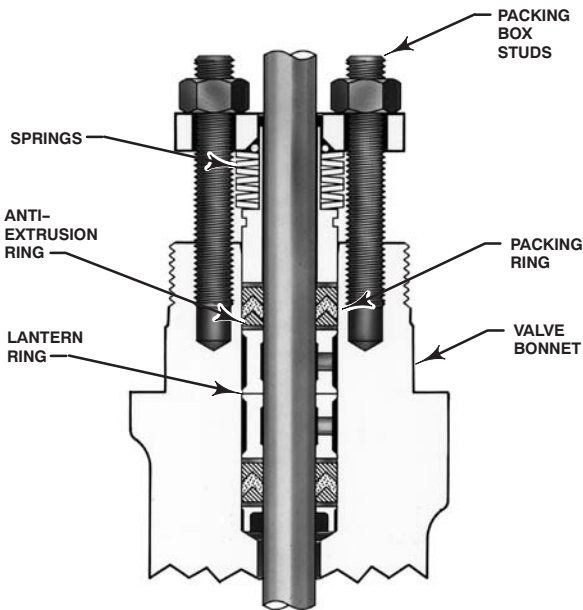

W5803-3 / IL

TYPICAL ENVIRO-SEAL PACKING SYSTEM WITH PTFE PACKING

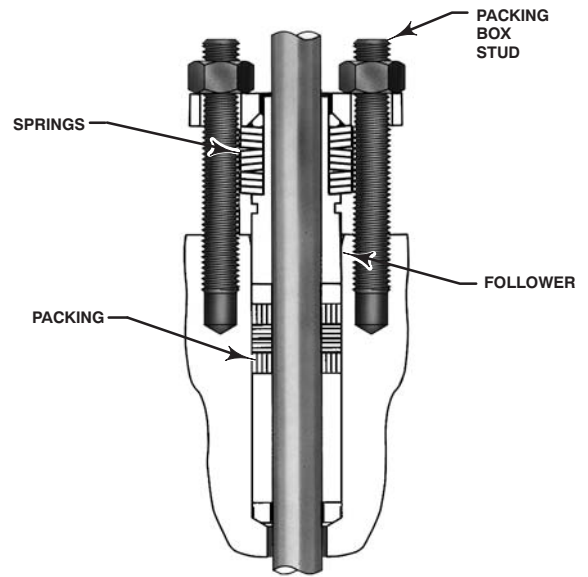

W8532-1

TYPICAL ENVIRO-SEAL PACKING SYSTEM WITH GRAPHITE ULF PACKING

Figure 19. Typical ENVIRO-SEAL® and HIGH-SEAL Packing Systems

Table 22. Approximate Weights

END CONNECTION		VALVE SIZE, NPS													
		4 x 2		6 x 4		8 x 4		8 x 6		12 x 6		10 x 8		12 x 8	
		kg	Lb	kg	Lb	kg	Lb	kg	Lb	kg	Lb	kg	Lb	kg	Lb
CL300		84	185	150	330	234	515	284	625	500	1102	567	1250	653	1440
CL600	Flanged	100	220	195	430	272	600	308	680	721	1590	744	1640	857	1890
	Buttwelding	61	135	122	270	177	390	272	600	526	1160	512	1130	658	1450
CL900	Flanged	---						612	1350	---				1361	3000
	Buttwelding	---						454	1000	---				1293	2850



W5852-1/IL

Figure 20. ENVIRO-SEAL® Bellows Seal Bonnet

Table 23. Bonnet Selection Guidelines

BONNET STYLE (CL300, 600) ⁽¹⁾	PACKING	IN-BODY PROCESS TEMPERATURE LIMITS ⁽²⁾	
		°C	°F
Plain Bonnet ■ Standard for NPS 2, 4, and 6 nominal trim sizes ■ Standard for NPS 10x8 and 12x8 valves (in cast iron, WCC). Not available in S31600	PTFE V-ring	-18 to 232	0 to 450
	PTFE/composition	-18 to 232	0 to 450
	Graphite ribbon/filament	-18 to maximum shown in table 20	0 to maximum shown in table 20
Style 1 Cast Extension Bonnet ■ Optional for NPS 2, 4, and 6 nominal trim sizes ■ Standard for NPS 10x8 and 12x8 valves (in S31600). Optional in WCC; not available in cast iron	PTFE V-ring	-46 to 427	-50 to 800
	PTFE/composition		
	Graphite ribbon/filament	to maximum shown in table 20	to maximum shown in table 20
Style 2 Cast Extension Bonnet ■ Optional for NPS 2, 4, and 6 nominal trim sizes ■ Optional for NPS 10x8 and 12x8 valves (in WCC). Not available in cast iron or S31600	PTFE V-ring	-101 to 427	-150 to 800
	PTFE/Composition		
	Graphite ribbon/filament	to maximum shown in table 20	to maximum shown in table 20
ENVIRO-SEAL Bellows Seal Bonnet ■ Optional for NPS 2, 4, 6, and 8 nominal trim sizes. Maximum travel is 2 inches	PTFE	For exceptional stem sealing capabilities. See Bulletin 59.1:070, ENVIRO-SEAL Bellows Seal Bonnets, for pressure/temperature ratings.	For exceptional stem sealing capabilities. See Bulletin 59.1:070, ENVIRO-SEAL Bellows Seal Bonnets, for pressure/temperature ratings.
	Graphite ULF		

1. For CL900 valve bodies, only the plain bonnet is available. Contact your Emerson Process Management sales office for assistance if application conditions indicate the need for an extension bonnet for a CL900 valve body.
 2. These in-body process temperatures assume an outside, ambient temperature of 21°C (70°F) and no insulation on the bonnet. When using any packing at low process temperatures, a cast extension bonnet may have to be used to prevent packing damage which could result from the formation of valve stem frost. Material selection for trim and other components will also be limiting factors.

Table 24. Bolting Materials and Temperature Limits for Bolting Compliance with NACE MR0175-2002, NACE MR0175/ISO 15156, and NACE MR0103. Environmental restrictions may apply.

VALVE BODY MATERIAL	BOLTING MATERIAL	TEMPERATURE CAPABILITIES					
		°C		°F			
		Min	Max	Min	Max		
Non-exposed bolting (Standard)							
WCC	Studs	Steel SA-193-B7		-7	232	20	450
	Nuts	Steel SA-194-2H					
	Studs	Steel SA-193-B7		232	427	450	800
	Nuts	Steel SA-194-2H lubricated					
CF8M (316 SST)	Studs	Steel SA-193-B7 or B8M strain hardened		-48	232	-55	450
	Nuts	Steel SA-194-2H or 8M					
	Studs	Steel SA-193-B8M strain hardened or B7		232	427	450	800
	Nuts	Steel SA-194-8M lubricated or 2H lubricated					
Exposed bolting (Optional)							
Requires Derating of Valve⁽²⁾ When These Body-to-Bonnet Bolting Materials are Used							
WCC and CF8M	Studs	Steel SA-193-B7M		-46 ⁽¹⁾	232	-50 ⁽¹⁾	450
	Nuts	Steel SA-194-2HM					
	Studs	Steel SA-193-B7M		232	427	450	800
	Nuts	Steel SA-194-2HM lubricated					

1. Minimum temperature is -29°C (-20°F) with WCC valve body material.
 2. Derating is not required for CL300 valves. Derating may be required for valves rated at CL600 or 900. Contact your Emerson Process Management sales office for assistance in determining the derating of valves when these body-to-bonnet bolting materials are used.

Table 25. Dimensions

VALVE SIZE, NPS	A								G (MAX)	
	Class, End Connection Style ⁽¹⁾								CL150, 300, and 600	CL900
	CL150	CL300		CL600		CL900				
	RF	RF	RTJ	RF, BW	RTJ	RF	RTJ	BW		
mm										
4 x 2	352	368 ⁽²⁾	384	394 ⁽²⁾	397	---	---	---	108	---
6 x 4	451	473 ⁽²⁾	489	508 ⁽²⁾	511	---	---	---	135	---
8 x 4	543	568 ⁽²⁾	584	610 ⁽²⁾	613	---	---	---	176	---
8 x 6 w/ NPS 10 Ends	543	568 ⁽²⁾	584	610 ⁽²⁾	613	914 ⁽³⁾	917	972	183	198
	---	603	619	625	629	---	---	---	183	---
12 x 6	737	775 ⁽²⁾	791	819 ⁽²⁾	822	---	---	---	254	---
10 x 8	673	708 ⁽²⁾	724	752 ⁽²⁾	756	---	---	---	275	---
12 x 8	737	775 ⁽²⁾	791	819 ⁽²⁾	822	902	905	953	356	356
Inch										
4 x 2	13.88	14.50 ⁽²⁾	15.12	15.50 ⁽²⁾	15.62	---	---	---	4.25	---
6 x 4	17.75	18.62 ⁽²⁾	19.25	20.00 ⁽²⁾	20.12	---	---	---	5.31	---
8 x 4	21.38	22.38 ⁽²⁾	23.00	24.00 ⁽²⁾	24.12	---	---	---	6.94	---
8 x 6 w/ NPS 10 Ends	21.38	22.38 ⁽²⁾	23.00	24.00 ⁽²⁾	24.12	36.00 ⁽³⁾	36.12	38.25	7.19	7.81
	---	23.75	24.38	24.62	24.75	---	---	---	7.19	---
12 x 6	29.00	30.50 ⁽²⁾	31.12	32.25 ⁽²⁾	32.38	---	---	---	10.00	---
10 x 8	26.50	27.88 ⁽²⁾	28.50	29.62 ⁽²⁾	29.75	---	---	---	10.81	---
12 x 8	29.00	30.50 ⁽²⁾	31.12	32.25 ⁽²⁾	32.38	35.50	35.62	37.50	14.00	14.00

1. End connection style abbreviations: RF - Raised Face, RTJ - Ring Type Joint, BW - Buttwelding.
 2. Per ISA S75.03.
 3. Per ISA S75.16.

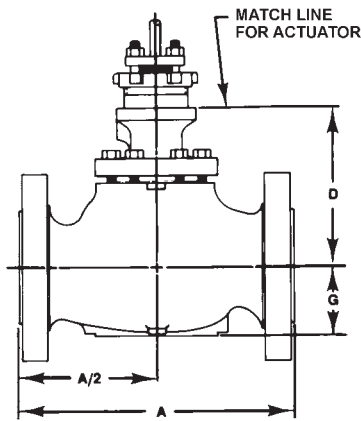

AV7029-K
A0921-1 / IL

TYPICAL OF NPS 4X2 THROUGH 10X8
(INCLUDING NPS 12X6)

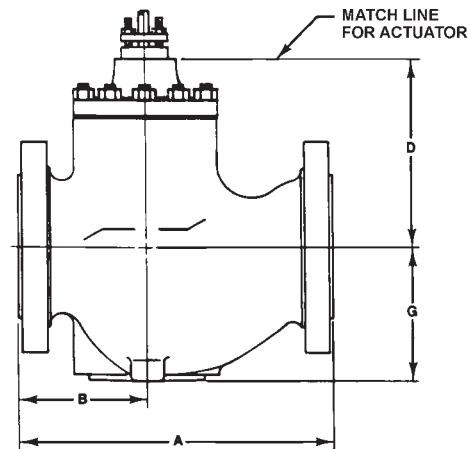

15A9682-C
A6108-1 / IL

TYPICAL OF NPS 12X8

E0979

Figure 21. Dimensions (also see tables 25, 26, and 27)

Table 26. Dimensions (Dimension B for 12 x 8 Valve Sizes)

VALVE SIZE, NPS	Class, End Connection Style ⁽¹⁾							
	CL150	CL300		CL600		CL900		
	RF	RF	RTJ	RF, BW	RTJ	RF	RTJ	BW
mm								
12 x 8	292	311	319	333	335	397	398	422
Inch								
12 x 8	11.50	12.25	12.56	13.12	13.18	15.63	15.69	16.63

Table 27. Dimensions (Dimension D for All Valve Sizes)

CAGE STYLE	BONNET	VALVE SIZE, NPS	STEM DIA									
			12.7 mm (1/2 Inch)		19.1 mm (3/4 Inch)				25.4 mm (1 Inch) or 31.8 mm (1-1/4 Inch)			
					CL900 Only		All Except CL900		CL300 and 600		CL900	
			mm	Inch	mm	Inch	mm	Inch	mm	Inch	mm	Inch
All except Cavitrol III or Whisper Trim III	Plain	4 x 2	216	8.50	---	---	213	8.38	---	---	---	---
		6 x 4	257	10.12	---	---	254	10.00	300	11.81	---	---
		8 x 4	259	10.19	---	---	256	10.06	302	11.88	---	---
		8 x 6	287	11.31	409	16.12	287	11.31	332	13.06	464	18.25
		12 x 6	356	14.00	---	---	356	14.00	400	15.75	---	---
		10 x 8	---	---	---	---	375	14.75	---	---	---	---
	Style 1 extension	4 x 2	317	12.50	---	---	322	12.69	---	---	---	---
		6 x 4	359	14.12	---	---	363	14.31	432	17.00	---	---
		8 x 4	360	14.19	---	---	365	14.38	433	17.06	---	---
		8 x 6	---	---	---	---	394	15.50	464	18.25	---	---
		12 x 6	---	---	---	---	462	18.19	532	20.94	---	---
		10 x 8	---	---	---	---	421	16.56	449	17.69	---	---
	Style 2 extension	4 x 2	516	20.31	---	---	513	20.19	---	---	---	---
		6 x 4	562	22.12	---	---	554	21.81	595	23.44	---	---
		8 x 4	564	22.19	---	---	556	21.88	597	23.50	---	---
		8 x 6	---	---	---	---	579	22.81	---	---	---	---
		10 x 8	---	---	---	---	621	24.44	---	---	---	---
		12 x 6	---	---	---	---	648	25.50	---	---	---	---
	ENVIRO-SEAL bellows seal bonnet	4 x 2	435	17.12	---	---	---	---	---	---	---	---
		6 x 4	576	22.69	---	---	576	22.69	---	---	---	---
		8 x 4	578	22.75	---	---	578	22.75	---	---	---	---
		10 x 8	---	---	---	---	703	27.69	---	---	---	---
		8 x 6	---	---	---	---	608	23.94	---	---	---	---
		12 x 6	---	---	---	---	676	26.62	---	---	---	---
Cavitrol III	Plain	4 x 2	252	9.94	---	---	249	9.81	---	---	---	---
		6 x 4	346	13.62	---	---	343	13.50	389	15.31	---	---
		8 x 4	348	13.69	---	---	344	13.56	---	---	---	---
		8 x 6	403	15.88	---	---	403	15.88	---	---	---	---
		10 x 8 ⁽¹⁾	---	---	---	---	375	14.75	425	16.75	---	---
		10 x 8 ⁽²⁾	---	---	---	---	511	20.12	560	22.06	---	---
		12 x 6	480	18.88	---	---	480	18.88	---	---	---	---
		12 x 8	---	---	---	---	---	---	---	---	---	---
Whisper	Plain	8 x 6	---	---	---	---	398	15.69	443	17.44	---	---
		12 x 6	---	---	---	---	503	19.81	548	21.56	---	---
		12 x 8	---	---	---	---	---	---	---	---	---	---

1. One-stage trim.
2. Two-stage trim.

Coefficients

Table 28. Fisher® EWD, CL150, 300, and 600, Quick Opening and Linear Cages, Flow Down Through the Port

Quick Opening																Quick Opening Characteristic	
Valve Size, NPS ⁽¹⁾	Port Diameter		Coeffs. for 0.25 in. (6 mm) Travel ⁽²⁾	Maximum Travel		Flow Coefficient	Valve Opening—Percent of Total Travel										F _L ⁽³⁾
	mm	Inches		mm	Inches		10	20	30	40	50	60	70	80	90	100	
4 x 2	58.7	2.3125	29.8	29	1.125	C _V	13.8	26.5	42.7	61.8	78.1	93.3	105	114	119	124	0.82
						K _V	11.9	22.9	36.9	53.5	67.6	80.7	90.8	98.6	103	107	---
						X _T	0.571	0.651	0.662	0.648	0.687	0.708	0.714	0.709	0.713	0.693	---
6 x 4	111.1	4.375	49.3	51	2	C _V	40.8	85.3	140	196	242	277	306	326	340	340	0.88
						K _V	35.3	73.8	121	170	209	240	265	282	294	294	---
						X _T	0.577	0.594	0.612	0.656	0.732	0.779	0.793	0.791	0.804	0.818	---
8 x 4	111.1	4.375	52.7	51	2	C _V	43.2	88.7	147	202	252	294	328	354	371	379	0.89
						K _V	37.4	76.7	127	175	218	254	284	306	321	328	---
						X _T	0.629	0.650	0.631	0.677	0.726	0.797	0.809	0.817	0.815	0.817	---
8 x 6	177.8	7	96.2	51	2	C _V	79.0	158	247	338	413	471	531	569	610	637	0.89
						K _V	68.3	137	214	292	357	407	459	492	528	551	---
						X _T	0.544	0.574	0.578	0.626	0.678	0.758	0.759	0.749	0.727	0.705	---
12 x 6	177.8	7	98.0	51	2	C _V	80.1	156	250	348	449	539	621	683	743	817	0.82
						K _V	69.3	135	216	301	388	466	537	591	643	707	---
						X _T	0.515	0.627	0.613	0.624	0.642	0.689	0.715	0.765	0.789	0.782	---
10 x 8	203.2	8	---	76	3	C _V	138	306	468	607	725	824	903	960	998	1040	0.88
						K _V	119	265	405	525	627	713	781	830	863	900	---
						X _T	0.665	0.632	0.651	0.685	0.708	0.722	0.741	0.761	0.791	0.787	---
12 x 8	203.2	8	---	76	3	C _V	149	315	481	640	780	898	1000	1100	1180	1260	0.79
						K _V	129	272	416	554	675	777	865	952	1021	1090	---
						X _T	0.687	0.735	0.727	0.745	0.754	0.784	0.744	0.754	0.711	0.636	---
Linear																Linear Characteristic	
4 x 2	58.7	2.3125	---	29	1.125	C _V	6.80	14.6	23.0	32.7	43.9	56.6	70.8	85.0	97.2	107	0.79
						K _V	5.88	12.6	19.9	28.3	38.0	49.0	61.2	73.5	84.1	92.6	---
						X _T	0.625	0.659	0.691	0.682	0.645	0.604	0.582	0.603	0.632	0.654	---
6 x 4	111.1	4.375	---	51	2	C _V	21.4	49.0	78.7	109	137	166	201	245	286	320	0.86
						K _V	18.5	42.4	68.1	94.3	119	144	174	212	247	277	---
						X _T	0.686	0.717	0.651	0.648	0.654	0.661	0.672	0.670	0.695	0.725	---
8 x 4	111.1	4.375	---	51	2	C _V	23.2	51.0	80.6	111	141	173	211	254	299	340	0.82
						K _V	20.1	44.1	69.7	96.0	122	150	183	220	259	294	---
						X _T	0.694	0.711	0.691	0.661	0.668	0.669	0.676	0.688	0.727	0.753	---
8 x 6	177.8	7	---	51	2	C _V	44.0	108	170	234	293	354	405	474	552	617	0.88
						K _V	38.1	93.4	147.1	202	253	306	350	410	477	534	---
						X _T	0.796	0.726	0.758	0.742	0.772	0.767	0.801	0.748	0.702	0.656	---
12 x 6	177.8	7	---	51	2	C _V	51.7	111	176	249	319	391	458	540	632	729	0.81
						K _V	44.7	96.0	152	215	276	338	396	467	547	631	---
						X _T	0.716	0.710	0.691	0.656	0.639	0.639	0.661	0.649	0.639	0.633	---
10 x 8	203.2	8	---	76	3	C _V	95.9	212	336	459	586	696	798	876	928	975	0.91
						K _V	83.0	183	291	397	507	602	690	758	803	843	---
						X _T	0.683	0.617	0.610	0.641	0.657	0.694	0.715	0.748	0.795	0.843	---
12 x 8	203.2	8	---	76	3	C _V	104	223	348	490	638	781	907	999	1080	1160	0.80
						K _V	90.0	193	301	424	552	676	785	864	934	1003	---
						X _T	0.700	0.694	0.647	0.692	0.697	0.693	0.711	0.741	0.738	0.696	---

1. The first number indicates both body inlet and outlet sizes. The second number indicates nominal port size.
 2. When sizing self-operated regulators, use coefficients listed for 6mm (0.25 inch) travel.
 3. At 100% travel.

Notes: The coefficients shown on this page are also appropriate for the EWT.

Table 29. Fisher® EWD, CL150, 300, and 600, Equal Percentage Cages

Equal Percentage (Flow Down)														Equal Percentage Characteristic		
Valve Size, NPS ⁽¹⁾	Port Diameter		Maximum Travel		Flow Coefficient	Valve Opening—Percent of Total Travel										FL ⁽²⁾
	mm	Inches	mm	Inches		10	20	30	40	50	60	70	80	90	100	
4 x 2	58.7	2.3125	29	1.125	C _V	2.53	4.52	6.66	9.29	13.6	19.9	29.4	45.2	65.8	82.2	0.82
					K _V	2.19	3.91	5.76	8.04	11.8	17.2	25.4	39.1	56.9	71.1	---
					X _T	0.626	0.652	0.664	0.683	0.657	0.66	0.646	0.591	0.560	0.587	---
6 x 4	111.1	4.375	51	2	C _V	7.34	13.1	19.8	30.6	46.6	69.1	108	168	225	271	0.87
					K _V	6.35	11.3	17.1	26.5	40.3	59.8	93.4	145	195	234	---
					X _T	0.996	0.808	0.711	0.640	0.605	0.605	0.630	0.613	0.662	0.712	---
8 x 4	111.1	4.375	51	2	C _V	8.01	14.1	21.1	31.7	47.2	73.5	118	180	240	286	0.85
					K _V	6.93	12.2	18.3	27.4	40.8	63.6	102	156	208	247	---
					X _T	0.684	0.671	0.643	0.617	0.566	0.591	0.566	0.573	0.645	0.675	---
8 x 6	177.8	7	51	2	C _V	13.2	26.4	45.4	71.1	112	178	256	342	431	508	0.91
					K _V	11.4	22.8	39.3	61.5	96.9	154	221	296	373	439	---
					X _T	0.837	0.837	0.719	0.683	0.596	0.573	0.626	0.682	0.688	0.684	---
12 x 6	177.8	7	51	2	C _V	23.6	36.2	52.8	76.3	110	164	248	348	453	565	0.79
					K _V	20.4	31.3	45.7	66.0	95.2	142	215	301	392	489	---
					X _T	0.628	0.664	0.694	0.714	0.703	0.739	0.695	0.683	0.658	0.627	---
10 x 8	203.2	8	76	3	C _V	32.3	65.7	111	184	303	462	635	778	876	924	0.89
					K _V	27.9	56.8	96.0	159	262	400	549	673	758	799	---
					X _T	0.725	0.720	0.687	0.634	0.585	0.582	0.595	0.615	0.652	0.802	---
12 x 8	203.2	8	76	3	C _V	28.4	61.0	112	196	311	481	687	839	992	1090	0.81
					K _V	24.6	52.8	96.9	170	269	416	594	726	858	943	---
					X _T	0.666	0.665	0.667	0.664	0.659	0.667	0.664	0.662	0.663	0.663	---

1. The first number indicates both body inlet and outlet sizes. The second number indicates nominal port size.
 2. At 100% travel.

Table 30. Fisher® EWD, CL150, 300, and 600, Whisper Trim® I Cages

Whisper Trim I (Flow Up)															Linear Characteristic	
Valve Size, NPS ⁽¹⁾	Port Diameter		Maximum Travel		Flow Coefficient	Valve Opening—Percent of Total Travel										FL ⁽²⁾
	mm	Inches	mm	Inches		10	20	30	40	50	60	70	80	90	100	
4 x 2	58.7	2.3125	29	1.125	C _V	14.8	28.9	40.8	52.9	65.1	77.2	89.0	100	111	118	---
					K _V	12.8	25.0	35.3	45.8	56.3	66.8	77.0	86.5	96.0	102	---
					X _T	0.320	0.323	0.323	0.322	0.323	0.321	0.322	0.325	0.324	0.322	---
6 x 4	111.1	4.375	51	2	C _V	30.9	69.9	110	149	187	223	253	281	307	325	---
					K _V	26.7	60.5	95.2	129	162	193	219	243	266	281	---
					X _T	0.668	0.476	0.382	0.351	0.349	0.358	0.367	0.382	0.401	0.416	---
8 x 4	111.1	4.375	51	2	C _V	36.2	77.6	116	155	193	231	266	298	326	345	---
					K _V	31.3	67.1	100	134	167	200	230	258	282	298	---
					X _T	0.447	0.403	0.356	0.333	0.331	0.329	0.334	0.341	0.350	0.368	---
8 x 6	177.8	7	51	2	C _V	42.8	99.7	164	224	290	352	422	473	523	545	---
					K _V	37.0	86.2	142	194	251	304	365	409	452	471	---
					X _T	0.550	0.409	0.364	0.350	0.334	0.326	0.310	0.326	0.329	0.350	---
			102 ⁽³⁾	4 ⁽³⁾	C _V	113	266	355	475	522	522	522	522	519	522	---
					K _V	97.7	230	307	411	452	452	452	452	449	452	---
					X _T	0.412	0.285	0.357	0.354	0.469	0.632	0.777	0.854	0.919	0.917	---
12 x 6	177.8	7	51	2	C _V	49.0	126	196	269	340	406	476	540	598	641	---
					K _V	42.4	109	170	233	294	351	412	467	517	554	---
					X _T	0.547	0.300	0.286	0.270	0.264	0.267	0.263	0.264	0.273	0.273	---
			102 ⁽³⁾	4 ⁽³⁾	C _V	113	258	343	469	572	641	755	828	884	953	---
					K _V	97.7	223	297	406	495	554	653	716	765	824	---
					X _T	0.432	0.320	0.393	0.363	0.380	0.424	0.408	0.437	0.468	0.476	---
10 x 8	203.2	8	76 ^(4,5)	3 ^(4,5)	C _V	99.2	229	339	430	515	605	691	763	806	826	---
					K _V	85.8	198	293	372	515	523	598	660	697	714	---
					X _T	0.791	0.490	0.439	0.447	0.462	0.465	0.463	0.478	0.518	0.591	---
			102 ⁽⁶⁾	4 ⁽⁶⁾	C _V	146	300	433	551	664	755	824	857	866	903	---
					K _V	126	260	375	477	574	653	713	741	749	781	---
					X _T	0.596	0.465	0.441	0.451	0.459	0.488	0.535	0.616	0.720	0.761	---
12 x 8	203.2	8	76	3	C _V	147	268	358	445	537	624	702	772	842	900	---
					K _V	127	232	310	385	465	540	607	668	728	779	---
					X _T	0.256	0.272	0.390	0.422	0.406	0.411	0.439	0.473	0.480	0.508	---
			102	4	C _V	181	329	449	563	674	778	866	931	972	1000	---
					K _V	157	285	388	487	583	673	749	805	841	865	---
					X _T	0.329	0.350	0.408	0.425	0.431	0.452	0.494	0.540	0.583	0.644	---

1. The first number indicates both body inlet and outlet size. The second number indicates nominal port size.
 2. At 100% travel.
 3. Travel limited to 3.5 inches when optional multiple piston ring is used. Reduce printed capacities accordingly.
 4. Travel limited to 70 mm (2.75 inches) with Class IV ED valve plug.
 5. Travel limited to 64 mm (2.5 inches) with anti-extrusion rings or EWT-C valve plug.
 6. Travel limited to 95 mm (3.75 inches) with anti-extrusion rings or EWT-C valve plug.

Notes: The coefficients shown on this page are also appropriate for the EWT.

Table 31. Fisher® EWD, CL150, 300, and 600, Whisper Trim® III Cage

Whisper Trim III															Linear Characteristic ⁽¹⁾	
Valve Size, NPS ⁽²⁾	Port Diameter		Maximum Travel		Flow Coefficient	Valve Opening—Percent of Total Travel										X _T ⁽⁴⁾
	mm	Inches	mm	Inches		Minimum ⁽³⁾	20	30	40	50	60	70	80	90	100	
A3 ΔP/P₁ ≤ 0.6																
8 x 6	136.5	5.375	127	5	C _v	4.00	97.6	159	215	270	326	383	427	457	460	0.710
					K _v	3.46	84	138	186	234	282	331	369	395	398	---
12 x 6	136.5	5.375	165	6.5	C _v	4.00	151	238	324	407	492	573	651	697	698	0.589
					K _v	3.46	131	206	280	352	426	496	563	603	604	---
B3 ΔP/P₁ ≤ 0.75																
8 x 6	136.5	5.375	127	5	C _v	4.67	72.3	108	143	178	213	248	280	314	347	0.563
					K _v	4.04	62.5	93.4	124	154	184	215	242	272	300	---
12 x 6	136.5	5.375	165	6.5	C _v	4.67	94.0	141	187	233	278	324	370	413	457	0.563
					K _v	4.04	81.3	122	162	202	240	280	320	357	395	---
C3 ΔP/P₁ ≤ 0.85																
8 x 6	136.5	5.375	127	5	C _v	4.67	50.0	74.7	99.3	124	149	173	197	221	245	0.563
					K _v	4.04	43.3	64.6	85.9	107	129	150	170	191	212	---
12 x 6	136.5	5.375	165	6.5	C _v	4.67	64.0	96.0	127	160	191	222	254	284	315	0.563
					K _v	4.04	55.4	83.0	110	138	165	192	220	246	272	---
D3 ΔP/P₁ ≤ 0.99																
8 x 6	136.5	5.375	127	5	C _v	4.67	12.7	31.4	55.0	79.7	104	128	152	177	201	0.563
					K _v	4.04	11.0	27.2	47.6	68.9	90.0	111	131	153	174	---
12 x 6	136.5	5.375	165	6.5	C _v	4.67	23.8	53.3	85.0	116	148	180	211	243	273	0.563
					K _v	4.04	20.6	46.1	73.5	100	128	156	183	210	236	---

1. Level D exhibits an equal percentage characteristic for the first 38 mm (1.5 inch) of travel, then linear characteristic.
 2. The first number indicates the body inlet and outlet size. The second number indicates nominal port size.
 3. Valves should not be required to throttle at less than the specified minimum coefficient for an extended period of time. Erosion damage to the valve seats may result.
 4. This column lists X_T factors for cages at 100 % travel.

Table 32. Fisher® EWD and EWD-1; CL900; Quick Opening, Linear, Equal Percentage, and Whisper Trim® I Cages

Quick Opening - Flow Down															Quick Opening Characteristic	
Valve Size, NPS ⁽¹⁾	Port Diameter		Maximum Travel		Flow Coefficient	Valve Opening—Percent of Total Travel										F _L ⁽²⁾
	mm	Inches	mm	Inches		10	20	30	40	50	60	70	80	90	100	
8 x 6	177.8	7	51	2	C _V	83	166	259	355	434	495	558	597	641	670	0.89
					K _V	71.8	144	224	307	375	428	483	516	554	580	---
					X _T	0.501	0.569	0.607	0.633	0.688	0.772	0.787	0.811	0.798	0.809	---
12 x 8	203.2	8	76	3	C _V	149	315	481	640	780	898	1000	1100	1180	1260	0.79
					K _V	129	272	416	554	675	777	865	952	1021	1090	---
					X _T	0.687	0.735	0.727	0.745	0.754	0.784	0.744	0.754	0.711	0.636	---
Linear - Flow Down															Linear Characteristic	
8 x 6	177.8	7	51	2	C _V	46	112	177	243	305	368	421	493	574	644	0.89
					K _V	39.8	96.9	153	210	264	318	364	426	497	557	---
					X _T	0.884	0.746	0.747	0.743	0.755	0.756	0.783	0.788	0.759	0.729	---
12 x 8	203.2	8	76	3	C _V	104	223	348	490	638	781	907	999	1080	1160	0.80
					K _V	90.0	193	301	424	552	676	785	864	934	1003	---
					X _T	0.700	0.694	0.647	0.692	0.697	0.693	0.711	0.741	0.738	0.696	---
Equal Percentage - Flow Down															Equal Percentage Characteristic	
8 x 6	177.8	7	51	2	C _V	12.2	24.4	42.4	67.1	105	167	241	321	405	477	0.92
					K _V	10.6	21.1	36.7	58.0	90.8	144	208	278	350	413	---
					X _T	0.715	0.614	0.526	0.506	0.507	0.529	0.609	0.669	0.704	0.757	---
12 x 8	203.2	8	76	3	C _V	28.4	61.0	112	196	311	481	687	839	992	1090	0.81
					K _V	24.6	52.8	96.9	170	269	416	594	726	858	943	---
					X _T	0.666	0.665	0.667	0.664	0.659	0.666	0.664	0.662	0.663	0.663	---
Whisper Trim I - Flow Up															Linear Characteristic	
8 x 6	177.8	7	51	2	C _V	44.8	104	171	233	302	366	439	492	544	568	---
					K _V	38.8	90.0	148	202	261	317	380	426	471	491	---
					X _T	0.516	0.384	0.342	0.330	0.315	0.308	0.292	0.307	0.309	0.327	---

1. The first number indicates both body inlet and outlet size. The second number indicates nominal port size.
 2. At 100% travel.

Notes: The coefficients shown on this page are also appropriate for the EWT and EWT-1. EWD-1 and EWT-1 are available only in NPS 12x8.

Table 33. Fisher® EWD-1, CL900, Whisper Trim® III Cage

Whisper Trim III - Flow Up																Linear Characteristic	
Valve Size, NPS ⁽¹⁾	Port Diameter		Maximum Travel		Flow Coefficient	Valve Opening—Percent of Total Travel											X _T at Max. Travel
	mm	Inches	mm	Inches		Minimum ⁽²⁾	10	20	30	40	50	60	70	80	90	100	
A1 & A3 $\Delta P/P_1 \leq 0.6$																	
12 x 8	196.8	7.75	152	6	C _v	4.67	88.0	175	264	352	440	528	616	704	792	880	0.563
					K _v	4.04	76.1	151	228	304	381	457	533	609	685	761	---
B1 & B3 $\Delta P/P_1 \leq 0.75$																	
12 x 8	196.8	7.75	152	6	C _v	4.67	57.8	116	173	141	289	347	431	462	520	578	0.563
					K _v	4.04	50.0	100	150	122	250	300	373	400	450	500	---
C1 & C3 $\Delta P/P_1 \leq 0.85$																	
12 x 8	196.8	7.75	152	6	C _v	4.67	40.8	81.5	122	163	204	245	285	326	367	408	0.563
					K _v	4.04	35.3	70.5	106	141	176	212	247	282	317	353	---
D1 & D3 $\Delta P/P_1 \leq 0.99$																	
12 x 8	196.8	7.75	152	6	C _v	3.67	34.8	69.5	104	139	174	209	243	278	313	348	0.563
					K _v	3.17	30.1	60.1	90.0	120	151	181	210	240	271	301	---

1. The first number indicates both inlet and outlet size. The second number indicates nominal port size.
 2. Valve should not be required to throttle at less than the specified minimum coefficient for an extended period of time or erosion damage to the valve seat may result.

Notes: The coefficients shown on this page are also appropriate for the EWT-1.

Table 34. Fisher® EWS, CL150, 300, and 600, Quick Opening and Linear Cages, Flow Up through the Port

Quick Opening																Quick Opening Characteristic	
Valve Size, NPS ⁽¹⁾	Port Diameter		Maximum Travel		Flow Coefficient	Coeffs. for 6mm (0.25 in) Travel ⁽²⁾	Valve Opening—Percent of Total Travel										F _L ⁽³⁾
	mm	Inches	mm	Inches			10	20	30	40	50	60	70	80	90	100	
4 x 2	58.7	2.3125	29	1.125	C _V	29.9	13.7	26.9	42.1	60.0	76.8	90.2	101	110	117	123	0.89
					K _V	0.660	11.9	23.3	36.4	51.9	66.4	78.0	87.4	95.2	101	106	---
					X _T	0.660	0.639	0.663	0.652	0.660	0.705	0.777	0.843	0.868	0.860	0.793	---
6 x 4	111.1	4.375	51	2	C _V	48.1	39.4	85.2	147	208	268	321	355	373	379	382	0.88
					K _V	0.600	34.1	73.7	127	180	232	278	307	323	328	330	---
					X _T	0.600	0.619	0.587	0.591	0.633	0.662	0.682	0.726	0.748	0.770	0.781	---
8 x 4	111.1	4.375	51	2	C _V	51.3	42.1	88.2	149	212	269	314	365	405	437	450	0.85
					K _V	0.585	36.4	76.3	129	183	233	272	316	350	378	389	---
					X _T	0.585	0.578	0.573	0.560	0.579	0.640	0.726	0.733	0.726	0.727	0.704	---
8 x 6	177.8	7	51	2	C _V	97.8	79.3	152	249	346	442	533	606	650	683	714	0.86
					K _V	0.661	68.6	131	215	299	382	461	524	562	591	618	---
					X _T	0.661	0.682	0.671	0.634	0.655	0.663	0.681	0.688	0.709	0.715	0.671	---
12 x 6	177.8	7	51	2	C _V	109	86.1	168	261	359	460	554	641	720	799	874	0.79
					K _V	0.594	74.5	145	226	311	398	479	554	623	691	756	---
					X _T	0.594	0.614	0.563	0.571	0.608	0.630	0.660	0.677	0.706	0.735	0.736	---
10 x 8	203.2	8	76	3	C _V	---	151	313	471	617	748	848	918	956	971	1000	0.93
					K _V	---	131	271	407	534	647	734	794	827	840	865	---
					X _T	---	0.632	0.606	0.625	0.663	0.698	0.751	0.798	0.838	0.864	0.842	---
12 x 8	203.2	8	76	3	C _V	---	157	322	480	632	760	860	957	1030	1080	1110	0.89
					K _V	---	136	279	415	547	657	744	828	891	934	960	---
					X _T	---	0.718	0.716	0.712	0.730	0.789	0.844	0.855	0.873	0.866	0.836	---
Linear																Linear Characteristic	
4 x 2	58.7	2.3125	29	1.125	C _V	---	6.88	13.7	21.5	29.9	39.1	49.0	60.0	72.2	84.5	96.2	0.89
					K _V	---	5.95	11.9	18.6	25.9	33.8	42.4	51.9	62.5	73.1	83.2	---
					X _T	---	0.599	0.662	0.728	0.742	0.745	0.743	0.744	0.761	0.777	0.794	---
6 x 4	111.1	4.375	51	2	C _V	---	26.2	52.5	78.4	105	133	162	197	236	281	320	0.89
					K _V	---	22.7	45.4	67.8	90.8	115	140	170	204	243	277	---
					X _T	---	0.713	0.640	0.661	0.667	0.659	0.666	0.666	0.676	0.690	0.725	---
8 x 4	111.1	4.375	51	2	C _V	---	25.1	51.5	78.1	104	130	157	192	234	281	328	0.89
					K _V	---	21.7	44.5	67.6	90.0	112	136	166	202	243	284	---
					X _T	---	0.610	0.657	0.682	0.688	0.700	0.715	0.716	0.711	0.716	0.729	---
8 x 6	177.8	7	51	2	C _V	---	52.5	116	182	246	311	375	435	495	554	607	0.88
					K _V	---	45.4	100	157	213	269	324	376	428	479	525	---
					X _T	---	0.655	0.678	0.688	0.708	0.726	0.728	0.723	0.729	0.720	0.679	---
12 x 6	177.8	7	51	2	C _V	---	57.4	122	186	248	311	375	441	510	591	675	0.84
					K _V	---	49.7	106	161	215	269	324	381	441	511	584	---
					X _T	---	0.523	0.572	0.612	0.654	0.659	0.683	0.704	0.719	0.723	0.719	---
10 x 8	203.2	8	76	3	C _V	---	106	210	315	427	546	661	766	848	905	958	0.92
					K _V	---	91.7	182	272	369	472	572	663	734	783	829	---
					X _T	---	0.677	0.677	0.708	0.711	0.702	0.705	0.731	0.777	0.831	0.820	---
12 x 8	203.2	8	76	3	C _V	---	119	218	336	447	564	680	795	895	981	1050	0.89
					K _V	---	103	189	291	387	488	588	688	774	849	908	---
					X _T	---	0.678	0.768	0.811	0.791	0.802	0.811	0.809	0.819	0.837	0.836	---

1. The first number indicates both inlet and outlet sizes. The second number indicates nominal port size.
 2. When sizing self-operated regulators, use coefficients listed for 6 mm (0.25 inch) travel.
 3. At 100% travel.

Table 35. Fisher® EWS, CL150, 300, and 600, Equal Percentage Cages, Flow Up through the Port

Equal Percentage														Equal Percentage Characteristic		
Valve Size, NPS ⁽¹⁾	Port Diameter		Maximum Travel		Flow Coefficient	Valve Opening—Percent of Total Travel										F _L ⁽²⁾
	mm	Inches	mm	Inches		10	20	30	40	50	60	70	80	90	100	
4 x 2	58.7	2.3125	29	1.125	C _V	2.40	4.16	5.97	8.37	12.2	17.6	26.3	38.1	52.7	67.5	0.90
					K _V	2.08	3.60	5.16	7.24	10.6	15.2	22.7	33.0	45.6	58.4	---
					X _T	0.751	0.770	0.781	0.776	0.769	0.773	0.732	0.739	0.754	0.777	---
6 x 4	111.1	4.375	51	2	C _V	7.18	12.3	18.2	26.7	39.8	61.0	100	158	217	271	0.88
					K _V	6.21	10.6	15.7	23.1	34.4	52.8	86.5	137	188	234	---
					X _T	0.794	0.778	0.775	0.773	0.773	0.776	0.718	0.687	0.707	0.694	---
8 x 4	111.1	4.375	51	2	C _V	8.37	12.8	20.0	28.5	42.2	64.6	102	156	214	269	0.90
					K _V	7.24	11.1	17.3	24.7	36.5	55.9	88.2	135	185	233	---
					X _T	0.761	0.731	0.716	0.745	0.758	0.724	0.701	0.684	0.709	0.704	---
8 x 6	177.8	7	51	2	C _V	12.0	22.8	36.9	58.8	91.3	149	226	311	397	478	0.92
					K _V	10.4	19.7	31.9	50.9	79.0	129	195	269	343	413	---
					X _T	0.733	0.783	0.874	0.859	0.836	0.791	0.773	0.782	0.755	0.727	---
12 x 6	177.8	7	51	2	C _V	18.6	30.0	43.8	65.7	97.1	153	231	312	395	476	0.88
					K _V	16.1	25.9	37.9	56.8	84.0	132	200	270	342	412	---
					X _T	0.661	0.694	0.824	0.813	0.812	0.802	0.764	0.777	0.774	0.788	---
10 x 8	203.2	8	76	3	C _V	33.9	61.2	97.7	162	269	417	568	705	840	932	0.90
					K _V	29.3	52.9	84.5	140	233	361	491	610	727	806	---
					X _T	0.836	0.867	0.894	0.796	0.744	0.704	0.699	0.712	0.725	0.760	---
12 x 8	203.2	8	76	3	C _V	28.8	58.1	102	175	294	452	654	859	989	1020	0.88
					K _V	24.9	50.3	88.2	151	254	391	566	743	855	882	---
					X _T	0.769	0.832	0.928	0.930	0.797	0.744	0.651	0.581	0.646	0.766	---

1. The first number indicates both body inlet and outlet size. The second number indicates nominal port size.
 2. At 100% travel.

Table 36. Fisher® EWS, CL150, 300, and 600, Whisper Trim® I Cages, Flow Up through the Port

Whisper Trim I															Linear Characteristic	
Valve Size, NPS ⁽¹⁾	Port Diameter		Maximum Travel		Flow Coefficient	Valve Opening—Percent of Total Travel										F _L ⁽²⁾
	mm	Inches	mm	Inches		10	20	30	40	50	60	70	80	90	100	
4 x 2	58.7	2.3125	29	1.125	C _V	14.2	27.7	39.8	51.7	63.8	76.2	88.3	99.9	111	118	---
					K _V	12.3	24.0	34.4	44.7	55.2	65.9	76.4	86.4	96.0	102	---
					X _T	0.321	0.323	0.322	0.320	0.323	0.322	0.324	0.323	0.320	0.322	---
6 x 4	111.1	4.375	51	2	C _V	30.9	71.5	110	150	185	221	252	280	302	325	---
					K _V	26.7	61.8	95	130	160	191	218	242	261	281	---
					X _T	0.520	0.340	0.299	0.290	0.286	0.286	0.298	0.313	0.329	0.331	---
8 x 4	111.1	4.375	51	2	C _V	34.3	75.5	115	153	190	226	261	295	322	343	---
					K _V	29.7	65.3	99	132	164	195	226	255	279	297	---
					X _T	0.486	0.310	0.274	0.263	0.260	0.258	0.262	0.266	0.274	0.279	---
8 x 6	177.8	7	51	2	C _V	42.0	95.5	157	223	282	346	411	474	528	575	---
					K _V	36.3	82.6	136	193	244	299	356	410	457	497	---
					X _T	0.571	0.460	0.386	0.358	0.358	0.345	0.331	0.324	0.334	0.319	---
			102	4	C _V	100	257	360	443	498	531	558	582	604	626	---
					K _V	86.5	222	311	383	431	459	483	503	522	541	---
					X _T	0.308	0.228	0.305	0.351	0.432	0.566	0.652	0.710	0.748	0.744	---
12 x 6	177.8	7	51	2	C _V	49.6	123	193	262	331	401	466	532	592	639	---
					K _V	42.9	106	167	227	286	347	403	460	512	553	---
					X _T	0.572	0.345	0.310	0.296	0.289	0.280	0.282	0.277	0.279	0.274	---
			102	4	C _V	94.0	229	345	450	544	650	765	835	855	940	---
					K _V	81.3	198	298	389	471	562	662	722	740	813	---
					X _T	0.357	0.292	0.336	0.334	0.363	0.384	0.369	0.410	0.490	0.462	---
10 x 8	203.2	8	76	3	C _V	88.1	230	361	469	559	654	739	808	851	881	---
					K _V	76.2	199	312	406	484	566	639	699	736	762	---
					X _T	0.507	0.393	0.348	0.338	0.359	0.379	0.409	0.434	0.469	0.536	---
			102	4	C _V	136	315	471	600	713	802	868	895	894	942	---
					K _V	118	272	407	519	617	694	751	774	773	815	---
					X _T	0.453	0.358	0.347	0.365	0.390	0.433	0.490	0.582	0.690	0.694	---

1. The first number indicates both body inlet and outlet size. The second number indicates nominal port size.
 2. At 100% travel.

Table 37. Fisher® EWS, CL150, 300, and 600, Whisper Trim® III Cage

Whisper Trim III - Flow Up														Linear Characteristic ⁽¹⁾		
Valve Size, NPS ⁽²⁾	Port Diameter		Maximum Travel		Flow Coefficient	Valve Opening—Percent of Total Travel										x _T ⁽⁴⁾
	mm	Inches	mm	Inches		Minimum ⁽³⁾	20	30	40	50	60	70	80	90	100	
A3 ΔP/P1 ≤ 0.6																
8 x 6	136.5	5.375	127	5	C _v	4.00	96.5	157	213	267	323	378	422	452	460	0.727
					K _v	3.46	83.5	136	184	231	279	327	365	391	398	---
12 x 6	136.5	5.375	165	6.5	C _v	4.00	124	192	258	320	383	440	500	554	603	0.766
					K _v	3.46	107	166	223	277	331	381	433	479	522	---
B3 ΔP/P1 ≤ 0.6																
8 x 6	136.5	5.375	127	5	C _v	4.67	72.3	108	143	178	213	248	280	314	347	0.563
					K _v	4.04	62.5	93	124	154	184	215	242	272	300	---
12 x 6	136.5	5.375	165	6.5	C _v	4.67	94.0	141	187	233	278	324	370	413	457	0.563
					K _v	4.04	81.3	122	162	202	240	280	320	357	395	---
C3 ΔP/P1 ≤ 0.6																
8 x 6	136.5	5.375	127	5	C _v	4.67	50.0	74.7	99.3	124	149	173	197	221	245	0.563
					K _v	4.04	43.3	64.6	85.9	107	129	150	170	191	212	---
12 x 6	136.5	5.375	165	6.5	C _v	4.67	64.0	96.0	127	160	191	222	254	284	315	0.563
					K _v	4.04	55.4	83.0	110	138	165	192	220	246	272	---
D3 ΔP/P1 ≤ 0.6																
8 x 6	136.5	5.375	127	5	C _v	4.67	12.7	31.4	55.0	79.7	104	128	152	177	201	0.563
					K _v	4.04	11.0	27.2	47.6	68.9	90.0	111	131	153	174	---
12 x 6	136.5	5.375	165	6.5	C _v	4.67	23.8	53.3	85.0	116	148	180	211	243	273	0.563
					K _v	4.04	20.6	46.1	73.5	100	128	156	183	210	236	---

1. Level D exhibits an equal percentage characteristic for the first 38 mm (1.5 inch) of travel, then linear characteristic.
 2. The first number indicates both body inlet and outlet size. The second number indicates nominal port size.
 3. Valves should not be required to throttle at less than the specified minimum coefficient for an extended period of time. Erosion damage to the valve seats may result.
 4. This column lists X_T factors at 100% travel.

Table 38. Fisher® EWS; CL900; Quick Opening, Linear, and Equal Percentage Cages

Quick Opening - Flow Up															Quick Opening Characteristic	
Valve Size, NPS ⁽¹⁾	Port Diameter		Maximum Travel		Flow Coefficient	Valve Opening—Percent of Total Travel										F _L ⁽²⁾
	mm	Inches	mm	Inches		10	20	30	40	50	60	70	80	90	100	
8 x 6	177.8	7	51	2	C _V	78.3	150	247	343	438	528	600	643	676	706	0.87
					K _V	67.7	130	214	297	379	457	519	556	585	611	---
					X _T	0.760	0.745	0.697	0.715	0.733	0.751	0.758	0.786	0.787	0.747	---
12 x 8	203.8	8	76	3	C _V	157	322	480	632	760	860	957	1030	1080	1110	0.89
					K _V	136	279	415	547	657	744	828	891	934	960	---
					X _T	0.718	0.716	0.712	0.730	0.789	0.844	0.855	0.873	0.866	0.836	---
Linear - Flow Up															Linear Characteristic	
8 x 6	177.8	7	51	2	C _V	51.5	115	181	245	310	374	434	494	553	606	0.89
					K _V	44.5	99	157	212	268	324	375	427	478	524	---
					X _T	0.764	0.775	0.781	0.803	0.830	0.826	0.818	0.821	0.809	0.772	---
12 x 8	203.8	8	76	3	C _V	119	218	336	447	564	680	795	895	981	1050	0.89
					K _V	103	189	291	387	488	588	688	774	849	908	---
					X _T	0.678	0.768	0.811	0.791	0.802	0.811	0.809	0.819	0.837	0.836	---
Equal Percentage - Flow Up															Equal Percentage Characteristic	
8 x 6	177.8	7	51	2	C _V	11.0	21.8	34.9	54.8	86.3	140	212	292	373	447	0.92
					K _V	9.5	18.9	30.2	47.4	74.6	121	183	253	323	387	---
					X _T	0.839	0.823	0.935	0.953	0.897	0.859	0.844	0.855	0.819	0.791	---
12 x 8	203.8	8	76	3	C _V	28.8	58.1	102	175	294	452	654	859	989	1020	0.88
					K _V	24.9	50.3	88	151	254	391	566	743	855	882	---
					X _T	0.769	0.832	0.928	0.930	0.797	0.744	0.651	0.581	0.646	0.766	---

1. The first number indicates both body inlet and outlet size. The second number indicates nominal port size.
 2. At 100% travel.

Table 39. Fisher® EWT, CL600, Cavtrol® III Cage

CL600 - Flow Down																Linear Characteristic	
Valve Size, NPS ⁽¹⁾	Port Diameter		Maximum Travel		Minimum Throttling C _v ⁽²⁾	Flow Coefficient	Valve Opening—Percent of Total Travel										F _L ⁽³⁾
	mm	Inches	mm	Inches			10	20	30	40	50	60	70	80	90	100	
One Stage																	
4 x 2	58.7	2.3125	29	1.125	3.90	C _v	0.52	1.87	5.71	11.7	17.4	23.0	28.9	35.1	41.1	43.6	0.91
						K _v	0.450	1.62	4.94	10.1	15.1	19.9	25.0	30.4	35.6	37.7	---
6 x 4	111.1	4.375	54	2.125	5.20	C _v	2.03	20.3	41.1	61.5	81.5	101	121	140	158	169	0.95
						K _v	1.76	17.6	35.6	53.2	70.5	87.4	105	121	137	146	---
8 x 4	111.1	4.375	54	2.125	5.20	C _v	2.57	21	42	62.6	82.9	103	124	143	161	171	0.95
						K _v	2.22	18.2	36.3	54.1	71.7	89.1	107.3	124	139	148	---
8 x 6	177.8	7	57	2.25	10.0	C _v	4.40	29	63.9	99.9	136	171	205	237	269	293	0.93
						K _v	3.81	25.1	55.3	86.4	118	148	177	205	233	253	---
12 x 6	177.8	7	57	2.25	10.0	C _v	5.49	34.5	71.1	106	143	179	216	250	283	305	0.93
						K _v	4.75	29.8	61.5	91.7	124	155	187	216	245	264	---
12 x 8 ⁽⁴⁾	203.2	8	86	3.375	15.0	C _v	13.6	62.3	117	171	225	278	331	385	438	487	0.90
						K _v	11.8	53.9	101	148	195	240	286	333	379	421	---
12 x 8 ⁽⁵⁾	203.2	8	152	6	15.0	C _v	82.0	163	245	327	408	490	572	653	735	816	0.92
						K _v	70.9	141	212	283	353	424	495	565	636	706	---
Two Stage																	
4 x 2	4736	1.875	51	2	0.92	C _v	0.84	3.19	5.54	7.92	10.3	12.5	15.4	17.3	19.7	22.0	0.98
						K _v	0.73	2.76	4.79	6.85	8.91	10.8	13.3	15.0	17.0	19.0	---
6 x 4	73.0	2.875	102	4	1.90	C _v	3.48	11.0	18.5	26.0	33.4	41.0	48.5	56.0	63.2	71.0	0.98
						K _v	3.01	9.52	16.0	22.5	28.9	35.5	42.0	48.4	54.7	61.4	---
8 x 6	136.5	5.375	127	5	3.00	C _v	10.9	29.4	47.9	66.6	85.1	104	122	140	160	178	0.98
						K _v	9.43	25.4	41.4	57.6	73.6	90.0	106	121	138	154	---
12 x 6	136.5	5.375	152	6	3.00	C _v	14.1	35.6	57.0	78.6	100	121	143	165	186	208	0.98
						K _v	12.2	30.8	49.3	68.0	86.5	105	124	143	161	180	---
12 x 8	177.8	7	152	6	7	C _v	27.7	54.7	81.6	109	137	163	190	218	245	272	0.98
						K _v	24.0	47.3	70.6	94.3	119	141	164	189	212	235	---

1. The first number indicates both body inlet and outlet size. The second number indicates nominal port size.
 2. Valves should not be required to throttle at a C_v less than the specified minimum C_v for an extended period of time. Erosion damage to the valve seats may result.
 3. At 100% travel.

Table 40. Fisher® EWT, CL900, Cavitrol® III Cage

CL900 - Flow Down																Linear Characteristic	
Valve Size, NPS ⁽¹⁾	Port Diameter		Maximum Travel		Minimum Throttling C _v ⁽²⁾	Flow Coefficient	Valve Opening—Percent of Total Travel										F _L ⁽³⁾
	mm	Inches	mm	Inches			10	20	30	40	50	60	70	80	90	100	
One Stage																	
8 x 6	177.8	7	51	2	10.0	C _v	3.96	26.0	51.9	77.9	104	130	156	181	207	236	0.93
						K _v	3.43	22.5	44.9	67.4	90.0	112	135	157	179	204	---
			127	5	10.0	C _v	24.8	79.2	131	183	238	292	344	396	451	495	0.93
						K _v	21.5	68.5	113	158	206	253	298	343	390	428	---
12 x 8 ⁽⁴⁾	8	8	60	3.375	15.0	C _v	13.6	62.3	117	171	225	278	331	385	438	487	0.90
						K _v	11.8	53.9	101	148	195	240	286	333	379	421	---
12 x 8 ⁽⁵⁾	8	8	152	6	15.0	C _v	69.0	138	207	276	345	414	483	552	622	690	0.92
						K _v	59.7	119	179	239	298	358	418	477	538	597	---
Two Stage																	
8 x 6	136.5	5.375	127	5	3.00	C _v	11.8	32.0	52.2	72.5	92.7	113	133	153	174	175	0.98
						K _v	10.2	27.7	45.2	62.7	80.2	97.7	115	132	151	151	---
12 x 8	177.8	7	152	6	7.0	C _v	27.2	54.4	81.6	109	136	163	190	218	245	272	0.98
						K _v	23.5	47.1	70.6	94.3	118	141	164	189	212	235	---

1. The first number indicates both body inlet and outlet size. The second number indicates nominal port size.
 2. Valves should not be required to throttle at a C_v less than the specified minimum C_v for an extended period of time. Erosion damage to the valve seats may result.
 3. At 100% travel.
 4. This construction has an internal cage spacer and load ring.
 5. This construction has a load ring.

Note: All other EWT flow coefficients are identical to the EWD.

EW Valve

Specifications

Valve Body Configurations

See Available Configurations section

Valve Body Sizes

See table 2

End Connection Styles

Flanged: CL150, 300, 600, and 900 raised-face or ring-type joint flanges per ASME B16.5

Buttwelding: Styles per ASME B16.25 schedules that are consistent with

ASME B16.34 are Schedule ■ 40 or ■ 80 for all CL300 and 600 valves, Schedule ■ 80 or ■ XXS for NPS 8x6 CL900 valves, or Schedule ■ 80, ■ 100, or ■ 120 for NPS 12x8 CL900 valves

Maximum Inlet Pressures and Temperatures⁽¹⁾

Consistent with applicable ■ CL300, ■ 600⁽²⁾, or ■ 900 pressure/temperature ratings per ASME B16.34 unless limited as follows:

Valves With All Except Cavitrol III or Whisper Trim III Cages: Where limited by individual pressure/temperature capabilities in figure 9 or 10 or temperature capabilities in table 11, 12, 13, or 20.

Valves With Cavitrol III Cages: Where limited by individual pressure/temperature capabilities in figure 13 or temperature capabilities in table 16 or 20.

Valves With Whisper Trim III Cages: Where limited by individual pressure/temperature capabilities in figure 16, 17, or 18 or temperature capabilities in table 18 or 20.

Maximum Pressure Drops^{(1),(3)}

Same as maximum inlet pressure for specific construction defined above, except where further limited as follows:

Valves With All Except Cavitrol III or Whisper Trim III Cages: See figure 9 or 10.

Valves With Cavitrol III Cages: See figure 13.

Valves With Whisper Trim III Cages: See figure 16, 17, or 18, except where further restricted by the following max $\Delta P/P_1$ ratio — ■ 0.60 for level

A cages, ■ 0.75 for level B cages, ■ 0.85 for level C cages, or ■ 0.99 for level D cages⁽⁴⁾

Shutoff Classifications Per ANSI/FCI 70-2 and IEC 60534-4

See tables 3 and 4

Construction Materials

Valve, Bonnet, and Bonnet Spacer If Used:

■ WCC carbon steel, ■ LCC carbon steel, ■ WC9 chrome moly steel, ■ CF8M (316 SST), ■ other materials upon request

Valve Plug, Cage, and Metal Seating Parts

Valves With All Except Cavitrol III or Whisper Trim III Cages: See table 5 or 14.

Valves With Cavitrol III Cages: See table 15.

Valves With Whisper Trim III Cages: See table 17, 18, or 19.

All Other Parts: See table 20

Material Temperature Capabilities⁽¹⁾

Valve Body/Trim Combinations

Valves With All Except Cavitrol III or Whisper Trim III Cages: See figure 9 or 10 and table 11, 12, or 13.

Valves With Cavitrol III Cages: See figure 13 and table 16.

Valves With Whisper Trim III Cages: See figure 16, 17, or 18 and table 18.

All Other Parts: See table 20

Flow Characteristics

Standard Cages: ■ Quick-opening, ■ linear, or ■ equal percentage

Cavitrol and Whisper Trim Cages: Linear

Flow Directions

Valves with Standard Cages

EWD, EWD-1, EWT, and EWT-1: Normally down⁽⁵⁾.

EWS and EWS-1: Normally up⁽⁶⁾.

Valves with Cavitrol Cages: Always down⁽⁵⁾.

Valves with Whisper Trim III Cages: Always up⁽⁶⁾

Flow Coefficients and Noise Level Prediction

Refer to the section titled Coefficients in this bulletin or Fisher Catalog 12

Port Diameters and Maximum Valve Plug Travels

See table 21

- continued -

Specifications (continued)

Yoke Boss and Stem Diameters

See table 21

Typical Bonnet Styles (see table 23)

■ Plain, ■ style 1 cast extension, ■ style 2 cast extension, ■ ENVIRO-SEAL bellows seal bonnet

Packing Arrangements

■ Standard PTFE, ■ Double PTFE, ■ Graphite, ■ ENVIRO-SEAL PTFE, ■ ENVIRO-SEAL Duplex, ■ ENVIRO-SEAL Graphite ULF, ■ HIGH-SEAL

Approximate Weights

See table 22

Options

■ Lubricator, ■ lubricator/isolating valve, ■ drilled and tapped connection in extension bonnet for leak-off service, ■ valve body drain plug, ■ ENVIRO-SEAL bellows seal bonnet for positive stem sealing of hard-to-handle fluids at temperatures up to 566°C (1000°F), ■ style 3 fabricated extension bonnet made on order to a specific length for cryogenic service, ■ special seismic service bonnet, ■ packings suitable for nuclear service, and ■ forged bonnet for 5 in. (127 mm) yoke boss on NPS 8x6 CL900 valve, ■ Class V shutoff for EWT above 232°C (450°F) using PEEK anti-extrusion rings ■ Class V shutoff for EWD up to 593°C (1100°F) using C-seal trim

1. The pressure/temperature limits in this bulletin and any applicable standard or code limitation should not be exceeded.
 2. Certain bonnet bolting material selections may require a CL600 easy-e valve assembly to be derated. Contact your Emerson Process Management sales office for more information.
 3. Only NPS 12x8 CL900 valve bodies with threaded (-1) seat rings can take full CL900 pressure drops; CL900 valve bodies with clamped (no dash number) seat rings are limited to CL600 pressure drops. Also, there are two different NPS 8x6 CL900 valve bodies, one for use only with Cavitrol III cages and the other for use with all other constructions. An NPS 8x6 CL900 valve body with Cavitrol III cage can take full CL900 pressure drops. For information on other NPS 8x6 constructions that can take full CL900 pressure drops, contact your Emerson Process Management sales office. All other NPS 8x6 constructions are limited to CL600 pressure drops (1440 psid flowing drop) even though installed in a CL900 valve body.
 4. Restriction based on excessive noise if max ΔP/P1 ratio for a given cage level is exceeded.
 5. Down:in through cage and out through seat ring (direction shown in figure 2).
 6. Up:in through seat ring and out through cage as shown in figure 14.

ENVIRO-SEAL Packing System Specifications

Applicable Stem Diameters

■ 19.1 (3/4), ■ 25.4 (1), and ■ 31.8 (1-1/4) diameter valve stems

Maximum Pressure/Temperature Limits⁽¹⁾

To Meet the EPA Fugitive Emission Standard of 100 PPM⁽²⁾.

For ENVIRO-SEAL PTFE and ENVIRO-SEAL Duplex packing systems: full CL300 up to 232°C (450°F)

For ENVIRO-SEAL Graphite ULF packing system: 1500 psig (104 bar) at 316°C (600°F)

Construction Materials

PTFE Packing Systems:

Packing Ring and Lower Wiper: PTFE V-ring⁽³⁾.

Male and Female Adaptor Rings: Carbon-filled PTFE V-ring
Graphite ULF Packing Systems: Graphite rings
Anti-Extrusion Washer: Filled PTFE (not required for graphite packing)
Lantern Ring: S31600 (316 stainless steel) (not required for graphite packing)
Packing Box Flange: S31600
Spring: ■ 17-7PH stainless steel or ■ N06600
Packing Follower: S31600 lined with carbon-filled PTFE
Packing Box Studs: Strain-hardened 316 stainless steel
Packing Box Nuts: 316 stainless steel SA194 Grade 8M

1. Refer to the valve specifications in this bulletin for pressure/temperature limits of valve parts. Do not exceed the pressure/temperature rating of the valve. Do not exceed any applicable code or standard limitation.
 2. The Environmental Protection Agency (EPA) has set a limit of 100 parts per million (ppm) for fugitive emissions from a valve in selected VOC (Volatile Organic Compound) services.
 3. In vacuum service, it is not necessary to reverse the ENVIRO-SEAL PTFE packing rings.

Note

Neither Emerson, Emerson Process Management, nor any of their affiliated entities assumes responsibility for the selection, use, or maintenance of any product. Responsibility for the selection, use, and maintenance of any product remains with the purchaser and end-user.

Cavitrol, easy-e, ENVIRO-SEAL, Whisper Trim, and Fisher are marks owned by one of the companies in the Emerson Process Management business division of Emerson Electric Co. Emerson Process Management, Emerson, and the Emerson logo are trademarks and service marks of Emerson Electric Co. C-seal is a mark owned by Pressure Science, Inc. All other marks are the property of their respective owners. This product may be covered by one or more of the following patents: 5,129,625; 5,131,666; 5,056,757; 5,230,498; and 5,299,812 or under pending patents.

The contents of this publication are presented for informational purposes only, and while every effort has been made to ensure their accuracy, they are not to be construed as warranties or guarantees, express or implied, regarding the products or services described herein or their use or applicability. All sales are governed by our terms and conditions, which are available upon request. We reserve the right to modify or improve the designs or specifications of such products at any time without notice. Neither Emerson, Emerson Process Management, nor any of their affiliated entities assumes responsibility for the selection, use or maintenance of any product. Responsibility for proper selection, use, and maintenance of any product remains solely with the purchaser and end-user.

Emerson Process Management

Marshalltown, Iowa 50158 USA

Sorocaba, 18087 Brazil

Chatham, Kent ME4 4QZ UK

Dubai, United Arab Emirates

Singapore 128461 Singapore

www.Fisher.com

