

**1-2471 SERIES
ECCENTRIC DISC
CONTROL VALVES**



1-2471 SERIES ECCENTRIC DISC CONTROL VALVES

PARCOL 1-2471 series control valves feature a double eccentric disc and an easy-to-be changed PTFE or metal seal ring.

These valves provide flow control with an excellent shutoff against high pressure drops applied in either direction.

Body sizes from 3" through 24" compatible with UNI, DIN, ANSI raised face flanges are available.

Up to DN 1600 available on request.

MAIN FEATURES

BODY

- type: flangeless.
- sizes: 3" through 24" compatible with UNI, DIN, ANSI flanges.
- face-to-face dimensions: according to ISO 5752, medium series.
- rating: UNI PN 10, 16, 25, 40, 64, 100 ANSI 150, 300, 600
see relevant table on next page for the complete availability - Take into account that the max pressure and/or temperature can be affected by bearings and seal ring materials.
- construction materials: see relevant tables - Steel bodies can be cast, wrought or forged. Other special materials are available on request (SA352 LCB, AISI 316L, Hastelloy, Monel, Alloy 20).

DISC

- type: double-eccentric design which minimize the contact of disc with seal ring, reducing wear and torque requirements.
- construction materials: the same as body.
- flow characteristic: linear from 10% through 90% of rate travel.
- rangeability: over 100 - see Cv coefficients table.
- rotation: 90° according to the path shown in fig. 2; 60° for special pneumatic actuators
- flow direction: standard is with flow into the flat side of the disc - The opposite direction is permissible but with reduced performances.
- action: air-to-open and air-to-close with single-acting actuators. To change action only assembling operations are required.

SEAL RING

- construction: PTFE or metal types are available for any sizes and are interchangeable without any change up to 12" included.
- temperature capabilities: PTFE seal ring: max 200 °C.
metal seal ring: max 375 °C
The limits vs Δp are outlined in fig. 4
- shutoff classification: PTFE seal ring: max leakage is according to class V IEC 60534.4 limits - IEC code: VL2
metal seal ring: class IV S1 IEC 60534.4 (20 times better than class IV ANSI B16.104) - IEC code: IV-S1 L2

SHAFT

- construction: made in one piece and pinned sidewise to the disc.
- materials: 17-4-PH, A479 XM 19, AISI 316, AISI 316L

BEARINGS

- construction: PTFE-lined or all-metal bushing.
- temperature capabilities: PTFE-lined bearings may be used up to 250 °C; All-metal bearings may be used up to 375 °C.

PACKING

- seal materials: reinforced PTFE split rings and pure graphite rings.
- design: adjustable by follower and two screws.
- temperature capabilities: graphited PTFE rings: 200 °C; pure graphite: no practical limits.

FIGURE 1 - MINIMUM INSIDE DIAMETER OF FITTING FLANGES

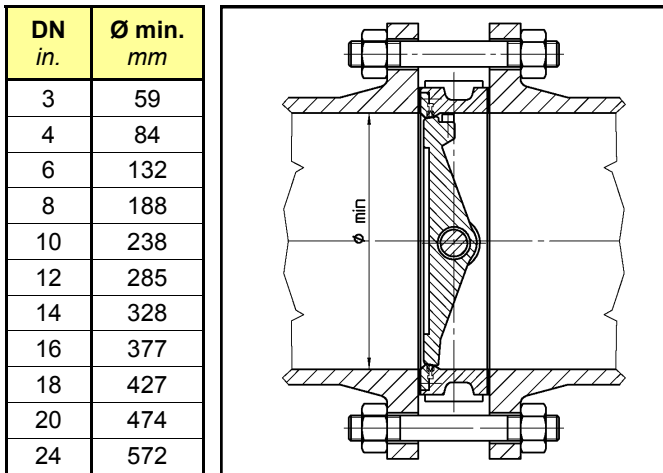

VALVE BODY AND CONNECTIONS AVAILABILITY

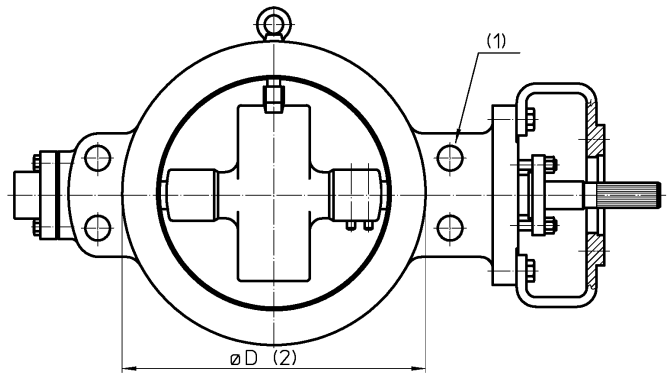

DN in.	ANSI			PN UNI DIN					
	150	300	600	10	16	25	40	64	100
3	X	X	X	X	X	X	X	X	X
4	X	X	X	X	X	X	X	X	X
6	X	X	X	X	X	X	X	X	X ⁽³⁾
8	X	X	X	X	X	X	X	X	X
10	X	X ^(*)		X	X	X	X		
12	X	X ⁽⁴⁾		X	X	X ⁽³⁾	X ⁽³⁾		
14	X	X ^(*)		X	X	X ⁽³⁾	X ⁽³⁾		
16	X	X ^(*)		X	X	X	X ⁽³⁾		
18	X			X ^(*)	X ^(*)				
20	X ^(*)			X ^(*)	X ^(*)				
24	X ^(*)			X ^(*)	X ^(*)				

FIGURE 2 - DISC ROTATION

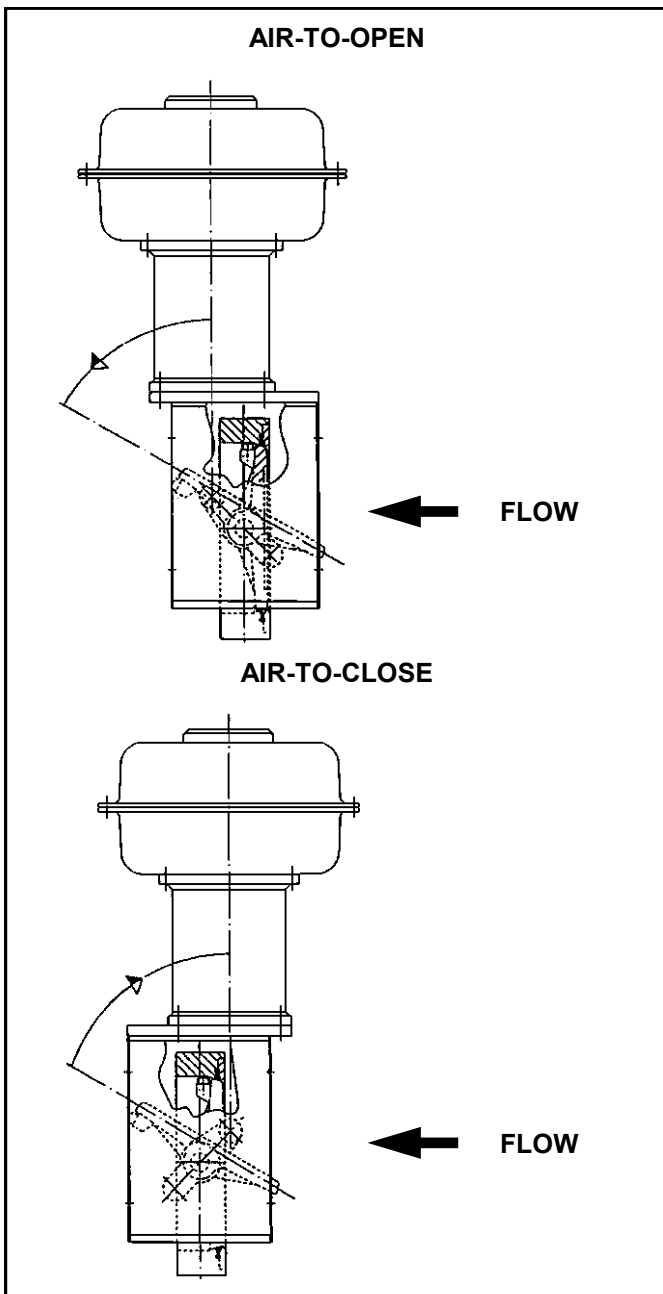

(1) the four holes adjacent to valve shaft pass through the body except where (*) is indicated: in this case holes are ISO coarse threaded (ANSI B1.1 threads available on request) with the correspondence stated on table 3 in overall dimensions page;

(2) UNI, DIN raised faces are available on request as special execution; cast UNI DIN bodies face diameters are unified according to ANSI standard

(3) the four holes adjacent to valve shaft have reduced diameter, see table 2 in overall dimensions page

- LUG version is available on request

WARNING

The use of Parcol butterfly valves to perform closure in dead-end pipe is FORBIDDEN!

MOUNTING

- Check the flow direction outlined on the plate fixed on the body. Be careful the standard flow direction is on opposite shaft side.

- To prevent interference with the travel of the valve disc the connected piping shall have an inside diameter greater than the one shown on relevant table of figure 1.

For further information see the instructions and maintenance book.

FLOW COEFFICIENT C_v ⁽¹⁾

DN in.	DN mm	Cv max 90°	Valve opening ⁽²⁾⁽³⁾									
			5°	10°	20°	30°	40°	50°	60°	70°	80°	
3	75	130	0.8	5.1	17	32	49	67	89	112	127	
4	100	285	1.9	11	38	71	108	147	196	246	279	
6	150	730	4.7	29	97	183	277	377	502	631	715	
8	200	1780	12	65	206	365	546	768	1067	1397	1660	
10	250	3300	22	113	324	527	770	1143	1690	2328	2924	
12	300	5000	33	156	466	756	1110	1654	2459	3447	4407	
14	350	6700	44	189	591	954	1410	2111	3159	4512	5874	
16	400	9100	60	230	756	1216	1810	2725	4106	5983	7935	
18	450	11600	76	258	905	1449	2174	3292	4999	7442	10061	
20	500	14100	93	272	1028	1638	2480	3780	5790	8821	12163	
24	600	21000	138	405	1531	2440	3694	5630	8623	13137	18116	

RECOVERY FACTOR F_L

DN in.	DN mm	F_L 90°	Valve opening									
			5°	10°	20°	30°	40°	50°	60°	70°	80°	
3	75	0.70	0.96	0.94	0.91	0.87	0.83	0.80	0.76	0.73	0.71	
4	100	0.67	0.96	0.94	0.90	0.85	0.81	0.77	0.73	0.69	0.67	
6	150	0.65	0.96	0.94	0.89	0.84	0.80	0.75	0.71	0.67	0.65	
8	200	0.59	0.95	0.93	0.88	0.83	0.78	0.73	0.68	0.63	0.60	
10	250	0.56	0.95	0.93	0.88	0.84	0.80	0.74	0.68	0.62	0.58	
12	300	0.52	0.95	0.93	0.87	0.82	0.77	0.71	0.65	0.59	0.54	
14	350	0.52	0.95	0.93	0.87	0.83	0.79	0.73	0.66	0.60	0.55	
16	400	0.52	0.95	0.93	0.88	0.84	0.79	0.73	0.67	0.60	0.55	
18	450	0.52	0.95	0.94	0.88	0.84	0.80	0.74	0.67	0.60	0.55	
20	500	0.53	0.95	0.94	0.89	0.85	0.81	0.75	0.69	0.61	0.55	
24	600	0.52	0.95	0.94	0.89	0.85	0.81	0.75	0.68	0.61	0.55	

COEFFICIENT OF INCIPIENT CAVITATION x_{Fz} ⁽⁴⁾

DN in.	DN mm	x_{Fz} 90°	Valve opening									
			5°	10°	20°	30°	40°	50°	60°	70°	80°	
3	75	0.35	0.87	0.83	0.74	0.65	0.57	0.50	0.44	0.38	0.35	
4	100	0.29	0.86	0.82	0.71	0.61	0.52	0.45	0.38	0.33	0.30	
6	150	0.26	0.85	0.80	0.69	0.58	0.49	0.42	0.35	0.30	0.27	
8	200	0.20	0.84	0.78	0.66	0.55	0.46	0.38	0.31	0.25	0.21	
10	250	0.17	0.84	0.77	0.66	0.57	0.49	0.39	0.30	0.23	0.19	
12	300	0.13	0.83	0.76	0.62	0.53	0.44	0.35	0.26	0.19	0.15	
14	350	0.14	0.83	0.77	0.64	0.55	0.46	0.37	0.28	0.20	0.16	
16	400	0.14	0.83	0.78	0.64	0.56	0.47	0.38	0.28	0.20	0.16	
18	450	0.14	0.83	0.78	0.65	0.57	0.49	0.39	0.29	0.21	0.16	
20	500	0.14	0.82	0.79	0.67	0.59	0.51	0.41	0.31	0.22	0.16	
24	600	0.14	0.82	0.79	0.66	0.59	0.50	0.40	0.30	0.22	0.16	

DIFFERENTIAL PRESSURE RATIO FACTOR x_T

DN in.	DN mm	x_T 90°	x_T 10°
3	75	0.32	0.82
4	100	0.29	0.82
6	150	0.27	0.81
8	200	0.23	0.80
10	250	0.20	0.80
12	300	0.17	0.79
14	350	0.18	0.80
16	400	0.18	0.80
18	450	0.18	0.81
20	500	0.18	0.82
24	600	0.18	0.82

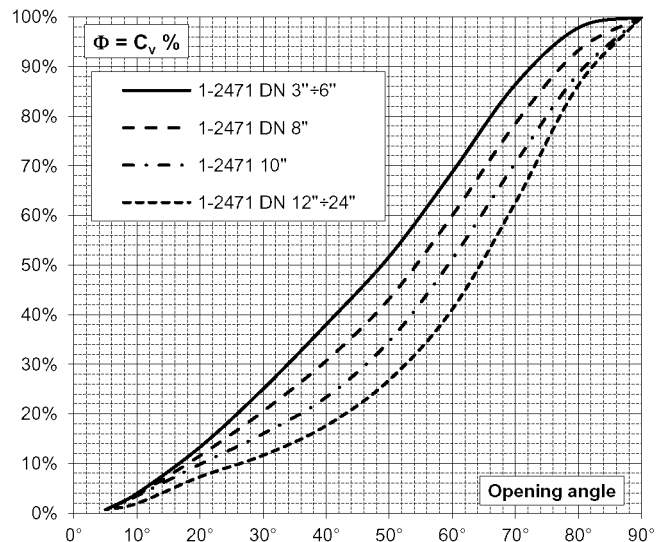

(1) C_v are expressed in U.S. gallons/min. of water with $\Delta p=1$ psi
 (2) Rangeability can be calculated as $C_v \text{ max}/C_v \text{ 5°}$
 (3) Tolerance according to IEC 60534-2-4
 (4) IEC 60534-8-4

FIGURE 3 - FLOW CHARACTERISTICS

1-2471 SERIES VALVE ASSEMBLY

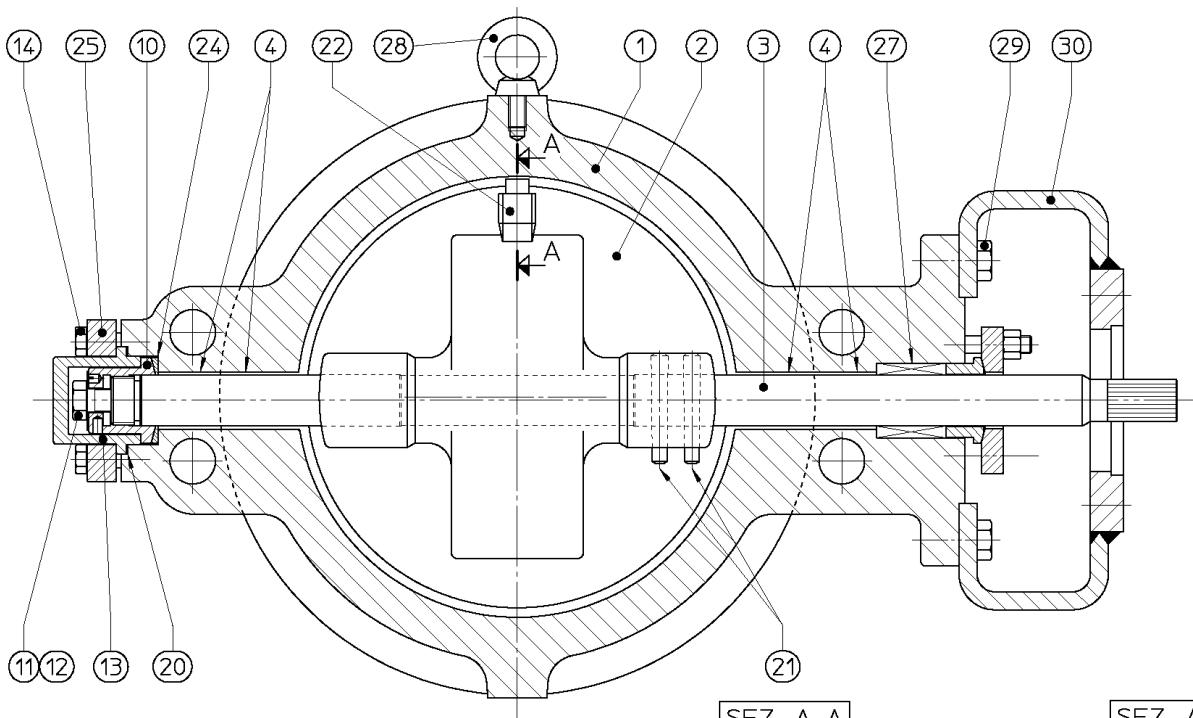

SEZ. A-A

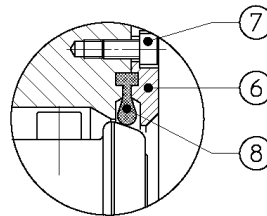

PTFE SEAL RING

SEZ. A-A

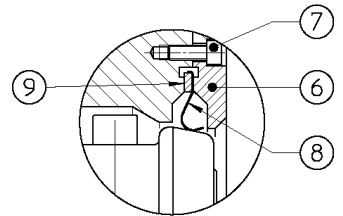

METALLIC SEAL RING FOR DN ≤ 12"

SEZ. A-A

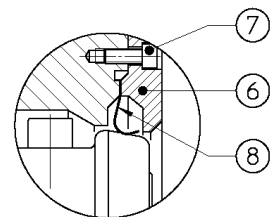

METALLIC SEAL RING FOR DN > 12"

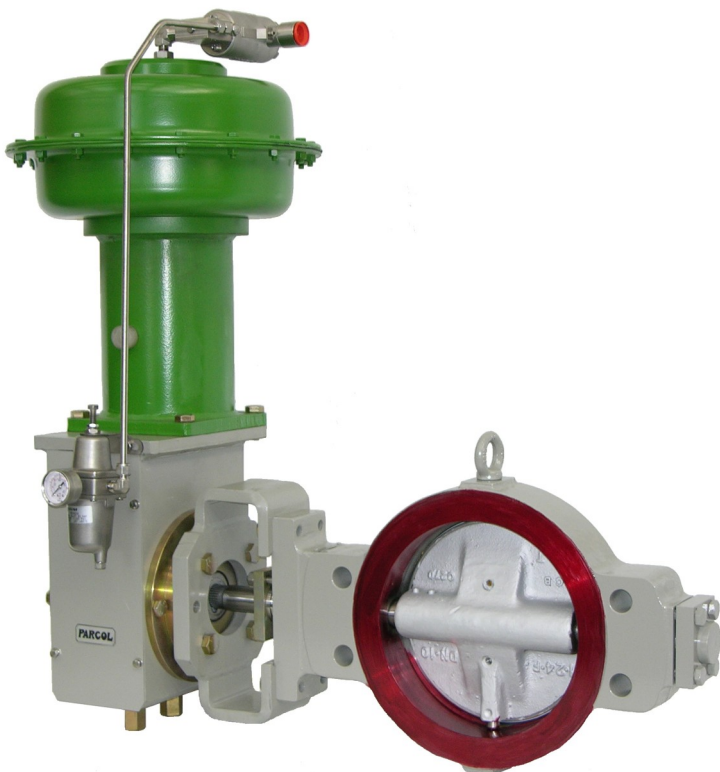

1-2471 SERIES VALVE DN 10" WITH 1-X-271 SERIES PNEUMATIC DIAPHRAGM ACTUATOR

ITEM	PART NAME	ITEM	PART NAME
1	BODY	18	STUD
2	DISC	19	NUT
3	SHAFT	20	GASKET
4	BEARING	21	PIN
6	STOP RING	22	SCREW
7	SCREW	23	BUSHING
8	SEAL RING	24	ANTIFRICTION RING
9	SUPPORT RING	25	FLANGE
10	ADJUSTING RING	27	PACKING
11	SCREW	28	EYE BOLT
12	LOCK WASHER	29	SCREW
13	COVER	30	SUPPORT
14	SCREW	31	EXTENSION
15	PACKING RING	32	SCREW
16	PACKING FOLLOWER	33	GASKET
17	PACKING FLANGE	34	BUSHING

1-2471 SERIES LUG VERSION ASSEMBLY

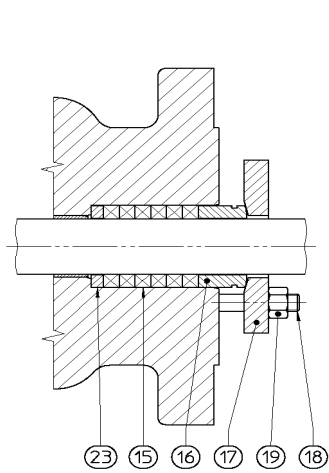
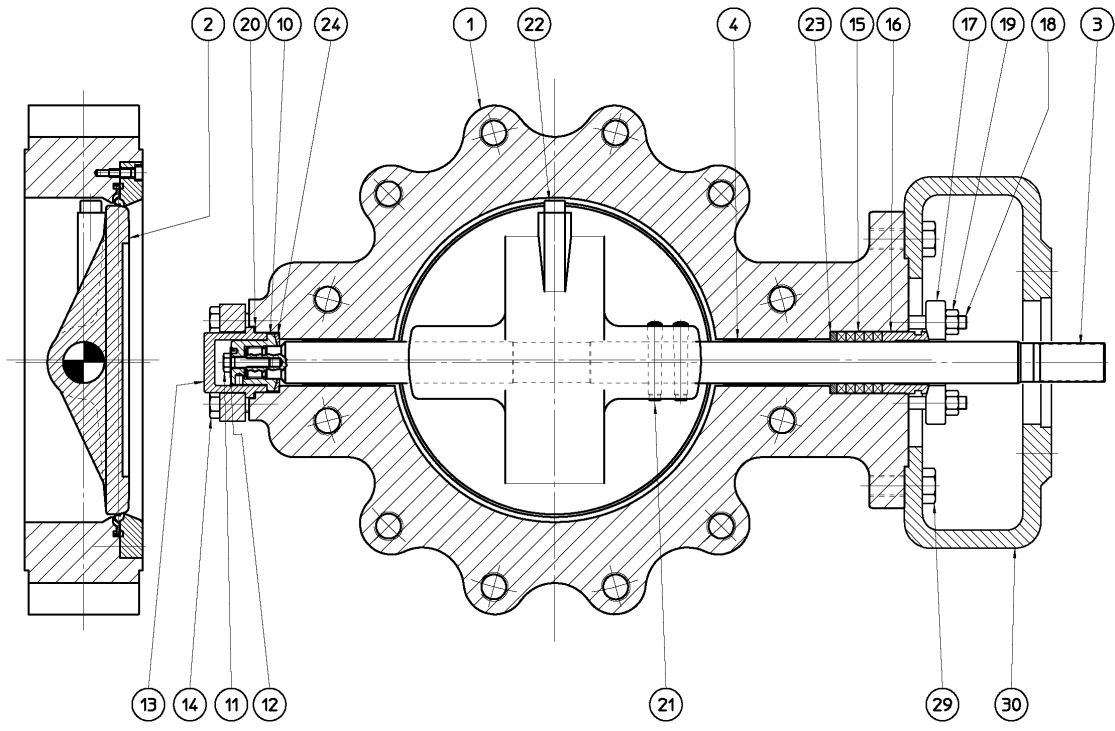

REINFORCED PTFE

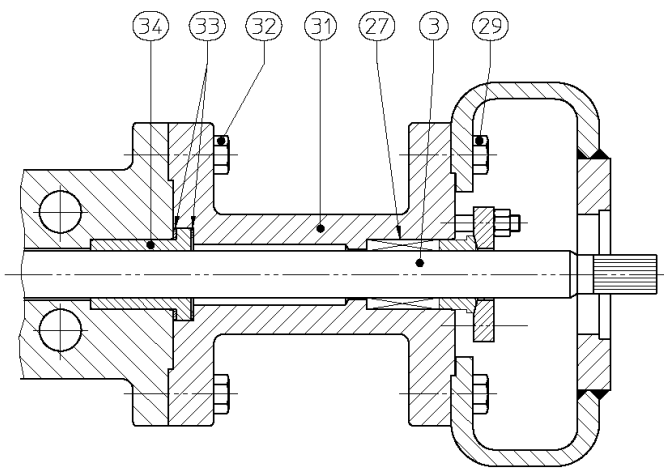

LOW TEMPERATURE CONSTRUCTION

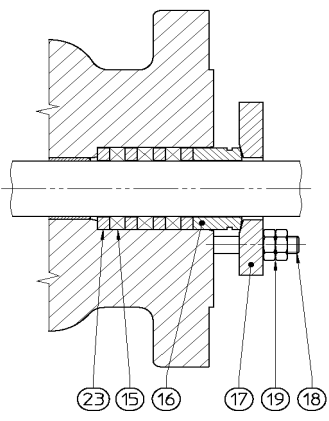

PURE GRAPHITE

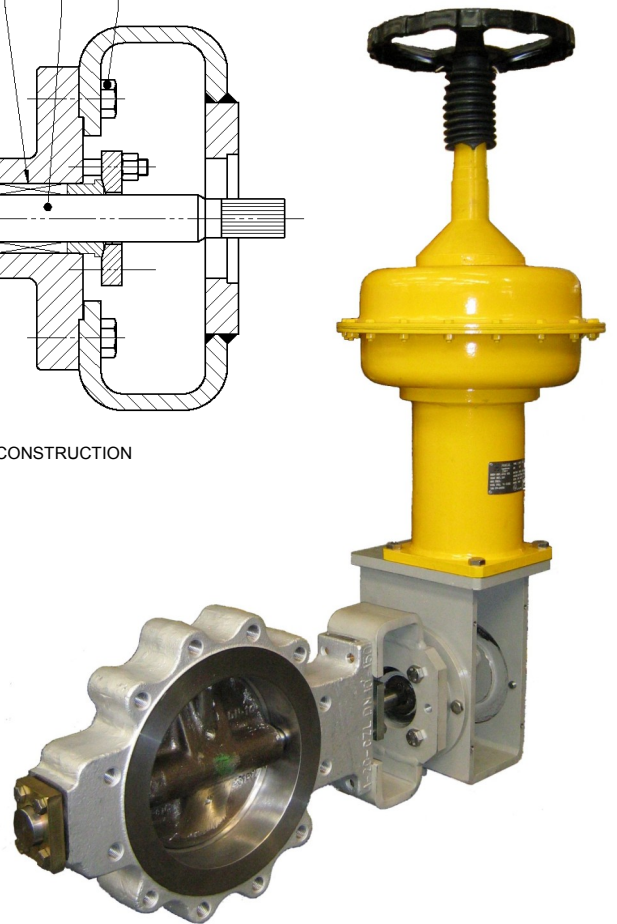

1-2471 SERIES VALVE DN 10" LUG WITH 1-X-271 SERIES PNEUMATIC DIAPHRAGM ACTUATOR PROVIDED WITH TOP-DRIVEN HANDWHEEL (OPTIONAL)

MATERIALS OF CONSTRUCTION

ITEM	PART NAME	BASIC CLASS					NACE (MR0175 - MR0103)				
		A	B	G	H	K	(A)	(G)			
1	BODY	A216 WCB / A 105		AISI 316	AISI 316L	ASTM A890/A890M 4A		A 216 WCB / A105 22HRC max	AISI 316 22HRC max		
2	DISC	A 216 WCB / A 105	AISI 316		AISI 316L	ASTM A890/A890M 4A		A 216 WCB / A105 22HRC max	AISI 316 22HRC max		
3	SHAFT	SEE SUB-CLASS TABLE									
4	BEARING	SEE SUB-CLASS TABLE									
6	STOP RING	A 105	AISI 316	AISI 316L	UNS S31803 (SAF 2205)		A 105 22HRC max	AISI 316 22HRC max			
7	SCREW	AISI 316									
8	SEAL RING	SEE SUB-CLASS TABLE									
9	SUPPORT RING	SEE SUB-CLASS TABLE									
10	ADJUSTING RING	S 21800									
11	SCREW	AISI 304		AISI 316	MONEL 400		AISI 304				
12	LOCK WASHER	AISI 304			AISI 316L		AISI 304				
13	COVER	A 105	AISI 316	AISI 316L		A 105 22HRC max	AISI 316 22HRC max				
14	SCREW	AISI 304			AISI 316L		AISI 304				
20	GASKET	INORGANIC COMPOUND T ≤ 300 °C - ARMOURED GRAPHITE T > 300 °C									
21	PIN	MONEL K500									
22	SCREW	AISI 316			MONEL K500		AISI 316 22HRC max				
24	ANTIFRICTION RING	AISI 316		AISI 316L	BSZN 5-BRONZE		AISI 316 22HRC max				
25	FLANGE	A 105			AISI 316		A 105				
27	PACKING	SEE PACKING TABLE									
28	EYE BOLT	CARBON STEEL									
29	SCREW	8.8 UNI 3740		AISI 304		8.8 UNI 3740		AISI 304			
30	SUPPORT	CARBON STEEL									
31	EXTENSION										
32	SCREW									AISI 316	
33	GASKET									AISI 304	
34	BUSHING									AISI 321 + GRAPHITE	
		S 21.800									

ITEM	PART NAME	SUB-CLASS							
		01	02	04	06	07	08	09	14
3	SHAFT	ASTM A 564-630 H900 (ASTM A 564-630 H 1150M) ⁽²⁾			AISI 316 (22HRC max) ⁽²⁾	XM 19 (35HRC max) ⁽²⁾	AISI 316L (22HRC max) ⁽²⁾	UNS S31803 (SAF 2205) (25HRC max) ⁽²⁾	XM 19 (35HRC max) ⁽²⁾
4	BEARING	CARBON STEEL + BRONZE + PTFE	ASTM B 148-955 (grade D)	AISI 316L + PTFE FIBRES ⁽¹⁾			INCONEL 625 + PTFE FIBRES ⁽¹⁾		AISI 316L + PTFE FIBRES ⁽¹⁾
8	SEAL RING	PTFE	AISI 304L	PTFE					AISI 304L
9	SUPPORT RING			AISI 304					AISI 304
				SILVER-PLATED					SILVER-PLATED

ITEM	PART NAME	PACKING TYPE	SUB-CLASS		
			A-B	G	H-K
15	PACKING RING	TFK GRF	Reinforced PTFE GRAPHITE		
16	PACKING FOLLOWER	TFK - GRF	AISI 316		AISI 316L
17	PACKING FLANGE		CARBON STEEL	AISI 316	
18	STUD		AISI 304		
19	NUT		AISI 304		
23	SPACER RING	TFK GRF	25% Glass loaded PTFE AISI 316		AISI 316L

SELECTION GUIDE			
BASIC CLASS	SUB-CLASS	TEMPERATURE	SERVICE
A	01	-29 °C ± 200 °C	NOT CORROSIVE
	02	-29 °C ± 375 °C	NOT CORROSIVE T > 200 °C
B	01	-29 °C ± 200 °C	NOT CORROSIVE
	02	-29 °C ± 250 °C	NOT CORROSIVE T > 200 °C
G	02	-29 °C ± 375 °C	CORROSIVE T > 200 °C
	04	-29 °C ± 200 °C	CORROSIVE
	06	-50 °C ± 200 °C	CORROSIVE (NACE)
	07	-50 °C ± 200 °C	CORROSIVE FOR HIGH Δp (NACE)
	14	-100 °C ± -51 °C	CORROSIVE FOR HIGH Δp, LOW TEMPERATURE, IV - IV S1 SEAL CLASS (NACE)
H	08	-29 °C ± 200 °C	CORROSIVE (NACE)
K	09	-29 °C ± 200 °C	SEAWATER (BRINE) NOT SUITABLE FOR COPPER FREE SERVICE

⁽¹⁾ Not suitable for hydrochloric acid. For strong solvents the compatibility must be checked with bushing manufacturer.

⁽²⁾ For NACE

MAXIMUM DIFFERENTIAL PRESSURE ACROSS THE VALVE Δp - bar

DN in.	60° OPEN VALVE CLASS										
	A01	A02	B01	B02	G02	G04	G06	G07	G14	H08	K09
3	40.0	25.0	40.0	25.0	25.0	40.0	38.4	40.0	40.0	30.9	30.9
4	33.4	25.0	33.4	25.0	25.0	33.4	33.4	33.4	33.4	29.2	29.2
6	32.2	25.0	32.2	25.0	25.0	32.2	10.4	32.2	32.2	8.4	8.4
8	21.7	25.0	21.7	25.0	25.0	21.7	13.3	21.7	21.7	10.7	10.7
10	13.5	16.0	13.5	16.0	16.0	13.5	5.2	13.5	13.5	4.2	4.2
12	11.4	12.3	11.4	12.3	12.3	11.4	3.6	11.4	11.4	2.9	2.9
14	8.1	8.1	8.1	8.1	8.1	8.1	2.3	8.1	8.1	1.9	1.9
16	5.3	5.3	5.3	5.3	5.3	5.3	1.5	5.3	5.3	1.2	1.2
18	9.4	11.0	9.4	11.0	11.0	9.4	3.2	9.4	9.4	2.6	2.6
20	8.1	8.1	8.1	8.1	8.1	8.1	2.3	8.1	8.1	1.9	1.9
24	4.6	4.6	4.6	4.6	4.6	4.6	1.3	4.6	4.6	1.1	1.1

DN in. / ACTUATOR	60° OPEN VALVE - with actuator CLASS										
	A01	A02	B01	B02	G02	G04	G06	G07	G14	H08	K09
3 / D25	40.0	25.0	40.0	25.0	25.0	40.0	38.4	40.0	40.0	30.9	30.9
4 / D33	33.4	25.0	33.4	25.0	25.0	33.4	33.4	33.4	33.4	29.2	29.2
6 / D33	20.6	20.6	20.6	20.6	20.6	20.6	10.4	20.6	20.6	8.4	8.4
8 / D39	9.1	9.1	9.1	9.1	9.1	9.1	13.3	9.1	9.1	10.7	10.7
10 / D39	3.6	3.6	3.6	3.6	3.6	3.6	5.2	3.6	3.6	4.2	4.2
12 / D46	2.8	2.8	2.8	2.8	2.8	2.8	3.6	2.8	2.8	2.9	2.9
14 / D46	1.8	1.8	1.8	1.8	1.8	1.8	2.3	1.8	1.8	1.9	1.9
16 / D46	1.2	1.2	1.2	1.2	1.2	1.2	1.5	1.2	1.2	1.2	1.2
18 / D63	1.8	1.8	1.8	1.8	1.8	1.8	3.2	1.8	1.8	1.8	1.8
20 / D63	1.4	1.4	1.4	1.4	1.4	1.4	2.3	1.4	1.4	1.4	1.4
24 / D63	0.8	0.8	0.8	0.8	0.8	0.8	1.3	0.8	0.8	0.8	0.8

DN in.	CLOSED VALVE CLASS										
	A01	A02	B01	B02	G02	G04	G06	G07	G14	H08	K09
3	40.0	25.0	40.0	25.0	25.0	40.0	31.8	40.0	40.0	30.8	30.8
4	33.4	25.0	33.4	25.0	25.0	33.4	22.6	33.4	33.4	21.0	21.0
6	21.4	21.4	21.4	21.4	21.4	21.4	9.9	21.4	21.4	8.4	8.4
8	21.7	25.0	21.7	25.0	25.0	21.7	18.6	21.7	21.7	16.1	16.1
10	13.5	16.0	13.5	16.0	16.0	13.5	12.7	13.5	13.5	10.6	10.6
12	11.4	13.5	11.4	13.5	13.5	11.4	11.4	11.4	11.4	10.2	10.2
14	11.1	13.1	11.1	13.1	13.1	11.1	8.9	11.1	11.1	7.0	7.0
16	8.4	9.9	8.4	9.9	9.9	8.4	6.6	8.4	8.4	5.0	5.0
18	9.4	11.1	9.4	11.1	11.1	9.4	9.4	9.4	9.4	11.1	11.1
20	10.1	11.9	10.1	11.9	11.9	10.1	10.1	10.1	10.1	10.2	10.2
24	9.7	11.5	9.7	11.5	11.5	9.7	8.1	9.7	9.7	6.2	6.2

DN in. / ACTUATOR	CLOSED VALVE - with actuator CLASS										
	A01	A02	B01	B02	G02	G04	G06	G07	G14	H08	K09
3 - D25	36.6	25.0	36.6	25.0	25.0	36.6	31.8	36.6	36.6	30.8	30.8
4 - D33	30.4	25.0	30.4	25.0	25.0	30.4	22.6	30.4	30.4	21.0	21.0
6 - D33	16.5	16.5	16.5	16.5	16.5	16.5	9.9	16.5	16.5	8.4	8.4
8 - D39	15.4	15.4	15.4	15.4	15.4	15.4	18.6	15.4	15.4	16.1	16.1
10 - D39	9.9	9.9	9.9	9.9	9.9	9.9	12.7	9.9	9.9	10.6	10.6
12 - D46	11.0	11.0	11.0	11.0	11.0	11.0	11.4	11.0	11.0	10.2	10.2
14 - D46	8.5	8.5	8.5	8.5	8.5	8.5	8.9	8.5	8.5	7.0	7.0
16 - D46	5.5	5.5	5.5	5.5	5.5	5.5	6.6	5.5	5.5	5.0	5.0
18 - D63	9.4	10.3	9.4	10.3	10.3	9.4	9.4	9.4	9.4	11.1	11.1
20 - D63	7.6	7.6	7.6	7.6	7.6	7.6	10.1	7.6	7.6	10.2	10.2
24 - D63	4.3	4.3	4.3	4.3	4.3	4.3	8.1	4.3	4.3	6.2	6.2

Listed values are applicable up to 100 °C. Over this temperature limit Δp values must be reduced according to materials of construction limitations.

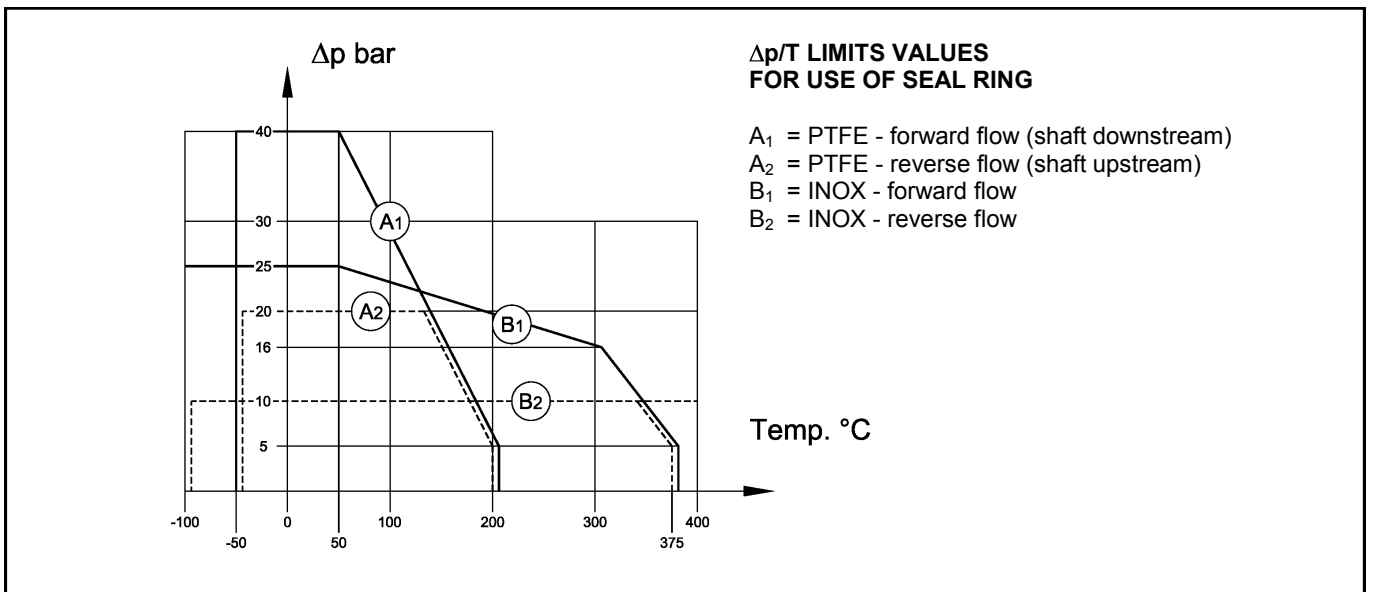
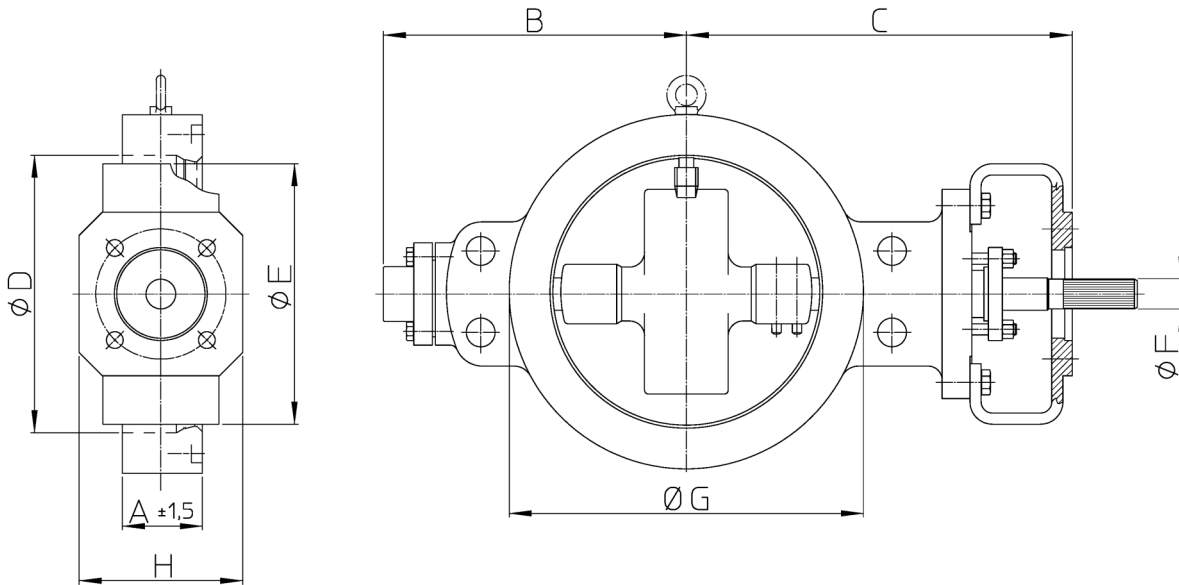

FIGURE 4

OVERALL DIMENSIONS (mm) AND MASSES (kg)



DN		A	B	C	D	E	F	G ⁽¹⁾	H	MASS ⁽²⁾
in.	mm									
3	80	49	137	215	80	78	16	127	90	26
4	100	56	152	246	102	100	19.05	157	126	38
6	150	70	217	300	150	146	25.4	216	126	52
8	200	70	246	357	200	196	31.75	270	176	63
10	250	76	270	382	250	248	31.75	324	176	73
12	300	83	315	415	300	297	34.92	381	176	100
14	350	92	332	432	343	339	41.27	413	176	124
16	400	102	357	457	392	392	41.27	470	176	144
18	450	114	410	539	446	442	50.8	533	212	200
20	500	127	435	579	492	489	60	584	212	240
24	600	154	523	656	592	590	70	692	212	296

TABLE 1 - OVERALL DIMENSIONS AND MASSES

DN		RATING	std holes dia.	red. holes dia.
in.	mm			
6	150	PN 100	33	31
12	300	ANSI 300	32	31
12	300	PN 25	30	28
12	300	PN 40	33	31
14	350	PN 25	33	31
14	350	PN 40	36	34.5
16	400	PN 40	39	38

TABLE 2 - HOLE DIAMETERS

ANSI B1.1 8 UN dia.	ISO dia.
1"	M27
1.1/8"	M30
1.1/4"	M33

TABLE 3 - HOLE THREADING CORRESPONDENCE

⁽¹⁾ If requested, forged bodies are available with UNI, DIN raised faces

⁽²⁾ Without actuator