

工程案例
Engineering case



氟化工
Fluorine chemical



聚酯工程
Polyester engineering



高分子工程
Polymer engineering



新能源
New energy

About the application

关于应用



金波智造
JINBO MANUFACTURING

Bellows globe valve 波纹管截止阀



- ▶ 产品优点: 扭矩小、启闭迅速、密封性能可靠
- ▶ 国标公称通径: DN10—DN600
- ▶ 公称压力: PN16—PN100
- ▶ 美标公称通径: 1/2"—16"
- ▶ 公称压力: 150Lb—600Lb
- ▶ 适用介质: 导热油、蒸气、氯气等

- ▶ Advantages of products: small torque, rapid opening and closing, reliable sealing performance
- ▶ DN: DN10—DN600
- ▶ PN: PN16—PN100
- ▶ NPS: 1/2"—16"
- ▶ CLASS: 150Lb—600Lb
- ▶ Use medium: heat conduction oil, steam, chlorine gas, etc





Bellows gate valve 波纹管闸阀

- ▶ 产品优点: 流量大、流阻小、启闭轻松
- ▶ 国标公称通径: DN10—DN800
- ▶ 公称压力: PN16—PN100
- ▶ 美标公称通径: 1/2"—32"
- ▶ 公称压力: 150Lb—600Lb
- ▶ 适用介质: 导热油、蒸气、氯气等

- ▶ Product advantages: large flow, small flow resistance, light up
- ▶ DN: DN10—DN800
- ▶ PN: PN16—PN100
- ▶ NPS: 1/2"—32"
- ▶ CLASS: 150Lb—600Lb
- ▶ Use medium: heat conduction oil, steam, chlorine gas, etc





订货指南 Order guide	01

WJ41H-16/25波纹管截止阀 Bellows seal globe valve	02

WJ41H-40波纹管截止阀 Bellows seal globe valve	03

WJ61H-25波纹管截止阀 Bellows seal globe valve	04

WJ61H-25波纹管截止阀 Bellows seal globe valve	05

WJ41H-150Lb波纹管截止阀 Bellows seal globe valve	06

WJ41H-300Lb波纹管截止阀 Bellows seal globe valve	07

WJ41H-600Lb波纹管截止阀 Bellows seal globe valve	08

WJ61H-150/300Lb波纹管截止阀 Bellows seal globe valve	09

WZ41H-16/25波纹管闸阀 Bellows seal gate valve	10

WZ41H-40波纹管闸阀 Bellows seal gate valve	11

WZ61H-25波纹管闸阀 Bellows seal gate valve	12

WZ41H-150Lb波纹管闸阀 Bellows seal gate valve	13

WZ41H-300Lb波纹管闸阀 Bellows seal gate valve	14

WZ41H-600Lb波纹管闸阀 Bellows seal gate valve	15

WZ61H-150/300Lb波纹管闸阀 Bellows seal gate valve	16

质量保证和售后服务承诺 Quality assurance and after-sales service commitment	17

订货指南 Order Guide

◆客户须知

1. 样本为标准波纹管阀门，如有特殊需求，应在订货时说明。
2. 型号、口径、压力、连接方式和材质。
3. 阀门连接端执行标准（承插焊、对接焊、法兰等不同形式连接端）。
4. 结构长度执行标准。
5. 对焊接/承插焊连接（BW/SW）必须在订货合同中注明管号。

◆ Ordering instructions

1. The sample is standard bellows valve. If there is a special requirement, it should be stated in the order.
2. Type, caliber, pressure, connection mode and material.
3. The valve connection end (socket welding, butt welding, flange, etc.).
4. Standard for the implementation of structural length.
5. The welding joint/socket welding connection (BW/SW) must be noted in the order contract.

WJ41H-16/25波纹管截止阀

Bellows Globe valve

设计制造标准：GB/T12235
 连接法兰标准：HG/T20592
 结构长度标准：GB/T12221
 波纹管标准：MSS SP-117
 检验与试验标准：GB/T26480
 Design and manufacturing standard: GB/T12235
 Flange dimension standard: HG/T20592
 Structure length standard: GB/T12221
 Bellows standard: MSS sp-117
 Test and test standard: GB/T26480

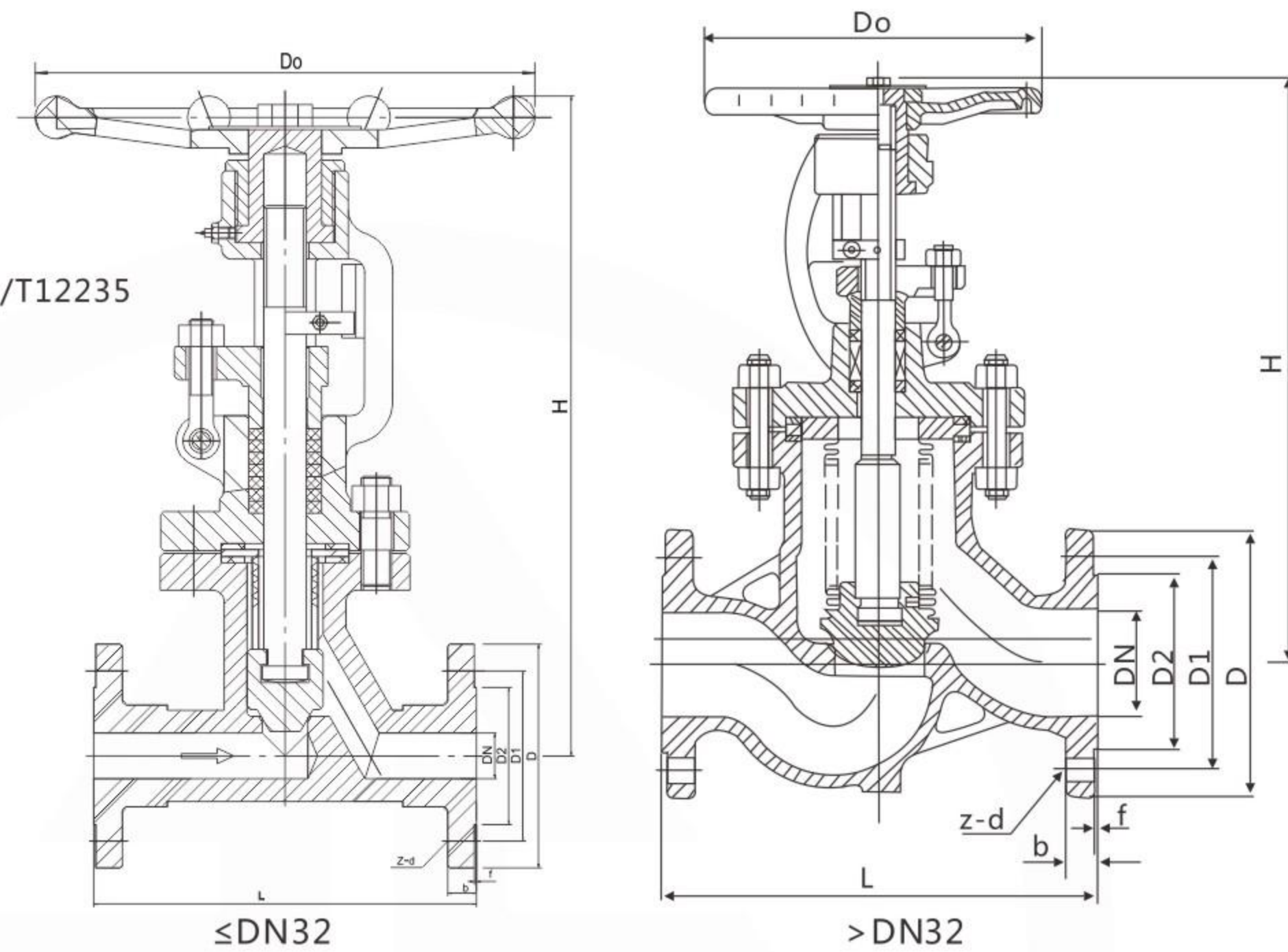

◆ 主要尺寸及重量

公称 通径 DN	尺寸(mm)													
	L	D	D1	D2	b	f	H	Do	Z-d					
10	130	90	60	40	16	16	2	220	120	4-14				
15	130	95	65	45	16	16	2	220	120	4-14				
20	150	105	75	58	18	18	2	220	120	4-14				
25	160	115	85	68	18	18	2	237	140	4-14				
32	180	140	100	78	18	18	2	265	180	4-18				
40	200	150	110	88	18	18	2	295	200	4-18				
50	230	165	125	102	18	20	2	313	220	4-18				
65	290	185	145	122	18	22	2	352	260	8-18	8-18			
80	310	200	160	138	20	24	2	385	280	8-18	8-18			
100	350	220	235	180	190	158	162	20	24	2	455	310	8-18	8-22
125	400	250	270	210	220	188	188	22	26	2	490	400	8-18	8-26
150	480	285	300	240	250	212	218	22	28	2	570	450	8-22	8-26
200	600	340	360	295	310	268	278	24	30	2	700	500	12-22	12-26
250	622	405	425	355	370	320	335	26	32	2	850	580	12-26	12-30
300	711	460	485	410	430	378	395	28	34	2	1020	580	12-26	16-30
350	850	520	555	470	490	428	450	30	38	2	1180	750	16-26	16-33
400	864	580	620	525	550	490	505	32	40	2	1250	810	16-30	16-36
450	978	640	670	585	600	550	555	40	46	2	1900	850	20-30	20-36
500	1016	715	730	650	660	610	615	44	48	2	2100	900	20-33	20-36
600	1295	840	845	770	770	725	720	54	58	2	2300	1000	20-36	20-39

注：说明表格每栏由供一组数据均为1.6MPa、2.5MPa均相同数据。前者为1.6MPa，后者为2.5MPa的。

WJ41H-40波纹管截止阀

Bellows Globe valve

设计制造标准：GB/T12235
 连接法兰标准：HG/T20592
 结构长度标准：GB/T12221
 波纹管标准：MSS SP-117
 检验与试验标准：GB/T26480
 Design and manufacturing standard: GB/T12235
 Flange dimension standard: HG/T20592
 Structure length standard: GB/T12221
 Bellows standard: MSS sp-117
 Test and test standard: GB/T26480

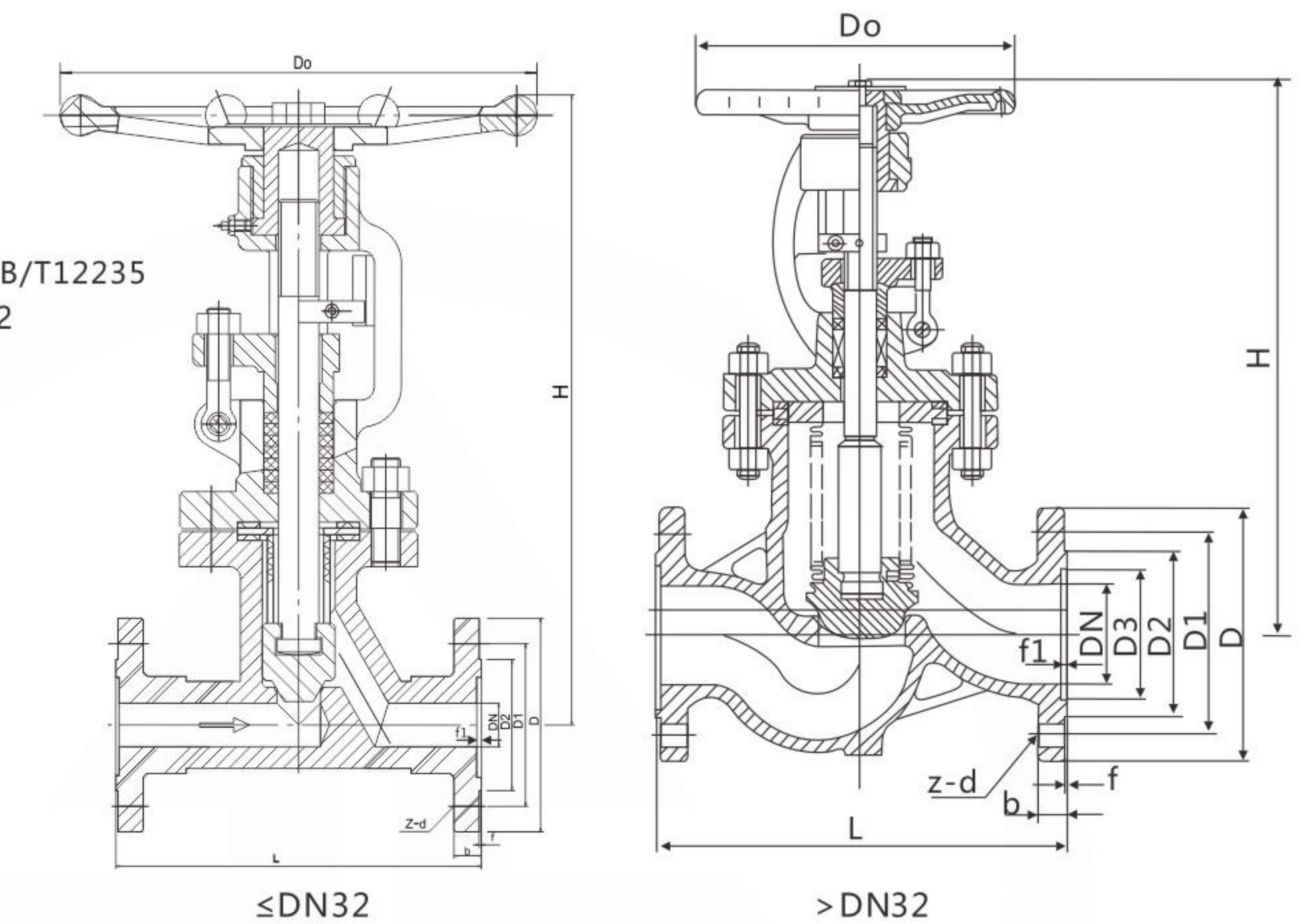

◆ 主要尺寸及重量

公称 通径 DN	尺寸(mm)										
	L	D	D1	D2	D3	f	f1	b	H	Do	Z-d
15	130	95	65	45	40	2	4	16	220	120	4-14
20	150	105	75	58	51	2	4	18	220	120	4-14
25	160	115	85	68	58	2	4	18	237	140	4-14
32	180	140	100	78	66	2	4	18	265	180	4-18
40	200	150	110	88	76	2	4	18	295	200	4-18
50	230	165	125	102	88	2	4	20	313	220	4-18
65	290	185	145	122	110	2	4	22	352	260	8-18
80	310	200	160	138	121	2	4	24	385	280	8-18
100	350	235	190	162	150	2	4.5	24	455	310	8-22
125	400	270	220	188	176	2	4.5	26	490	400	8-26
150	480	300	250	218	204	2	4.5	28	570	450	8-26
200	600	375	320	285	260	2	4.5	34	700	500	12-30
250	622	450	385	345	313	2	4.5	38	850	580	12-33
300	711	515	450	410	364	2	4.5	42	1020	580	16-33

WJ61H-25波纹管截止阀

Bellows Globe valve

设计制造标准： JB/T7746
 焊接端尺寸标准： JB/T7746
 结构长度按制造厂的标准
 波纹管标准： MSS SP-117
 检验与试验标准： GB/T26480
 Design and manufacturing standards: JB/T7746
 Welding terminal dimensions: JB/T7746
 The structure length is according to the manufacturer's standard
 Bellows standard: MSS sp-117
 Test and test standard: GB/T26480

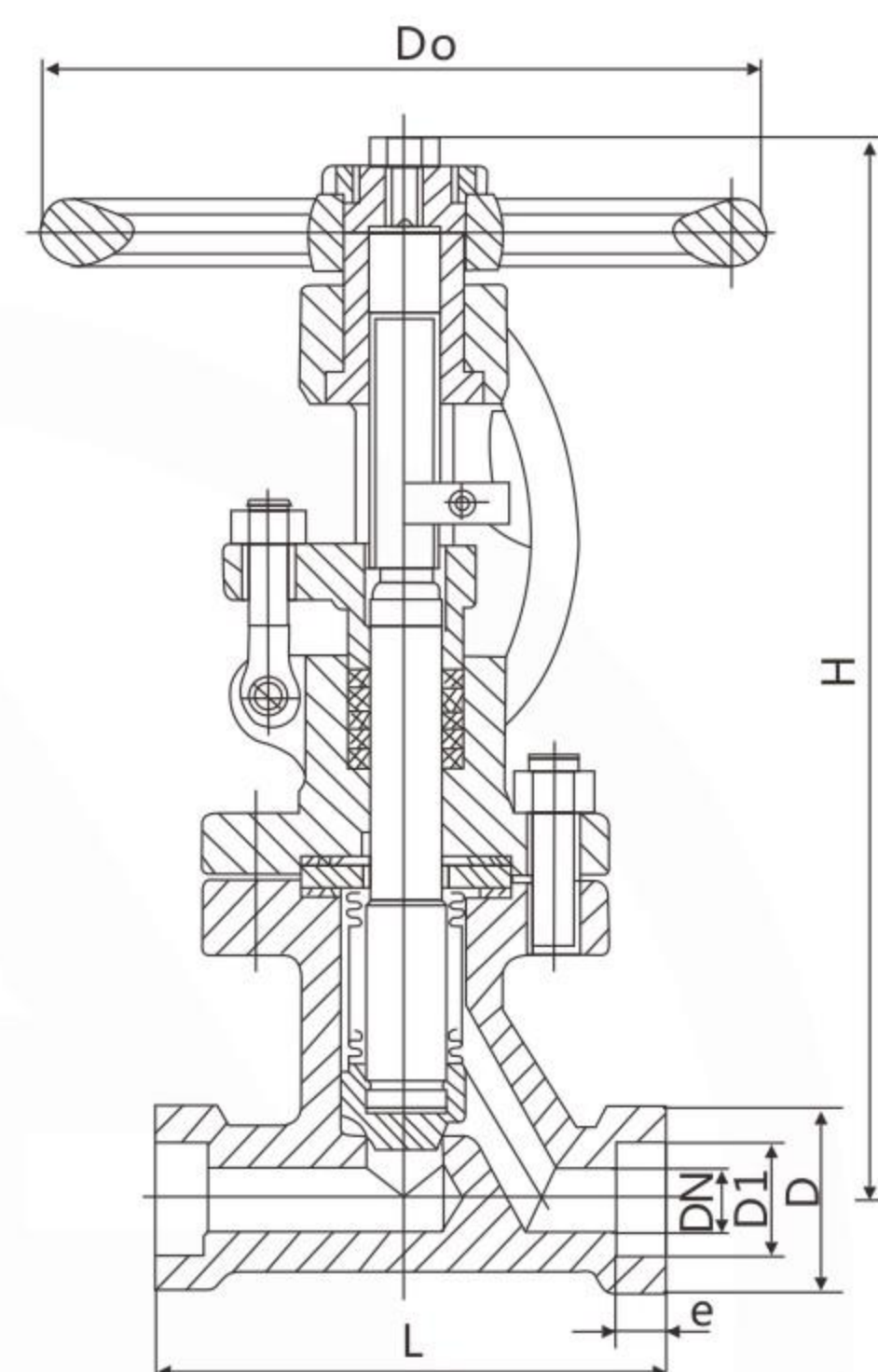

◆ 主要尺寸及重量

公称 口径 DN	尺寸(mm)					
	L	D	D1	e	H	Do
10	110	37	18.4	10	213	120
15	110	37	22.5	10	213	120
20	130	42	28.5	11	220	120
25	140	50	34.5	12	235	140
32	160	55	43	14	260	180
40	180	64	49	15	315	200
50	230	85	61	18	335	220

WJ61H-25波纹管截止阀

Bellows Globe valve

设计制造标准： GB/T12235
 焊接端尺寸标准： GB/T12224
 结构长度标准： GB/T12221
 波纹管标准： MSS SP-117
 检验与试验标准： GB/T26480
 Design and manufacturing standard: GB/T12235
 Welding terminal dimensions: GB/T12224
 Structure length standard: GB/T12221
 Bellows standard: MSS sp-117
 Test and test standard: GB/T26480

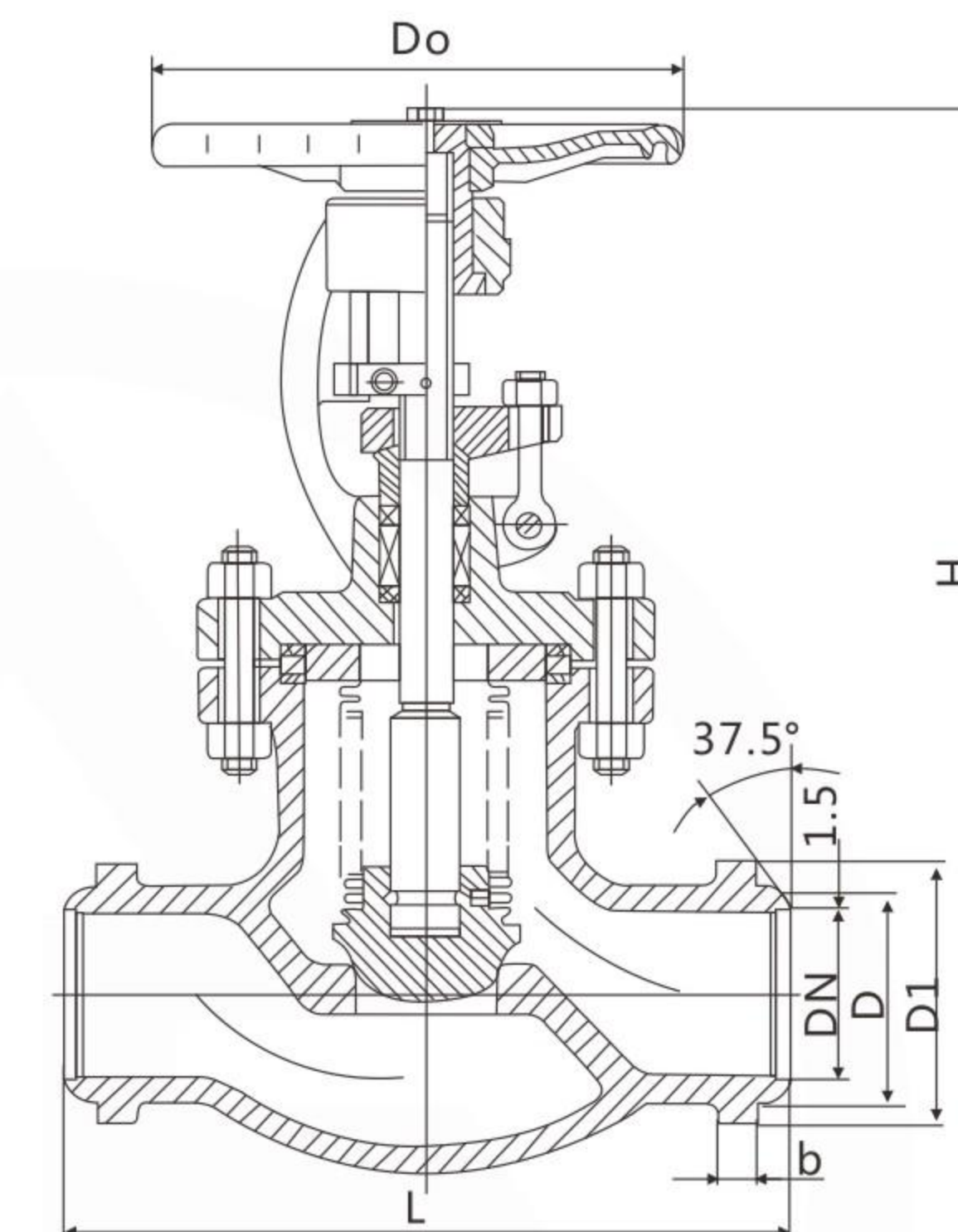

◆ 主要尺寸及重量

公称 口径 DN	尺寸(mm)					
	L	H	D	D1	b	Do
65	290	360	76.1	110	11	260
80	310	390	88.9	128	14	280
100	350	455	114.3	150	15	310
125	400	485	139	180	16	400
150	480	570	168.3	218	16	450
200	600	680	219.1	265	16	500
250	622	860	273	330	24	580
300	711	1020	323.9	395	27	580
350	850	1175	355.6	450	30	750
400	970	1290	406.4	520	30	810
450	978	1900	457	580	38	900
500	1016	2100	508	600	45	900
600	1295	2300	610	700	50	1000

WJ41H-150Lb波纹管截止阀

Bellows Globe valve

设计制造标准：ASME B16.34、BS1873
连接法兰尺寸标准：ASME B16.5
结构长度标准：ASME B16.10
波纹管标准：MSS SP-117
检验与试验标准：API598

Design and manufacturing standards: ASME B16.34、BS1873
Flange dimension standard: ASME B16.5
Structural length standard: ASME B16.10
Bellows standard: MSS sp-117
Inspection and testing standard: API598

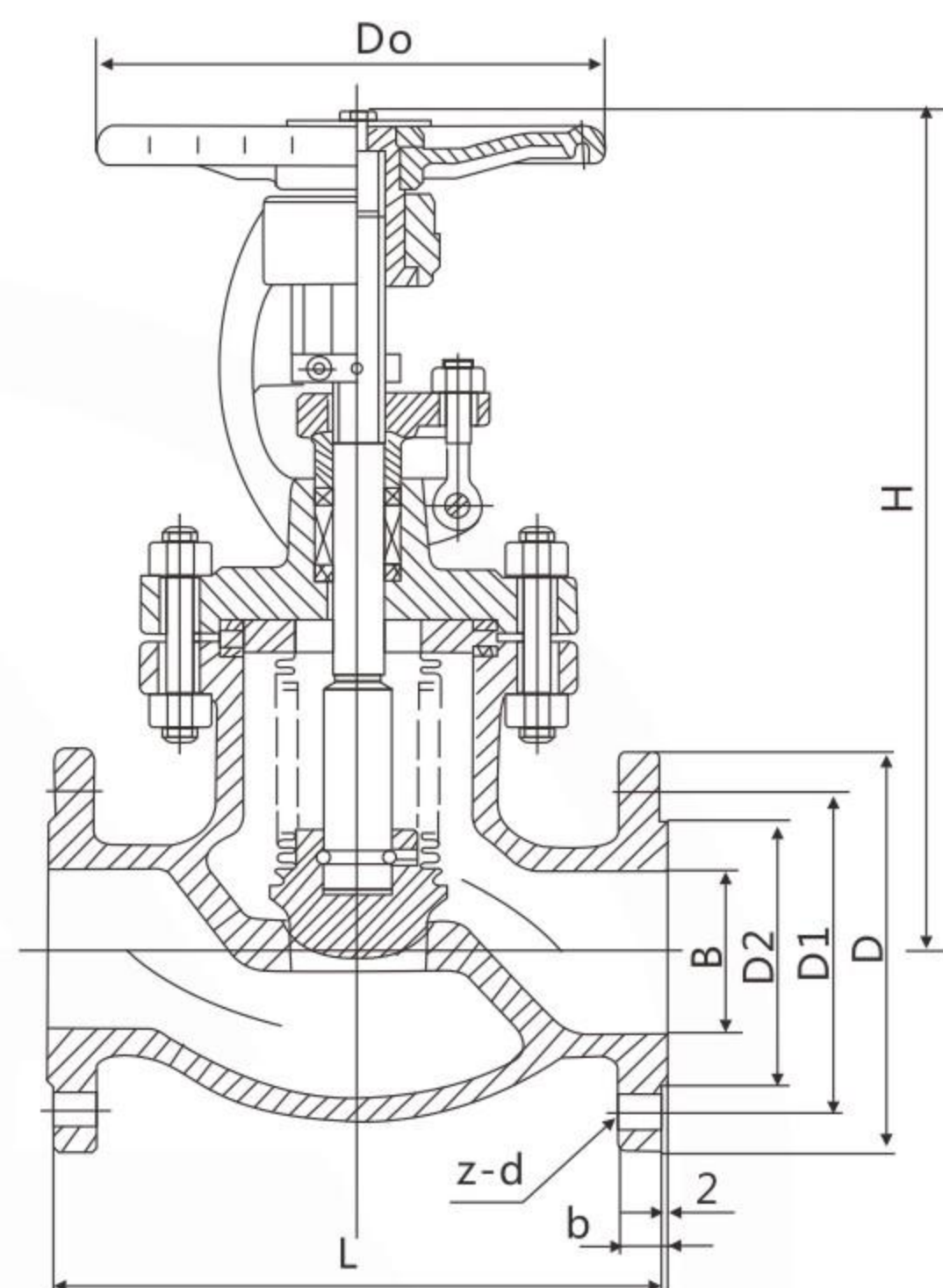

◆ 主要尺寸及重量

公称通径 NPS/DN		尺寸(mm)								
Inch	mm	L	D	D1	D2	B	b	H	Do	Z-d
1/2	15	108	90	60.3	34.9	15	9.6	205	120	4-16
3/4	20	117	100	69.9	42.9	20	11.2	205	120	4-16
1	25	127	110	79.4	50.8	25	12.7	216	140	4-16
1 1/2	40	165	125	98.4	73	38	15.9	290	180	4-16
2	50	203	150	120.7	92.1	51	17.5	328	200	4-19
2 1/2	65	216	180	139.7	104.8	63	20.7	348	220	4-19
3	80	241	190	152.4	127	77	22.3	395	280	4-19
4	100	292	230	190.5	157.2	101	22.3	435	310	8-19
5	125	356	255	215.9	185.7	126	22.3	472	350	8-22
6	150	406	280	241.3	215.9	152	23.9	555	450	8-22
8	200	495	345	298.5	269.9	203	27	640	450	8-22
10	250	622	405	362	323.8	254	28.6	750	580	12-26
12	300	698	485	431.8	381	305	30.2	1100	580	12-26
14	350	787	535	476.3	412.8	337	33.4	1200	750	12-29
16	400	914	595	539.8	469.9	387	35	1400	810	16-29

WJ41H-300Lb波纹管截止阀

Bellows Globe valve

设计制造标准：ASME B16.34、BS1873
连接法兰尺寸标准：ASME B16.5
结构长度标准：ASME B16.10
波纹管标准：MSS SP-117
检验与试验标准：API598

Design and manufacturing standards: ASME B16.34、BS1873
Flange dimension standard: ASME B16.5
Structural length standard: ASME B16.10
Bellows standard: MSS sp-117
Inspection and testing standard: API598

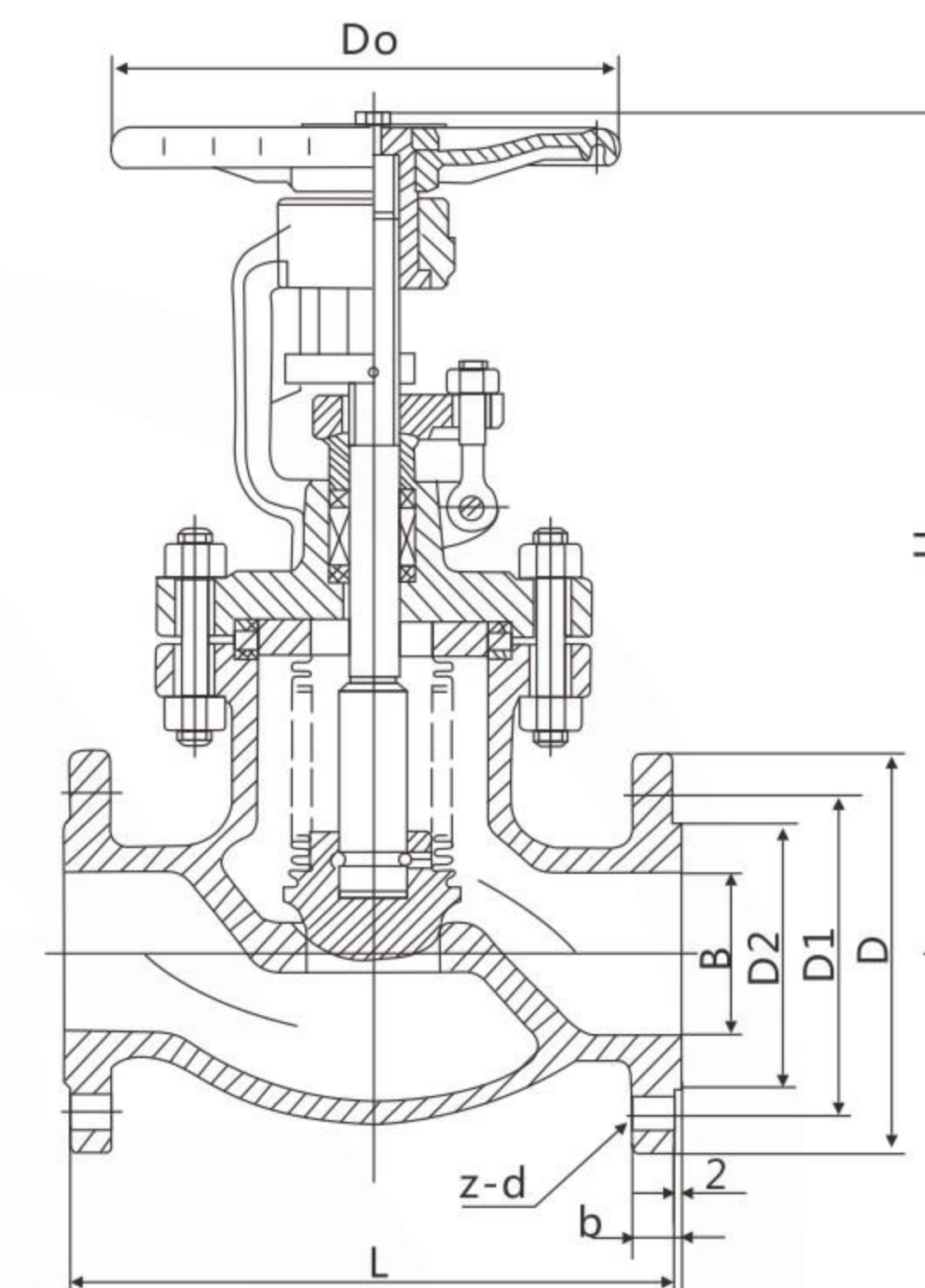

◆ 主要尺寸及重量

公称通径 NPS/DN		尺寸(mm)								
Inch	mm	L	D	D1	D2	B	b	H	Do	Z-d
1/2	15	152	95	66.7	34.9	15	12.7	210	120	4-16
3/4	20	178	115	82.6	42.9	20	14.3	210	120	4-19
1	25	203	125	88.9	50.8	25	15.9	225	140	4-19
1 1/2	40	229	155	114.3	73	38	19.1	292	180	4-22
2	50	267	165	127	92.1	51	20.7	333	200	8-19
2 1/2	65	292	190	149.2	104.8	63	23.9	385	220	8-22
3	80	318	210	168.3	127	77	27	430	280	8-22
4	100	356	255	200	157.2	101	30.2	480	310	8-22
5	125	400	280	235	185.7	127	33.4	585	350	8-22
6	150	444	320	269.9	215.9	151	35	570	460	12-22
8	200	559	380	330.2	269.9	201	39.7	740	550	12-26
10	250	622	445	387.4	323.8	251	46.1	1150	580	16-29
12	300	711	520	450.8	381	305	49.3	1350	580	16-32
14	350	838	585	514.4	412.8	337	52.4	1450	750	20-32
16	400	864	650	571.5	469.9	387	55.6	1550	810	20-35

WJ41H-600Lb波纹管截止阀

Bellows Globe valve

设计制造标准：ASME B16.34、BS1873
 连接法兰尺寸标准：ASME B16.5
 结构长度标准：ASME B16.10
 波纹管标准：MSS SP-117
 检验与试验标准：API598
 Design and manufacturing standards: ASME B16.34、BS1873
 Flange dimension standard: ASME B16.5
 Structural length standard: ASME B16.10
 Bellows standard: MSS sp-117
 Inspection and testing standard: API598

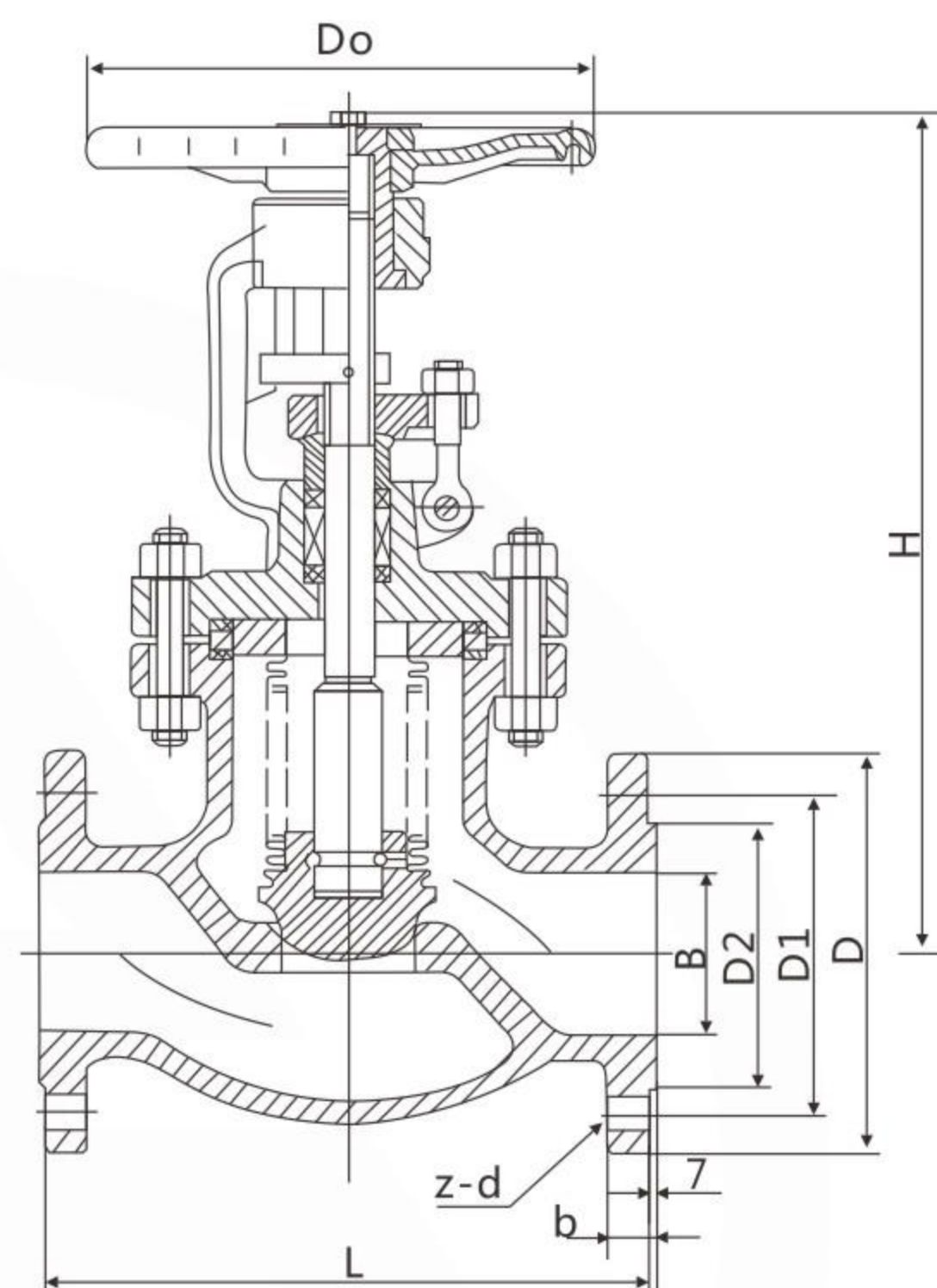

◆ 主要尺寸及重量

公称通径 NPS/DN		尺寸(mm)								
Inch	mm	L	D	D1	D2	B	b	H	Do	Z-d
1/2	15	165	95	66.7	34.9	15	14.3	248	120	4-16
3/4	20	190	115	82.6	42.9	20	15.9	252	120	4-19
1	25	216	125	88.9	50.8	25	17.5	272	140	4-19
1 1/2	40	241	155	114.3	73	38	22.3	340	180	4-22
2	50	292	165	127	92.1	51	25.4	350	200	8-19
2 1/2	65	330	190	149.2	104.8	63	28.6	410	220	8-22
3	80	356	210	168.3	127	77	31.8	430	280	8-22
4	100	432	275	215.9	157.2	101	38.1	520	360	8-26
5	125	508	330	266.7	185.7	125	44.5	590	360	8-29
6	150	559	355	292.1	215.9	149	47.7	600	460	12-29
8	200	660	420	349.2	269.9	200	55.6	760	550	12-32
10	250	787	510	431.8	323.8	251	63.5	1190	600	16-35
12	300	838	560	489	381	305	66.7	1390	650	20-35
14	350	889	605	527	412.8	337	69.9	1290	750	20-38
16	400	991	685	603.2	469.9	387	76.2	1590	810	20-41

WJ61H-150/300Lb波纹管截止阀

Bellows Globe valve

设计制造标准：ASME B16.34、BS1873
 焊接端尺寸标准：ASME B16.25/ASME B16.11
 结构长度标准：ASME B16.10
 波纹管标准：MSS SP-117
 检验与试验标准：API598
 Design and manufacturing standards: ASME B16.34、BS1873
 Welding terminal dimensions: ASME B16.25/ASME B16.11
 Structural length standard: ASME B16.10
 Bellows standard: MSS sp-117
 Inspection and testing standard: API598

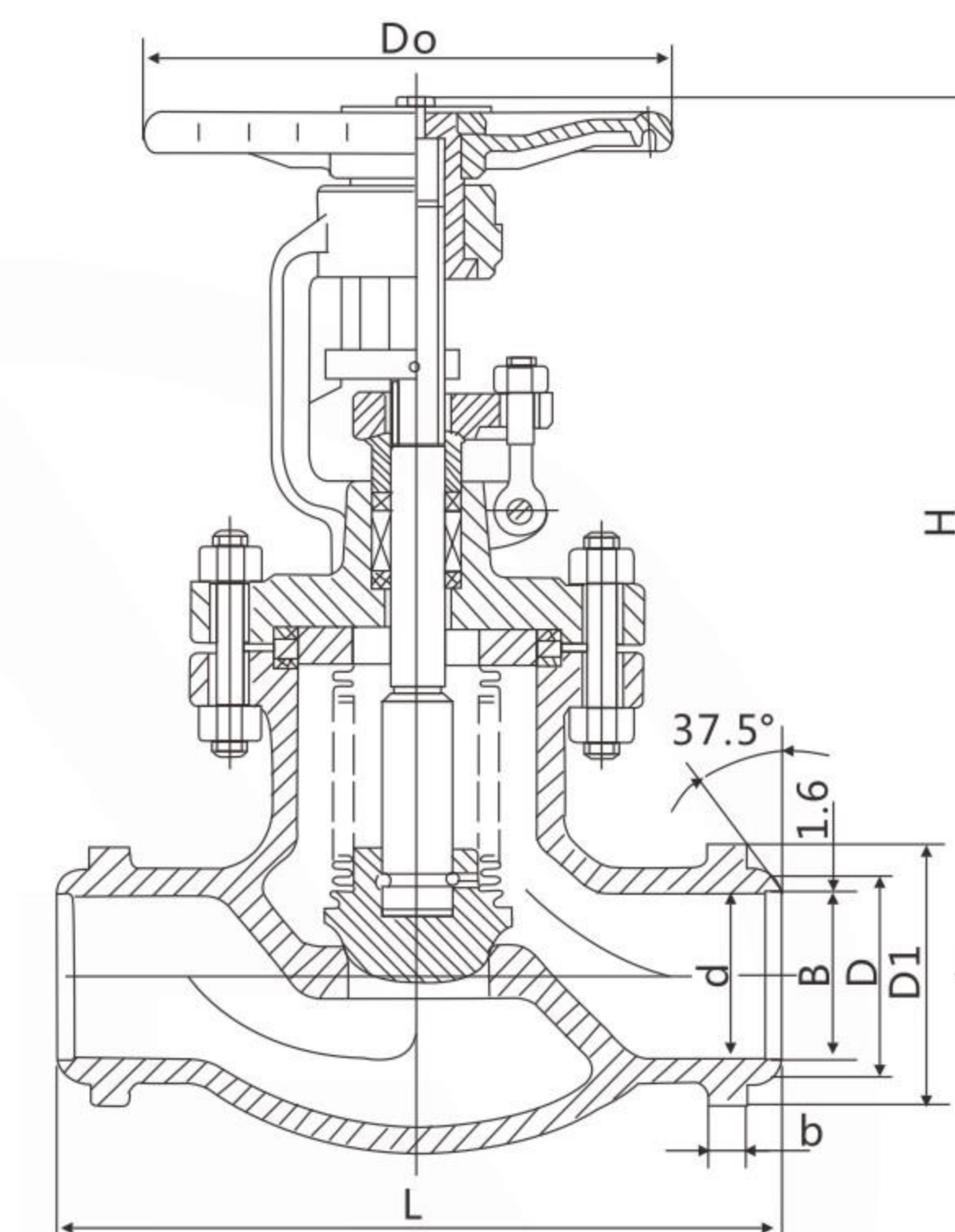

◆ 主要尺寸及重量

公称通径 NPS/DN		压力级磅级													
		150Lb							300Lb						
Inch	mm	L	d	D	D1	b	H	Do	L	d	D	D1	b	H	Do
2	50	203	50	60.3	100	11	328	200	267	50	60.3	100	11	360	250
3	80	241	78	88.9	128	14	395	220	318	78	88.9	128	14	430	280
4	100	292	101	114.3	150	15	435	310	356	101	114.3	150	15	470	310
5	125	356	125	139	180	16	472	350	400	125	139	180	16	580	350
6	150	406	149	168.3	218	16	555	450	444	149	168.3	218	16	585	460
8	200	495	200	219.1	265	16	640	450	559	200	219.1	265	16	730	530
10	250	622	248	273.1	330	24	685	580	622	248	273.1	330	24	1150	580
12	300	698	300	323.9	395	27	1100	580	711	300	323.9	395	27	1350	580
14	350	787	337	355.6	450	30	1200	750	838	337	355.6	450	30	1350	750
16	400	914	380	406.4	520	30	1400	810	864	380	406.4	520	30	1550	810

WZ41H-16/25波纹管闸阀

Bellows Gate valve

设计制造标准： JB/T7746、GB/T12234
连接法兰尺寸标准： HG/T20592
结构长度标准： GB/T12221
波纹管标准： MSS SP-117
检验与试验标准： GB/T26480

Design and manufacturing standards: JB/T7746、GB/T12234
Flange dimension standard: HG/T20592
Structure length standard: GB/T12221
Bellows standard: MSS sp-117
Test and test standard: GB/T26480

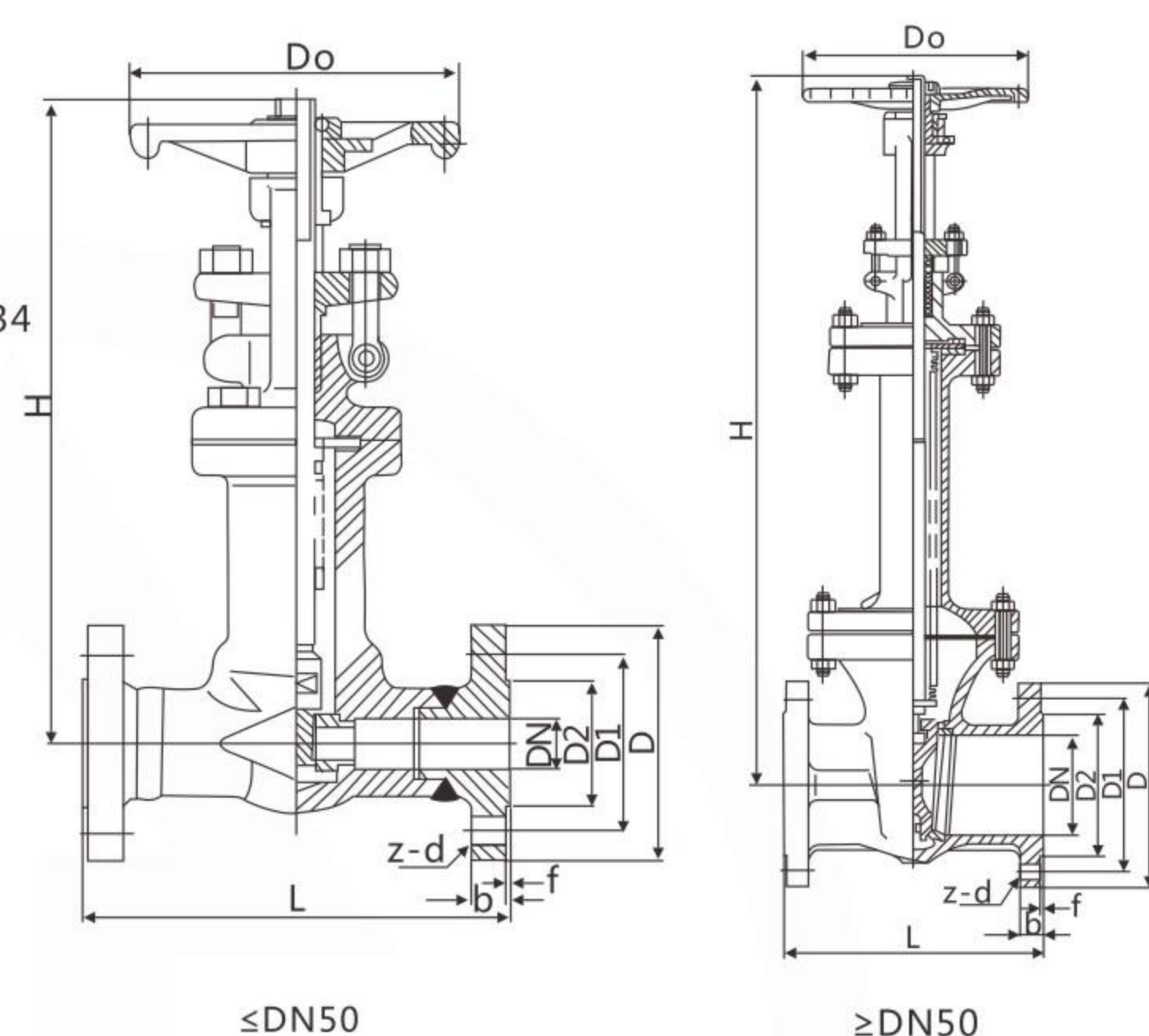

◆ 主要尺寸及重量

公称通径 DN	尺寸(mm)												
	L	D	D1	D2	b	H	Do	Z-d					
15	130	95	65	45	16	16	235	120	4-14				
20	150	105	75	58	18	18	235	120	4-14				
25	165	115	85	68	18	18	280	140	4-14				
32	180	140	100	78	18	18	380	180	4-18				
40	200	150	110	88	18	18	380	180	4-18				
50	250	165	125	102	18	20	630	220	4-18				
65	270	185	145	122	18	22	630	250	8-18				
80	280	200	160	138	20	24	655	280	8-18				
100	300	220	180	158	20	24	793	300	8-18	8-22			
125	325	250	210	188	22	26	1050	350	8-18	8-26			
150	350	285	240	212	22	28	1095	400	8-22	8-26			
200	400	340	295	268	24	30	1330	450	12-22	12-26			
250	450	405	355	320	26	32	1640	500	12-26	12-30			
300	500	460	410	378	28	34	1895	550	12-26	16-30			
350	550	520	470	428	30	38	2125	600	16-26	16-33			
400	600	580	525	490	32	40	2380	700	16-30	16-36			

注：说明表格每栏由供一组数据均为1.6MPa、2.5MPa均相同数据。前者为1.6MPa，后者为2.5MPa的。

WZ41H-40波纹管闸阀

Bellows Gate valve

设计制造标准： GB/T12234
连接法兰标准： HG/T20592
结构长度标准： GB/T12221
波纹管标准： MSS SP-117
检验与试验标准： GB/T26480

Design and manufacturing standard: GB/T12234
Flange dimension standard: HG/T20592
Structure length standard: GB/T12221
Bellows standard: MSS sp-117
Test and test standard: GB/T26480

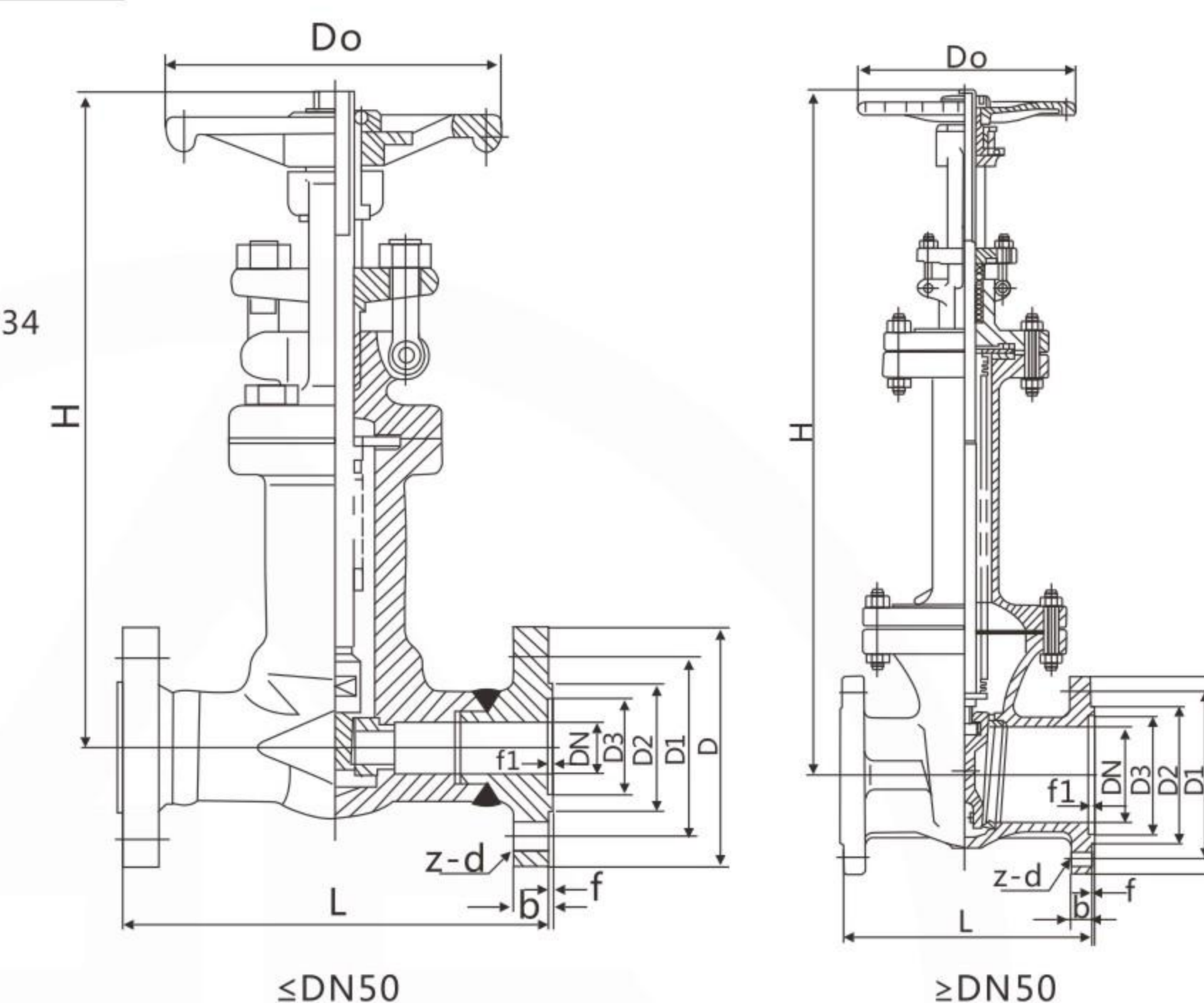

◆ 主要尺寸及重量

公称通径 DN	尺寸(mm)											
	L	D	D1	D2	D3	f	f1	b	H	Do	Z-d	
15	130	95	65	45	40	2	4	16	235	120	4-14	
20	150	105	75	58	51	2	4	18	235	120	4-14	
25	165	115	85	68	58	2	4	18	280	140	4-14	
32	180	140	100	78	66	2	4	18	380	180	4-18	
40	200	150	110	88	76	2	4	18	380	180	4-18	
50	250	165	125	102	88	2	4	20	630	220	4-18	
65	280	185	145	122	110	2	4	22	558	250	8-18	
80	310	200	160	138	121	2	4	24	655	280	8-18	
100	350	235	190	162	150	2	4.5	24	793	300	8-22	
125	400	270	220	188	176	2	4.5	26	1050	350	8-26	
150	450	300	250	218	204	2	4.5	28	1095	400	8-26	
200	550	375	320	285	260	2	4.5	34	1330	450	12-30	
250	650	450	385	345	313	2	4.5	38	1640	500	12-33	
300	750	515	450	410	364	2	4.5	42	1895	550	16-33	

WZ61H-25波纹管闸阀

Bellows Gate valve

设计制造标准： JB/T7746、GB/T12234
 焊接尺寸标准： GB/T12224/JB/T7746
 结构长度标准： GB/T12221/JB/T7746
 波纹管标准： MSS SP-117
 检验与试验标准： GB/T26480
 Design and manufacturing standards: JB/T7746、GB/T12234
 Welding terminal dimensions: GB/T12224/JB/T7746
 Structural length standard: GB/T12221/JB/T7746
 Bellows standard: MSS sp-117
 Inspection and testing standard: GB/T26480

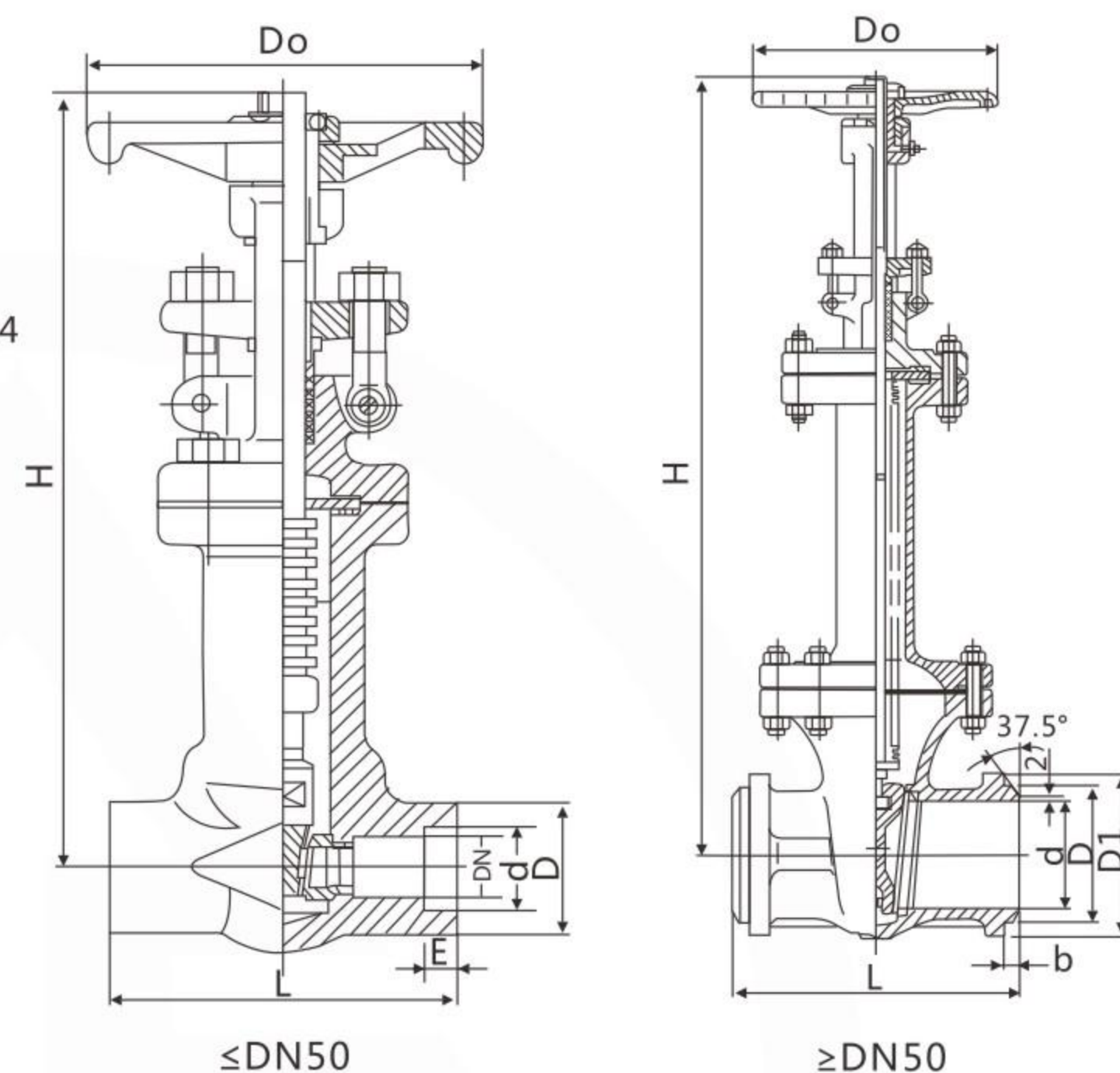

◆ 主要尺寸及重量

公称通径 DN	压力级磅级：25							
mm	L	H	Do	D	d	E	D1	b
15	79	235	120		22.5	10		
20	92	235	120		28.5	11		
25	111	280	140		34.5	12		
32	120	380	160		43	14		
40	140	380	180		49	15		
50	178	630	200		61	18		
65	270	585	250	76.1			110	11
80	280	655	280	88.9			128	14
100	300	793	310	114.3			150	15
150	350	1095	400	168.3			218	16
200	400	1330	450	219.1			265	16
250	450	1640	500	273			330	24
300	500	1895	550	323.9			395	27
350	550	2125	600	355.6			450	30
400	600	2380	700	406.4			520	30
450	660	3200	700	457			580	38
500	700	3650	750	508			630	45
600	800	4190	850	610			740	50

WZ41H-150Lb 波纹管闸阀

Bellows Gate valve

设计制造标准： API 602、API 600
 连接法兰尺寸标准： ASME B16.5
 结构长度标准： ASME B16.10
 波纹管标准： MSS SP-117
 检验与试验标准： API598
 Design and manufacturing standard: API 602、API 600
 Flange dimension standard: ASME B16.5
 Structural length standard: ASME B16.10
 Bellows standard: MSS sp-117
 Inspection and testing standard: API598

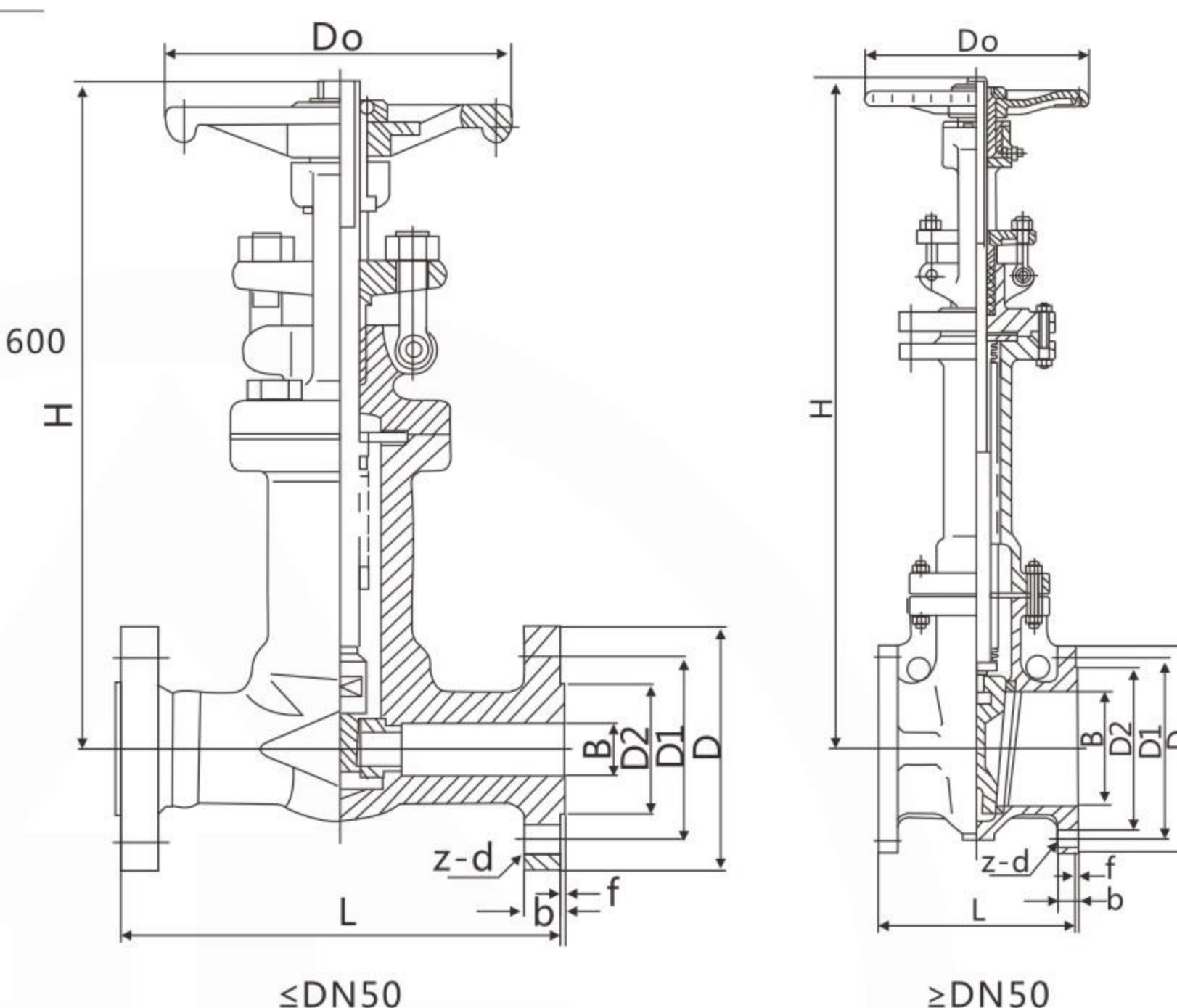

◆ 主要尺寸及重量

公称通径		尺寸(mm)								
Inch	DN(mm)	L	D	D1	D2	B	b	H	Do	Z-d
1/2	15	108	90	60.3	34.9	15	9.6	255	120	4-16
3/4	20	117	100	69.9	42.9	20	11.2	255	120	4-16
1	25	127	110	79.4	50.8	25	12.7	280	140	4-16
1 1/4	32	140	115	88.9	63.5	32	14.3	360	100	4-16
1 1/2	40	165	125	98.4	73	38	15.9	380	140	4-16
2	50	178	150	120.7	92.1	51	17.5	530	160	4-19
2 1/2	65	190	180	139.7	104.8	63	20.7	558	180	4-19
3	80	203	190	152.4	127	77	22.3	650	260	4-19
4	100	229	230	190.5	157.2	101	22.3	795	300	8-19
5	125	254	255	215.9	185.7	127	22.3	850	300	8-22
6	150	267	280	241.3	215.9	152	23.9	970	400	8-22
8	200	292	345	298.5	269.9	203	27	1290	450	8-22
10	250	330	405	362	323.8	254	28.6	1500	500	12-26
12	300	356	485	421.8	381	305	30.2	1895	500	12-26
14	350	381	535	476.3	412.8	355	33.4	2125	600	12-29
16	400	406	595	539.8	469.9	387	35	2380	700	16-29
18	450	432	635	577.9	533.4	438	38.1	3000	700	16-32
20	500	457	700	635	584.2	489	41.3	3650	750	20-32
24	600	508	815	749.3	692.2	591	46.1	4190	850	20-35

WZ41H-300Lb 波纹管闸阀

Bellows Gate valve

设计制造标准： API 602、API 600
连接法兰标准： ASME B16.5
结构长度标准： ASME B16.10
波纹管标准： MSS SP-117
检验与试验标准： API598

Design and manufacturing standard: API 602、API 600
Flange dimension standard: ASME B16.5
Structural length standard: ASME B16.10
Bellows standard: MSS sp-117
Inspection and testing standard: API598

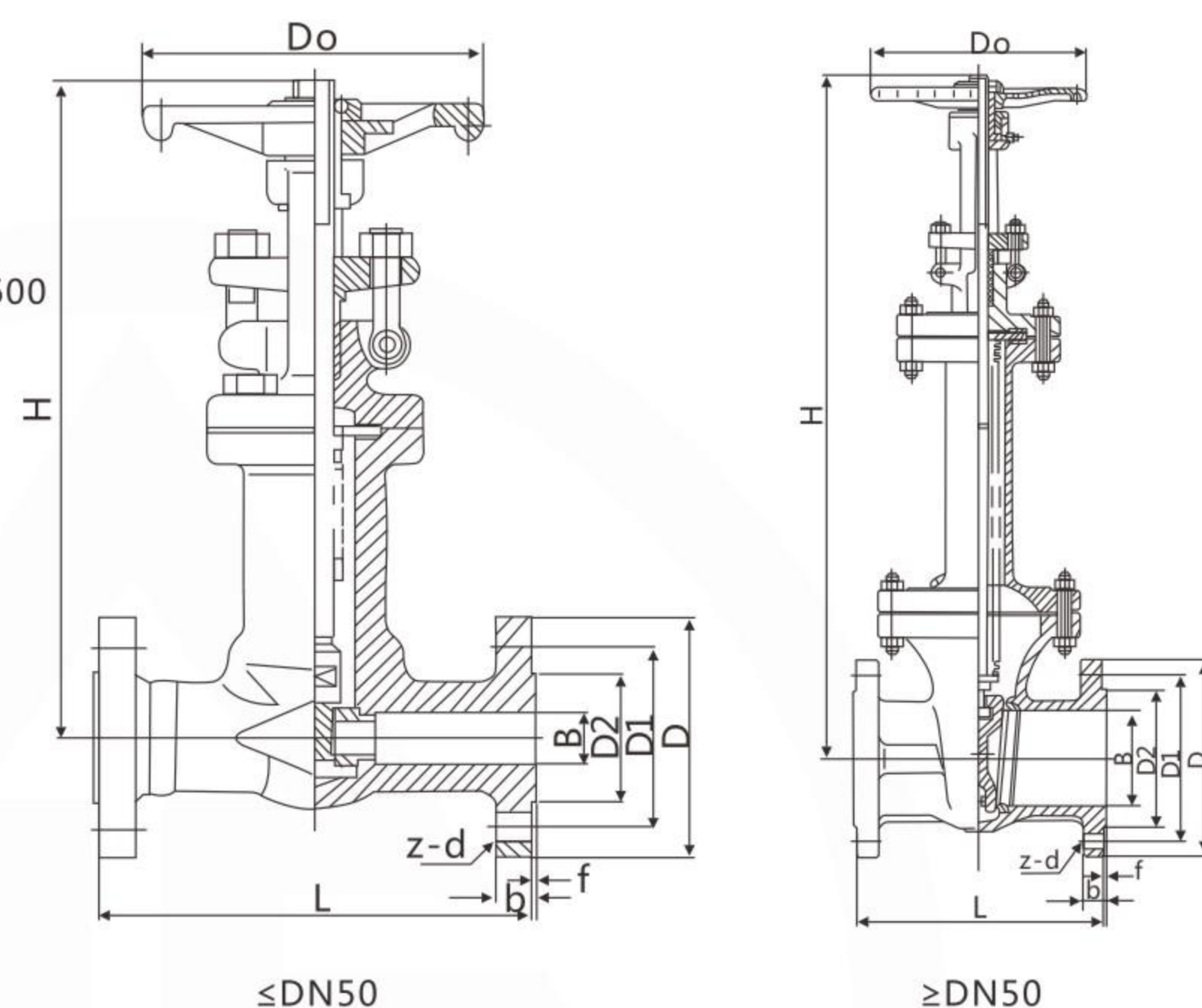

◆ 主要尺寸及重量

公称通径 DN		尺寸(mm)									
Inch	mm	L	D	D1	D2	B	b	f	H	Do	Z-d
1/2	15	140	95	66.7	34.9	15	12.7	2	255	120	4-16
3/4	20	152	115	82.6	42.9	20	14.3	2	255	120	4-19
1	25	165	125	88.9	50.8	25	15.9	2	280	140	4-19
1 1/4	32	178	135	98.4	63.5	32	17.5	2	360	160	4-19
1 1/2	40	190	155	114.3	73	38	19.1	2	380	180	4-22
2	50	216	165	127	92.1	51	20.7	2	530	220	8-19
2 1/2	65	241	190	149.2	104.8	64	23.9	2	558	250	8-22
3	80	282	210	168.3	127	78	27	2	665	280	8-22
4	100	305	255	200	157.2	101	30.2	2	795	310	8-22
5	125	381	280	235	185.7	127	33.4	2	850	350	8-22
6	150	403	320	269.9	215.9	150.5	35	2	970	400	12-22
8	200	419	380	330.2	269.9	201	39.7	2	1290	450	12-26
10	250	457	445	387.4	323.8	252	46.1	2	1500	500	16-29
12	300	502	520	450.8	381	305	49.3	2	1895	550	16-32

WZ41H-600Lb 波纹管闸阀

Bellows Gate valve

设计制造标准： API 602、API 600
连接法兰标准： ASME B16.5
结构长度标准： ASME B16.10
波纹管标准： MSS SP-117
检验与试验标准： API598

Design and manufacturing standard: API 602、API 600
Flange dimension standard: ASME B16.5
Structural length standard: ASME B16.10
Bellows standard: MSS sp-117
Inspection and testing standard: API598

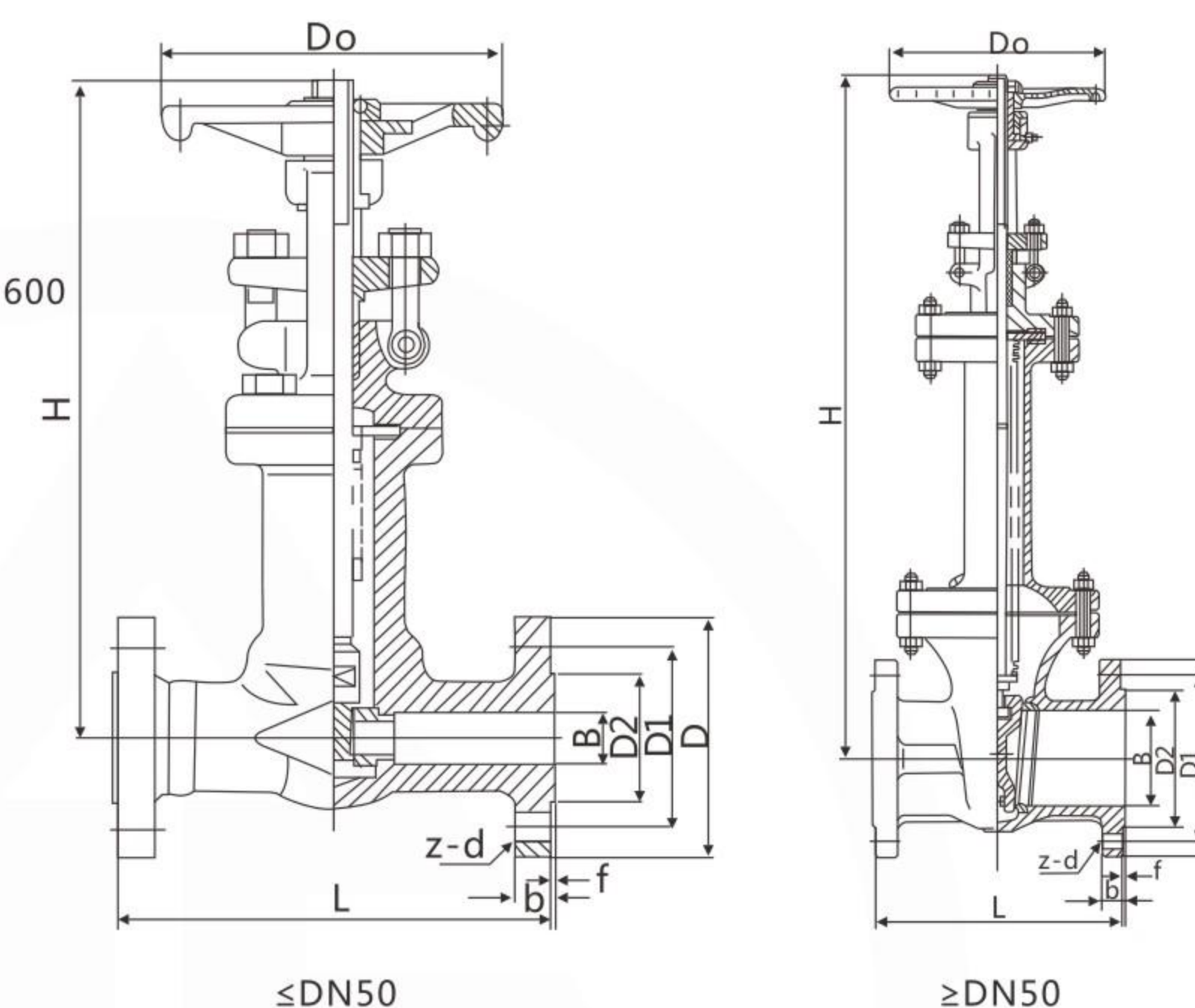

◆ 主要尺寸及重量

公称通径 DN		尺寸(mm)									
Inch	mm	L	D	D1	D2	B	b	f	H	Do	Z-d
1/2	15	165	95	66.7	34.9	15	14.3	2	265	120	4-16
3/4	20	190	115	82.6	42.9	20	15.9	2	265	120	4-19
1	25	216	125	88.9	50.8	25	17.5	2	300	140	4-19
1 1/4	32	229	135	98.4	63.5	32	20.7	2	380	160	4-19
1 1/2	40	241	155	114.3	73	38	22.3	2	410	180	4-22
2	50	292	165	127	92.1	51	25.4	2	570	260	8-19
2 1/2	65	330	190	149.2	104.8	64	28.6	2	580	250	8-22
3	80	356	210	168.3	127	76	31.8	2	720	300	8-22
4	100	432	275	215.9	157.2	100	38.1	2	810	310	8-26
5	125	508	330	266.7	185.7	127	44.5	2	890	350	8-29
6	150	559	355	292.1	215.9	152	47.7	2	1000	400	12-29
8	200	660	420	349.2	269.9	203	55.6	2	1320	450	12-32
10	250	787	510	431.8	323.8	254	63.5	2	1550	500	16-35
12	300	838	560	489	381	305	66.7	2	2150	550	20-35

WZ61H-150/300Lb波纹管闸阀

Bellows Gate valve

设计制造标准： API 602、API 600
焊接尺寸标准： ASME B16.25/ASME B16.11
结构长度标准： ASME B16.10
波纹管标准： MSS SP-117
检验与试验标准： API598

Design and manufacturing standard: API 602、API 600
Welding dimension standard: ASME B16.25/ASME B16.11
Structural length standard: ASME B16.10
Bellows standard: MSS sp-117
Inspection and testing standard: API598

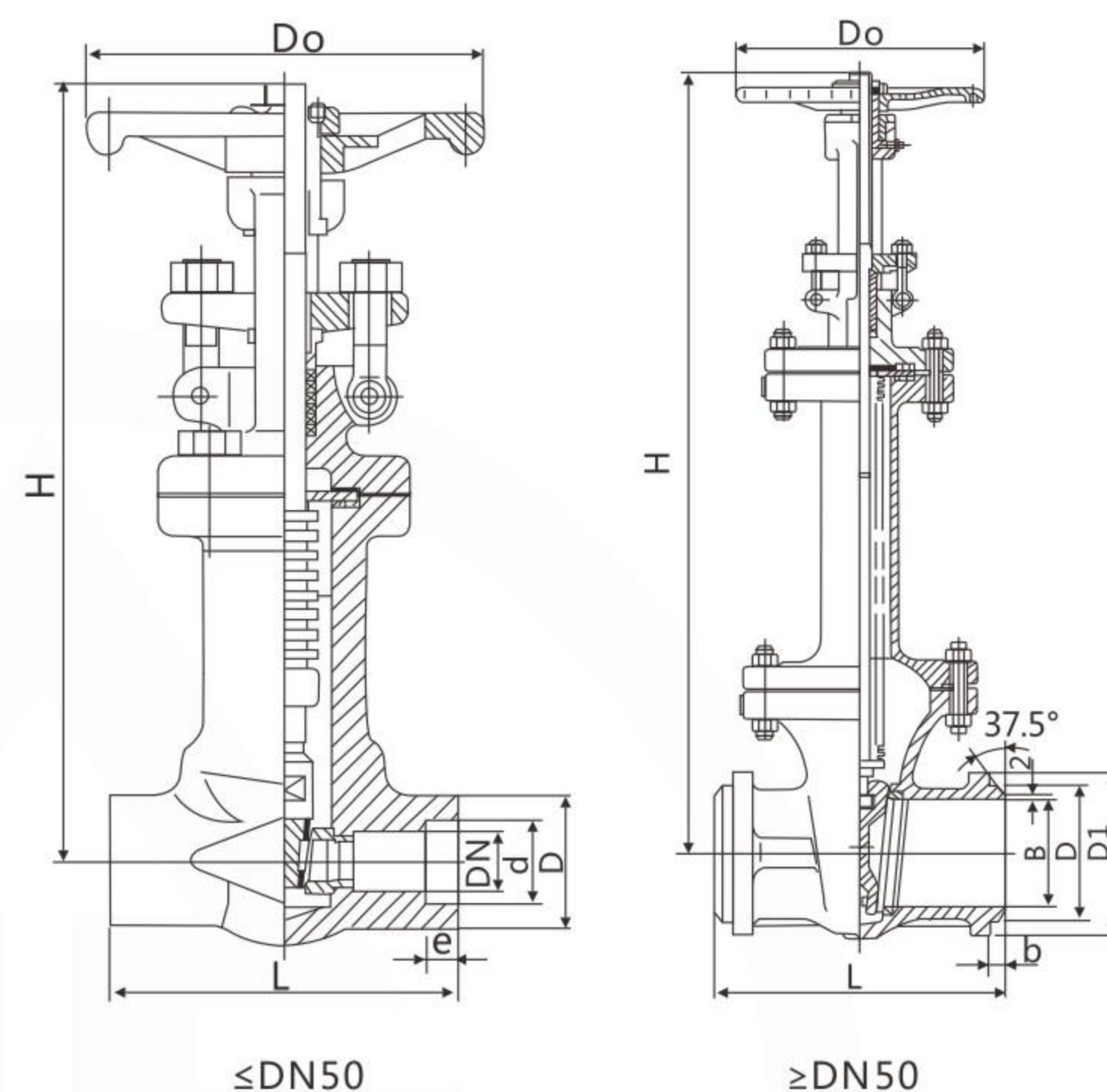

◆ 主要尺寸及重量

公称通径 DN		压力级磅级											
		150Lb						300Lb					
mm	Inch	L	H	Do	D	d	e	L	H	Do	D	d	e
1/2	15	79	255	120	33	22.5	10	79	255	120	33	22.5	10
3/4	20	92	255	120	38	28.5	12.5	92	255	120	38	28.5	12.5
1	25	111	280	140	48	34.5	12.5	111	280	140	48	34.5	12.5
1 1/4	32	120	360	140	56	43	12.5	120	360	140	55	43	12.5
1 1/2	40	140	360	140	64	49	12.5	140	360	140	64	49	12.5
2	50	178	380	160	73	61	12.5	178	380	160	73	61	12.5
2 1/2	65	190	630	180				241	630	180			
3	80	203	650	260				282	650	260			
4	100	229	795	300				305	795	300			
5	125	254	850	300				381	850	300			
6	150	267	970	400				403	970	400			
8	200	292	1290	450				419	1290	450			
10	250	330	1500	500				457	1500	500			
12	300	356	1895	500				502	1895	500			

Quality assurance and after-sales service commitment

质量保证和售后服务承诺

我公司对质量保证和售后服务做如下承诺：

- 一、严格按照ISO9001质量保证体系执行生产。
- 二、保证出厂产品按照相关国家标准制造和检验，不合格产品决不出厂。认真履行国家工业产品售后服务有关规定，兑现产品三包。对出厂产品自发货日起十八个月内，在产品规定的正常操作条件下我公司将负责质保期内质量完好。
- 三、如用户对我公司产品提出质量异议，公司保证在接到用户提出异议后2小时内作出响应。若需要现场解决，保证迅速及时派出专业技术服务人员，就相关问题给出合理解决方案。对每位用户反馈产品质量问题及处理结果我公司将存档改进不断创新。

The company does three things about quality assurance and after-sales service:

1. Strictly follow the ISO9001 quality system to carry out production.
2. Ensure that all outgoing products are produced and inspected according to relevant international standards. Ensure strict implementation of the three packages of products, strictly implement the national industrial products after-sales service regulations, and to the factory products within 18 months from the date of spontaneous delivery, our company will be responsible for the quality of the warranty period under normal operating conditions.
3. If the customer disputes the quality of our products, the company guarantees that within 2 hours after receiving the objection from the user to deal with. If it is necessary to solve the problem on site, make sure to send professional technical service personnel, and ask questions and give them the first time a solution. Our company will keep an archive of the quality problems and the results of each user's feedback.

The above three points are my company's commitment to after-sales service and quality assurance. We sincerely welcome the users to criticize and correct, please give valuable advice and refer to improvement. I sincerely hope that we can have a pleasant cooperation.



感谢阅读 good luck!