

2 Port Solenoid Valve with Built-in Y-strainer

VXK Series

For Air, Water, Oil, Steam



RoHS

IP65

Space saving
and reduced
piping labor

60 mm (VXK21)
63.5 mm (VXK22/23)

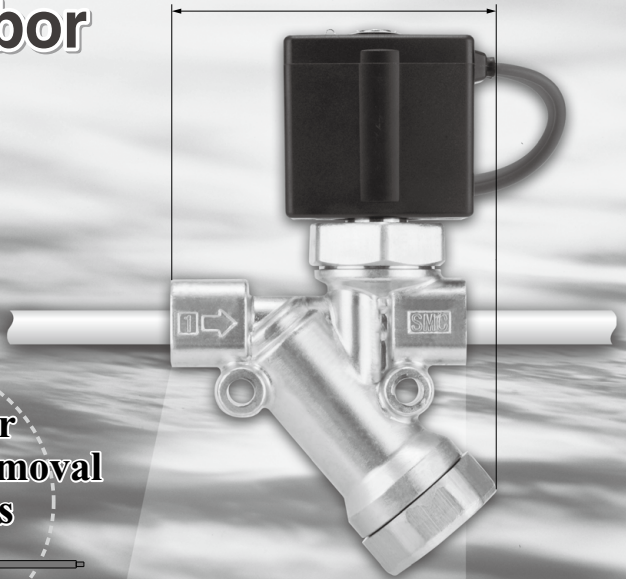

Built-in strainer
enabling the removal
of contaminants

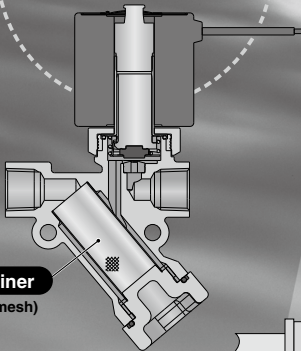

Strainer
(100 mesh)

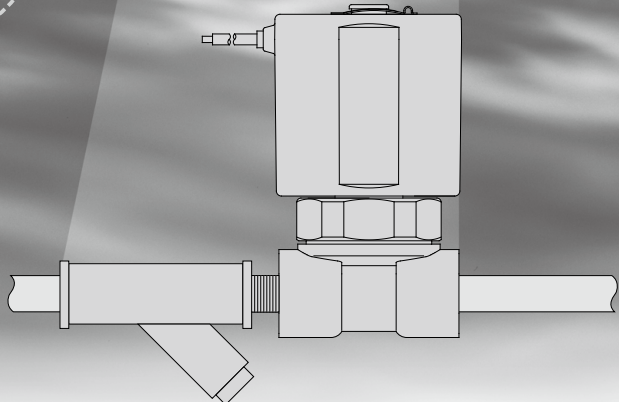

- VX2
- VXK**
- VXD
- VXZ
- VXS
- VXB
- VXE
- VXP
- VXR
- VXH
- VXF
- VX3
- VXA



Element can be replaced without removing piping.

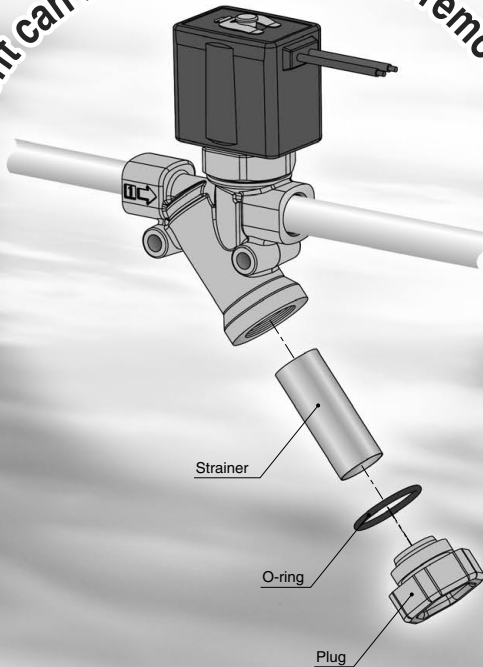

■ Variations

Direct Operated: VXK21/22/23 Series

● Valve

Normally closed (N.C.)

Normally open (N.O.)

● Solenoid Coil

Coil: Class B, Class H

● Rated Voltage

AC: 100 V, 200 V, 110 V, 220 V, 240 V
230 V, 48 V

DC: 24 V, 12 V

● Material

Body: C37

Seal: NBR, FKM, EPDM, PTFE

● Electrical Entry

Grommet

Conduit

DIN terminal

Conduit terminal



Normally Closed (N.C.)

	Model	VXK21	VXK22	VXK23
Office size	2 mmø	●	—	—
	3 mmø	●	●	●
	4.5 mmø	●	●	●
	6 mmø	—	●	●
	8 mmø	—	●	●
Port size		1/8, 1/4	1/4, 3/8	1/4, 3/8

Normally Open (N.O.)

	Model	VXK21	VXK22	VXK23
Office size	2 mmø	●	—	—
	3 mmø	●	●	●
	4.5 mmø	●	●	●
	6 mmø	—	●	●
Port size		1/8, 1/4	1/4, 3/8	1/4, 3/8

* Basic specifications are the same as those of the VX21/22/23 series.

Direct Operated 2 Port Solenoid Valve with Built-in Y-strainer



VXK21/22/23 Series

For Air, Water, Oil, Steam



Single Unit

Valve

Normally closed (N.C.)
Normally open (N.O.)

Solenoid Coil

Coil: Class B, Class H

Rated Voltage

100 VAC, 200 VAC, 110 VAC,
220 VAC, 240 VAC, 230 VAC,
48 VAC, 24 VDC, 12 VDC

Material

Body — C37
Seal — NBR, FKM, EPDM, PTFE

Electrical Entry

- Grommet
- Conduit
- DIN terminal
- Conduit terminal



Normally Closed (N.C.)

Model	VXK21	VXK22	VXK23
Orifice size			
2 mmø	●	—	—
3 mmø	●	●	●
4.5 mmø	●	●	●
6 mmø	—	●	●
8 mmø	—	●	●
Port size	1/8 1/4	1/4 3/8	1/4 3/8

Normally Open (N.O.)

Model	VXK21	VXK22	VXK23
Orifice size			
2 mmø	●	—	—
3 mmø	●	●	●
4.5 mmø	●	●	●
6 mmø	—	●	●
Port size	1/8 1/4	1/4 3/8	1/4 3/8

VX2

VXK

VXD

VXZ

VXS

VXB

VXE

VXP

VXR

VXH

VXF

VX3

VXA

VXK21/22/23 Series

Common Specifications

Standard Specifications

Valve specifications	Valve construction		Direct operated poppet	
	Withstand pressure	MPa	5.0	
	Body material		C37	
	Seal material		NBR, FKM, EPDM, PTFE	
	Enclosure		Dust-tight, Water-jet-proof type (IP65) ^{Note}	
	Environment		Location without corrosive or explosive gases	
Strainer specifications	Mesh		100	
	Material		Stainless steel	
Coil specifications	Rated voltage	AC	100 VAC, 200 VAC, 110 VAC, 220 VAC, 230 VAC, 240 VAC, 48 VAC	
		DC	24 VDC, 12 VDC	
	Allowable voltage fluctuation		±10% of rated voltage	
	Allowable leakage voltage	AC (Class B, Built-in full-wave rectifier type)		10% or less of rated voltage
		AC (Class B/H)		20% or less of rated voltage
		DC (Class B only)		2% or less of rated voltage
Coil insulation type		Class B, Class H		

Note) Electrical entry: Grommet with surge voltage suppressor (GS) has a rating of IP40.

Solenoid Coil Specifications

Normally Closed (N.C.)

DC Specification

Model	Power consumption (W)	Temperature rise (C°) ^{Note}
VXK21	4.5	45
VXK22	7	45
VXK23	10.5	60

AC Specification (Class B, Built-in full-wave rectifier type)

Model	Apparent power (VA) [*]	Temperature rise (C°) ^{Note}
VXK21	7	55
VXK22	9.5	60
VXK23	12	65

* There is no difference in the frequency and the inrush and energized apparent power because a rectifying circuit is used in the AC (Class B, Built-in full-wave rectifier type).

Note) Value at ambient temperature of 20°C and when the rated voltage is applied.

AC Specification

Model	Frequency (Hz)	Apparent power (VA)		Temperature rise (C°) ^{Note}
		Inrush	Energized	
VXK21	50	19	10	50
	60	16	8	45
VXK22	50	43	20	65
	60	35	17	60
VXK23	50	62	32	65
	60	52	27	60

Note) Value at ambient temperature of 20°C and when the rated voltage is applied.

Normally Open (N.O.)

DC Specification

Model	Power consumption (W)	Temperature rise (C°) ^{Note}
VXK21	4.5	45
VXK22	7	45
VXK23	10.5	60

AC Specification (Class B, Built-in full-wave rectifier type)

Model	Apparent power (VA) [*]	Temperature rise (C°) ^{Note}
VXK21	7	55
VXK22	9.5	60
VXK23	12	65

* There is no difference in the frequency and the inrush and energized apparent power because a rectifying circuit is used in the AC (Class B, Built-in full-wave rectifier type).

Note) Value at ambient temperature of 20°C and when the rated voltage is applied.

AC Specification

Model	Frequency (Hz)	Apparent power (VA)		Temperature rise (C°) ^{Note}
		Inrush	Energized	
VXK21	50	22	11	55
	60	18	8	50
VXK22	50	46	20	65
	60	38	18	60
VXK23	50	64	32	65
	60	54	27	60

Note) Value at ambient temperature of 20°C and when the rated voltage is applied.

VXK21/22/23 Series

Applicable Fluid Check List

All Options (Single Unit)

VXK2 0 - - 1

● Option symbol

Fluid and application	Option symbol	Seal material	Body/Shading coil material <small>Note 5)</small>	Coil insulation type <small>Note 4)</small>	Remarks
Air	Nil	NBR	C37/-	B	Select the built-in full-wave rectifier type for AC spec.
Medium vacuum, Non-leak, Oil-free <small>Note 1)</small>	V <small>Note 2)</small>	FKM	C37/-	B	Select the built-in full-wave rectifier type for AC spec.
Water	Nil	NBR	C37/Cu	B	
Heated water	E	EPDM	C37/Cu	H	
Oil <small>Note 3)</small>	A	FKM	C37/Cu	B	
	D			H	
Steam	S	PTFE	C37/Cu	H	
Other combinations	B	EPDM	C37/Cu	B	
	C	PTFE			

Note 1) The leakage amount (10^{-3} Pa·m³/s) of the option "V" is a value when the differential pressure is 0.1 MPa.

Note 2) Option "V" is the oil-free treatment.

Note 3) The dynamic viscosity of the fluid must not exceed 50 mm²/s.

The special construction of the armature adopted in the built-in full-wave rectifier type gives an improvement in OFF response by providing clearance on the absorbed surface when it is switched ON.

Select the DC spec. or AC spec. built-in full-wave rectifier type when the dynamic viscosity is higher than water or when the OFF response is prioritized.

Note 4) Coil insulation type Class H: AC spec. only

Note 5) There is no shading coil attached to the DC spec. or AC spec. built-in full-wave rectifier type.

* Please contact SMC when fluids other than above are used.

VX2

VXK

VXD

VXZ

VXS

VXB

VXE

VXP

VXR

VXH

VXF

VX3

VXA

VXK21/22/23 Series

For Air / Single Unit

(Non-leak, Medium vacuum)

Model/Valve Specifications

N.C.

N.O.

Symbol

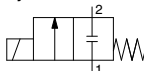

Symbol

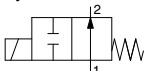

Normally Closed (N.C.)

Port size	Orifice size (mm)	Model	Max. operating pressure differential (MPa)	Flow rate characteristics			Max. system pressure (MPa)	Weight (g)
				C	b	Cv		
1/8 (6A)	2	VXK2110-01	1.5	0.59	0.48	0.18	3.0	480
	3	VXK2120-01	0.6	1.2	0.45	0.33		
	4.5	VXK2130-01	0.2	2.3	0.46	0.61		
1/4 (8A)	2	VXK2110-02	1.5	0.59	0.48	0.18	3.0	640
		VXK2120-02	0.6					
	3	VXK2220-02	1.5	1.2	0.45	0.33		
		VXK2320-02	3.0					
		VXK2130-02	0.2					
	4.5	VXK2230-02	0.35	2.3	0.46	0.61		
		VXK2330-02	0.9					
	6	VXK2240-02	0.15	4.0	0.30	1.10		
		VXK2340-02	0.35					
	8	VXK2250-02	0.08	4.9	0.29	1.20		
	VXK2350-02	0.2						
3/8 (10A)	3	VXK2220-03	1.5	1.2	0.45	0.33	3.0	640
		VXK2320-03	3.0					
	4.5	VXK2230-03	0.35	2.3	0.46	0.61		
		VXK2330-03	0.9					
	6	VXK2240-03	0.15	4.0	0.30	1.10		
		VXK2340-03	0.35					
	8	VXK2250-03	0.08	4.9	0.29	1.20		
		VXK2350-03	0.2					

Note 1) The flow rate characteristics of this product have variations.

When the highly precise flow control is required according to the system to be used, select an orifice diameter 1.3 times larger than that shown above and install a restrictor on the downstream side of the solenoid valve to make the adjustment.

Note 2) Weight of grommet type. Add 10 g for conduit type, 30 g for DIN terminal type, 60 g for conduit terminal type respectively.

Note 3) Refer to "Glossary of Terms" on page 98 for details on the max. operating pressure differential and the max. system pressure.

• If you intend to use any of the solenoid valves at the rated max. operating pressure for the AC spec. with shading coil, please contact SMC beforehand.

Ambient and Fluid Temperature

Fluid temperature (°C)		Ambient temperature (°C)
Solenoid valve option symbol		
NH	V	
-10 (Note) to 60	-10 (Note) to 60	-20 to 60

Note) Dew point temperature: -10°C or less

Fluid: Air

When you operate the VXK series (AC spec.) by air, the built-in full-wave rectifier type is chosen.

• The special construction of the armature reduces abrasion, resulting in a longer service life.

• Noise reduction

Best suited for medical equipment, low-noise environments, etc.



Normally Open (N.O.)

Port size	Orifice size (mm)	Model	Max. operating pressure differential (MPa)	Flow rate characteristics			Max. system pressure (MPa)	Weight (g)
				C	b	Cv		
1/8 (6A)	2	VXK2112-01	1.5	0.59	0.48	0.18	3.0	500
	3	VXK2122-01	0.7	1.2	0.45	0.33		
	4.5	VXK2132-01	0.3	2.3	0.46	0.61		
1/4 (8A)	2	VXK2112-02	1.5	0.59	0.48	0.18	3.0	640
		VXK2122-02	0.7					
	3	VXK2222-02	1.0	1.2	0.45	0.33		
		VXK2322-02	1.6					
		VXK2132-02	0.3					
	4.5	VXK2232-02	0.45	2.3	0.46	0.61		
		VXK2332-02	0.8					
	6	VXK2242-02	0.25	4.0	0.30	1.10		
		VXK2342-02	0.45					
	8	VXK2252-02	0.1	4.9	0.29	1.20		
	VXK2352-02	0.2						
3/8 (10A)	3	VXK2222-03	1.5	1.2	0.45	0.33	3.0	640
		VXK2322-03	1.6					
	4.5	VXK2232-03	0.45	2.3	0.46	0.61		
		VXK2332-03	0.8					
	6	VXK2242-03	0.25	4.0	0.30	1.10		

Note 1) The flow rate characteristics of this product have variations.

When the highly precise flow control is required according to the system to be used, select an orifice diameter 1.3 times larger than that shown above and install a restrictor on the downstream side of the solenoid valve to make the adjustment.

Note 2) Weight of grommet type. Add 10 g for conduit type, 30 g for DIN terminal type, 60 g for conduit terminal type respectively.

Note 3) Refer to "Glossary of Terms" on page 98 for details on the max. operating pressure differential and the max. system pressure.

Valve Leakage

Internal Leakage

Seal material	Leakage rate	
	Air	Non-leak, Medium vacuum (Note)
NBR, FKM	1 cm ³ /min or less	10 ⁻⁶ Pa·m ³ /sec or less

External Leakage

Seal material	Leakage rate	
	Air	Non-leak, Medium vacuum (Note)
NBR, FKM	1 cm ³ /min or less	10 ⁻⁶ Pa·m ³ /sec or less

Note) Value for option "V" (Non-leak, Medium vacuum)



How to Order (Single Unit)

AC VXK 21 2 0 [] [] - 01 [] - 1 G R 1 - []
DC VXK 21 2 0 [] [] - 01 [] - 5 G 1 - []

Model Refer to the Table (1) shown below for availability.
Orifice size Refer to the Table (1) shown below for availability.
Valve/Body configuration

0	N.C./Single unit
2	N.O./Single unit

Solenoid valve option Refer to the Table (2) shown below for availability.

Nil	—
Z	Oil-free

Select nil because the solenoid valve option "V" is the oil-free treatment.
Suffix

Nil	Rc
T	NPTF
F	G
N	NPT

Thread type
Port size Refer to the Table (1) shown below for availability.

1	100 VAC 50/60 Hz	6	12 VDC
2	200 VAC 50/60 Hz	7	240 VAC 50/60 Hz
3	110 VAC 50/60 Hz	8	48 VAC 50/60 Hz
4	220 VAC 50/60 Hz	J	230 VAC 50/60 Hz
5	24 VDC		

Rated voltage
* Refer to the Table (3) shown below for availability.
Refer to page 96 for ordering a coil only.
Bracket

Nil	None
B	With bracket

* Packed in the same container as the main body.
* Refer to the Table (4) when a bracket is ordered separately.
Built-in full-wave rectifier type
Electrical entry
G - Grommet
GS - With grommet surge voltage suppressor
T - With conduit terminal and surge terminal and surge voltage suppressor
TL - With conduit terminal and light
TZ - With conduit terminal, surge voltage suppressor and light
C - Conduit
DS - DIN terminal with surge voltage suppressor
DL - DIN terminal with light
DZ - DIN terminal with surge voltage suppressor and light
DO - For DIN terminal (without connector, gasket is included.)
* DIN type is available with class B only.

- VX2
- VXK**
- VXD
- VXZ
- VXS
- VXB
- VXE
- VXP
- VXR
- VXH
- VXF
- VX3
- VXA

Table (1) Model/Orifice Size/Port Size Normally Closed (N.C.)

Solenoid valve (Port size)			Orifice symbol (Diameter)					
Model	VXK21	VXK22	VXK23	1 (2 mm)	2 (3 mm)	3 (4.5 mm)	4 (6 mm)	5 (8 mm)
Port symbol (Port size)	01 (1/8)	—	—	●	●	●	—	—
	02 (1/4)	—	—	●	●	●	—	—
	—	02 (1/4)	02 (1/4)	—	●	●	●	●
	—	03 (3/8)	03 (3/8)	—	●	●	●	●

Normally Open (N.O.)

Solenoid valve (Port size)			Orifice symbol (Diameter)				
Model	VXK21	VXK22	VXK23	1 (2 mm)	2 (3 mm)	3 (4.5 mm)	4 (6 mm)
Port symbol (Port size)	01 (1/8)	—	—	●	●	●	—
	02 (1/4)	—	—	●	●	●	—
	—	02 (1/4)	02 (1/4)	—	●	●	●
	—	03 (3/8)	03 (3/8)	—	●	●	●

Table (2) Solenoid Valve Option

Option symbol	Seal material	Body material	Coil insulation type	Remarks
Nil	NBR	C37	B	—
V	FKM			Non-leak (10 ⁻⁶ Pa·m ³ /sec), Oil-free, Medium vacuum (0.1 Pa.abs)

* When using with vacuum, consider the max. differential pressure. (0.1 MPa or more is recommended.)



When you operate the **VX series (AC spec.)** by air, the built-in full-wave rectifier type is chosen.
 • The special construction of the armature reduces abrasion, resulting in a longer service life.
 • Noise reduction
 Best suited for medical equipment, low-noise environments, etc.

Table (3) Rated Voltage/Electrical Option

Rated voltage	Class B				
	S	L	Z		
AC/DC	Voltage symbol	Voltage	With surge voltage suppressor	With light	With light and surge voltage suppressor
AC	1	100 V	—	●	—
	2	200 V	—	●	—
	3	110 V	—	●	—
	4	220 V	—	●	—
	7	240 V	—	—	—
	8	48 V	—	—	—
DC	J	230 V	—	—	—
	5	24 V	●	●	●
	6	12 V	●	—	—

* Option "S", "Z" are not available because a surge voltage suppressor is integrated into the AC/Class B, built-in full-wave rectifier type as a standard.

Table (4) Bracket Part No.

Model	Part no.
VXK21	VXK021N-5A
VXK22	
VXK23	

Dimensions → page 95 (Single unit)

VXK21/22/23 Series

For Water /Single Unit

Model/Valve Specifications

N.C.

N.O.

Symbol

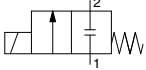

Symbol

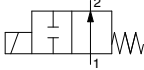

Normally Closed (N.C.)

Port size	Orifice size (mm)	Model	Max. operating pressure differential ^{Note 5)} (MPa)		Note 1) Flow rate characteristics		Note 3) Max. system pressure (MPa)	Note 2) Weight (g)
			AC	DC AC (Built-in full-wave rectifier type)	Kv	Cv converted		
1/8 (6A)	2	VXK2110-01	2.0	1.5	0.15	0.17	480	
	3	VXK2120-01	0.9	0.5	0.28	0.33		
	4.5	VXK2130-01	0.4	0.2	0.54	0.61		
1/4 (8A)	2	VXK2110-02	2.0	1.5	0.15	0.17	3.0	
	3	VXK2120-02	0.9	0.5	0.28	0.33		
		VXK2220-02	1.7	1.5				
		VXK2320-02	2.5	3.0				
	4.5	VXK2130-02	0.4	0.2	0.54	0.61		
		VXK2230-02	0.6	0.35				
		VXK2330-02	0.85	0.9				
	6	VXK2240-02	0.35	0.15	0.82	0.95		
		VXK2340-02	0.55	0.3				
		VXK2250-02	0.13	0.08				
	8	VXK2350-02	0.17	0.2	0.93	1.10		1.0
	3/8 (10A)	3	VXK2220-03	1.7	1.5	0.28		0.33
VXK2320-03			2.5	3.0				
4.5		VXK2230-03	0.6	0.35	0.54	0.61		
		VXK2330-03	0.85	0.9				
		VXK2240-03	0.35	0.15				
6		VXK2240-03	0.55	0.3	0.82	0.95		
		VXK2340-03	0.55	0.3				
		VXK2250-03	0.13	0.08				
8		VXK2350-03	0.17	0.2	0.93	1.10	1.0	

Note 1) The flow rate characteristics of this product have variations.

When the highly precise flow control is required according to the system to be used, select an orifice diameter 1.3 times larger than that shown above and install a restrictor on the downstream side of the solenoid valve to make the adjustment.

Note 2) Weight of grommet type. Add 10 g for conduit type, 30 g for DIN terminal type, and 60 g for conduit terminal type respectively.

Note 3) Refer to "Glossary of Terms" on page 98 for details on the max. operating pressure differential and the max. system pressure.

Normally Open (N.O.)

Port size	Orifice size (mm)	Model	Note 3) Max. operating pressure differential (MPa)		Note 1) Flow rate characteristics		Note 3) Max. system pressure (MPa)	Note 2) Weight (g)
			Kv	Cv converted	Kv	Cv converted		
1/8 (6A)	2	VXK2112-01	0.9	0.15	0.17	500		
	3	VXK2122-01	0.45	0.28	0.33			
	4.5	VXK2132-01	0.2	0.54	0.61			
1/4 (8A)	2	VXK2112-02	0.9	0.15	0.17	3.0		
	3	VXK2122-02	0.45	0.28	0.33			
		VXK2222-02	0.8					
		VXK2322-02	1.2					
	4.5	VXK2132-02	0.2	0.54	0.61			
		VXK2232-02	0.3					
		VXK2332-02	0.6					
	6	VXK2242-02	0.15	0.82	0.95			
		VXK2342-02	0.35					
		VXK2222-03	0.8				0.28	0.33
	3	VXK2322-03	1.2					
	4.5	VXK2232-03	0.3	0.54	0.61			
VXK2332-03		0.6						
VXK2242-03		0.15	0.82			0.95		
6	VXK2342-03	0.35						
3/8 (10A)	3	VXK2222-03		0.8	0.28		0.33	670
	4.5	VXK2232-03	0.3	0.54		0.61		
		VXK2332-03	0.6					
6	VXK2242-03	0.15	0.82	0.95	670			
3/8 (10A)	VXK2342-03	0.35				0.54	0.61	
	VXK2242-03	0.15						0.82
6	VXK2342-03	0.35	0.82	0.95	670			
3/8 (10A)	VXK2242-03	0.15				0.54	0.61	
	VXK2342-03	0.35						0.82
6	VXK2242-03	0.15	0.82	0.95	670			
3/8 (10A)	VXK2342-03	0.35				0.54	0.61	
	VXK2242-03	0.15						0.82
6	VXK2342-03	0.35	0.82	0.95	830			
3/8 (10A)	VXK2242-03	0.15				0.54	0.61	
	VXK2342-03	0.35						0.82

Note 1) The flow rate characteristics of this product have variations.

When the highly precise flow control is required according to the system to be used, select an orifice diameter 1.3 times larger than that shown above and install a restrictor on the downstream side of the solenoid valve to make the adjustment.

Note 2) Weight of grommet type. Add 10 g for conduit type, 30 g for DIN terminal type, and 60 g for conduit terminal type respectively.

Note 3) Refer to "Glossary of Terms" on page 98 for details on the max. operating pressure differential and the max. system pressure.

Ambient and Fluid Temperature

Fluid temperature (°C)		Ambient temperature (°C)
Solenoid valve option symbol		
NH	E	-20 to 60
1 to 60	1 to 99	

Note) With no freezing

Valve Leakage

Internal Leakage

Seal material	Leakage rate (Water)
NBR, EPDM	0.1 cm ³ /min or less

External Leakage

Seal material	Leakage rate (Water)
NBR, EPDM	0.1 cm ³ /min or less



How to Order (Single Unit)

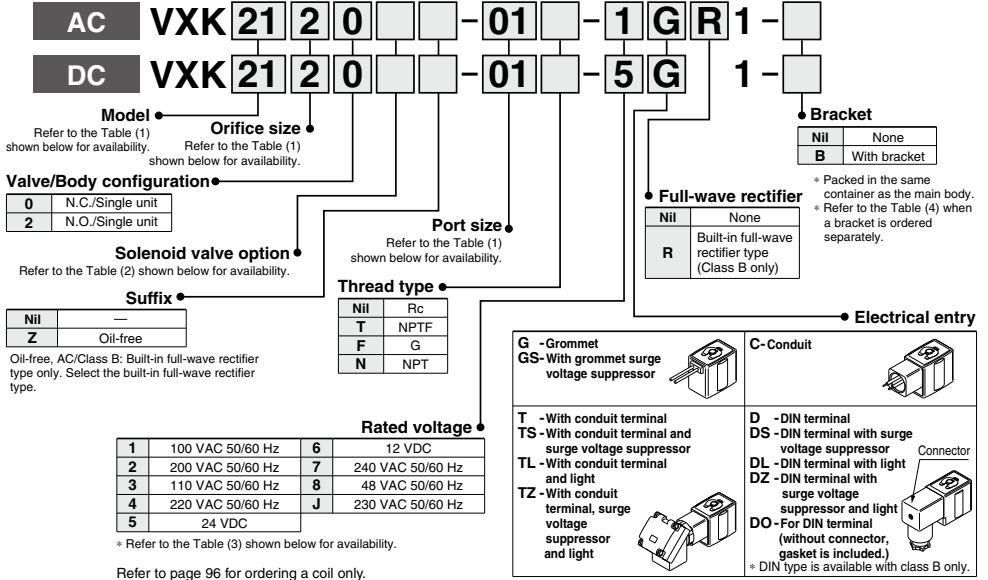

- VX2
- VXK
- VXD
- VXZ
- VXS
- VXB
- VXE
- VXP
- VXR
- VXH
- VXF
- VX3
- VXA

Table (1) Model/Orifice Size/Port Size Normally Closed (N.C.)

Model	Solenoid valve (Port size)			Orifice symbol (Diameter)				
	VXK21	VXK22	VXK23	1 (2 mm)	2 (3 mm)	3 (4.5 mm)	4 (6 mm)	5 (8 mm)
Port symbol (Port size)	01 (1/8)	—	—	●	●	●	—	—
	02 (1/4)	—	—	●	●	●	—	—
	—	02 (1/4)	02 (1/4)	—	●	●	●	●
	—	—	03 (3/8)	—	●	●	●	●

Normally Open (N.O.)

Model	Solenoid valve (Port size)			Orifice symbol (Diameter)			
	VXK21	VXK22	VXK23	1 (2 mm)	2 (3 mm)	3 (4.5 mm)	4 (6 mm)
Port symbol (Port size)	01 (1/8)	—	—	●	●	●	—
	02 (1/4)	—	—	●	●	●	—
	—	02 (1/4)	02 (1/4)	—	●	●	●
	—	—	03 (3/8)	—	●	●	●

Table (3) Rated Voltage/Electrical Option

Rated voltage			Class B			Class H		
AC/DC	Voltage symbol	Voltage	With surge voltage suppressor	With light	With light/surge voltage suppressor	With surge voltage suppressor	With light	With light/surge voltage suppressor
AC	1	100 V	●	●	●	●	●	●
	2	200 V	●	●	●	●	●	●
	3	110 V	●	●	●	●	●	●
	4	220 V	●	●	●	●	●	●
	7	240 V	●	—	—	●	—	—
	8	48 V	●	—	—	●	—	—
DC	J	230 V	●	—	—	●	—	—
	5	24 V	●	●	●	DC spec. is not available.		
	6	12 V	●	—	—	DC spec. is not available.		

* Option "S", "Z" are not available because a surge voltage suppressor is integrated into the AC/Class B, built-in full-wave rectifier type as a standard.

Table (2) Solenoid Valve Option

Option symbol	Seal material	Body/Shading coil material	Coil insulation type	Remarks
Nil	NBR	C37/Cu	B	—
E	EPDM		H	Heated water (AC only)

Table (4) Bracket Part No.

Model	Part no.
VXK21	VXK021N-5A
VXK22	
VXK23	

Dimensions → page 95 (Single unit)



For Oil /Single Unit

Model/Valve Specifications

N.C.

N.O.

Symbol

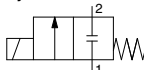

Symbol



Normally Closed (N.C.)

Port size	Orifice size (mm)	Model	Max. operating pressure differential ^{Note 3)} (MPa)		Flow rate characteristics ^{Note 1)}		Max. system pressure (MPa) ^{Note 3)}	Weight (g) ^{Note 2)}
			AC	DC (Built-in full-wave rectifier type)	Kv	Cv converted		
1/8 (6A)	2	VXK2110-01	1.5	1.5	0.15	0.17	480	
	3	VXK2120-01	0.5	0.5	0.28	0.33		
	4.5	VXK2130-01	0.2	0.15	0.54	0.61		
1/4 (8A)	2	VXK2110-02	1.5	1.5	0.15	0.17	3.0	
	3	VXK2120-02	0.5	0.5	0.28	0.33		
		VXK2220-02	1.2	1.2				
	4.5	VXK2320-02	1.7	2.0	0.54	0.61		
		VXK2130-02	0.2	0.15				
	6	VXK2230-02	0.35	0.3	0.82	0.95		
		VXK2330-02	0.55	0.85				
	8	VXK2240-02	0.2	0.1	0.93	1.10		
		VXK2340-02	0.35	0.3				
	3/8 (10A)	3	VXK2250-02	0.1	0.08	0.93		1.10
VXK2350-02			0.14	0.2				
4.5		VXK2220-03	1.2	1.2	0.28	0.33		
		VXK2320-03	1.7	2.0				
6		VXK2230-03	0.35	0.3	0.54	0.61		
		VXK2330-03	0.55	0.85				
8		VXK2240-03	0.2	0.1	0.82	0.95		
		VXK2340-03	0.35	0.3				
6	VXK2250-03	0.1	0.08	0.93	1.10			
	VXK2350-03	0.14	0.2					

Note 1) The flow rate characteristics of this product have variations.

When the highly precise flow control is required according to the system to be used, select an orifice diameter 1.3 times larger than that shown above and install a restrictor on the downstream side of the solenoid valve to make the adjustment.

Note 2) Weight of grommet type. Add 10 g for conduit type, 30 g for DIN terminal type, and 60 g for conduit terminal type respectively.

Note 3) Refer to "Glossary of Terms" on page 98 for details on the max. operating pressure differential and the max. system pressure.

Normally Open (N.O.)

Port size	Orifice size (mm)	Model	Max. operating pressure differential ^{Note 3)} (MPa)		Flow rate characteristics ^{Note 1)}		Max. system pressure (MPa) ^{Note 3)}	Weight (g) ^{Note 2)}
			AC, DC	Kv	Cv converted			
						AC, DC		
1/8 (6A)	2	VXK2112-01	0.8	0.15	0.17	500		
	3	VXK2122-01	0.45	0.28	0.33			
	4.5	VXK2132-01	0.2	0.54	0.61			
1/4 (8A)	2	VXK2122-02	0.8	0.15	0.17	3.0		
	3	VXK2122-02	0.45	0.28	0.33			
		VXK2222-02	0.7					
	4.5	VXK2322-02	1.0	0.54	0.61			
		VXK2132-02	0.2					
	6	VXK2232-02	0.3	0.82	0.95			
		VXK2332-02	0.6					
	8	VXK2242-02	0.15	0.93	1.10			
		VXK2342-02	0.35					
	3/8 (10A)	3	VXK2222-03	0.7	0.28		0.33	
4.5		VXK2322-03	1.0	0.54	0.61			
		VXK2232-03	0.3					
6		VXK2332-03	0.6	0.82	0.95			
		VXK2242-03	0.15					
8	VXK2342-03	0.35	0.93	1.10				

Note 1) The flow rate characteristics of this product have variations.

When the highly precise flow control is required according to the system to be used, select an orifice diameter 1.3 times larger than that shown above and install a restrictor on the downstream side of the solenoid valve to make the adjustment.

Note 2) Weight of grommet type. Add 10 g for conduit type, 30 g for DIN terminal type, and 60 g for conduit terminal type respectively.

Note 3) Refer to "Glossary of Terms" on page 98 for details on the max. operating pressure differential and the max. system pressure.

Ambient and Fluid Temperature

Fluid temperature (°C)		Ambient temperature (°C)
Solenoid valve option symbol		
A	D	
-5 ^{Note)} to 60	-5 ^{Note)} to 120	-20 to 60

Note) Dynamic viscosity: 50 mm²/s or less

Valve Leakage

Internal Leakage

Seal material	Leakage rate (Oil)
FKM	0.1 cm ³ /min or less

External Leakage

Seal material	Leakage rate (Oil)
FKM	0.1 cm ³ /min or less

Direct Operated 2 Port Solenoid Valve with Built-in Y-strainer **VXK21/22/23 Series**

For Oil/Single Unit



How to Order (Single Unit)

AC VXK 21 2 0 A - 01 - 1 GR 1 -

DC VXK 21 2 0 A - 01 - 5 G 1 -

Model Refer to the Table (1) shown below for availability.

Orifice size Refer to the Table (1) shown below for availability.

Valve/Body configuration

0	N.C./Single unit
2	N.O./Single unit

Solenoid valve option Refer to the Table (2) shown below for availability.

Suffix

Nil	—
Z	Oil-free

Oil-free, AC/Class B: Built-in full-wave rectifier type only. Select the built-in full-wave rectifier type.

Thread type

Nil	Rc
T	NPTF
F	G
N	NPT

Rated voltage

1	100 VAC 50/60 Hz	6	12 VDC
2	200 VAC 50/60 Hz	7	240 VAC 50/60 Hz
3	110 VAC 50/60 Hz	8	48 VAC 50/60 Hz
4	220 VAC 50/60 Hz	J	230 VAC 50/60 Hz
5	24 VDC		

* Refer to the Table (3) shown below for availability.

Refer to page 96 for ordering a coil only.

Bracket

Nil	None
B	With bracket

* Packed in the same container as the main body.

* Refer to the Table (4) when a bracket is ordered separately.

Full-wave rectifier

Nil	None
R	Built-in full-wave rectifier type (Class B only)

Electrical entry

G - Grommet
GS - With grommet surge voltage suppressor

C - Conduit

T - With conduit terminal
TS - With conduit terminal and surge voltage suppressor
TL - With conduit terminal and light
TZ - With conduit terminal, surge voltage suppressor and light

D - DIN terminal
DS - DIN terminal with surge voltage suppressor
DL - DIN terminal with light
DZ - DIN terminal with surge voltage suppressor and light
DO - For DIN terminal (without connector, gasket is included.)

Connector

* DIN type is available with class B only.

- VX2
- VXK**
- VXD
- VXZ
- VXS
- VXB
- VXE
- VXP
- VXR
- VXH
- VXF
- VX3
- VXA

Table (1) Model/Orifice Size/Port Size

Normally Closed (N.C.)

Solenoid valve (Port size)			Orifice symbol (Diameter)					
Model	VXK21	VXK22	VXK23	1 (2 mm)	2 (3 mm)	3 (4.5 mm)	4 (6 mm)	5 (8 mm)
Port symbol (Port size)	01 (1/8)	—	—	●	●	●	—	—
	02 (1/4)	—	—	●	●	●	—	—
	—	02 (1/4)	02 (1/4)	—	●	●	●	—
	—	—	03 (3/8)	—	●	●	●	●

Normally Open (N.O.)

Solenoid valve (Port size)			Orifice symbol (Diameter)				
Model	VXK21	VXK22	VXK23	1 (2 mm)	2 (3 mm)	3 (4.5 mm)	4 (6 mm)
Port symbol (Port size)	01 (1/8)	—	—	●	●	●	—
	02 (1/4)	—	—	●	●	●	—
	—	02 (1/4)	02 (1/4)	—	●	●	●
	—	—	03 (3/8)	—	●	●	●

Table (3) Rated Voltage/Electrical Option

Rated voltage			Class B			Class H		
AC/DC	Voltage symbol	Voltage	S With surge voltage suppressor	L With light	Z With light/surge voltage suppressor	S With surge voltage suppressor	L With light	Z With light/surge voltage suppressor
AC	1	100 V	●	●	●	●	●	●
	2	200 V	●	●	●	●	●	●
	3	110 V	●	●	●	●	●	●
	4	220 V	●	●	●	●	●	●
	7	240 V	●	—	—	●	—	—
	8	48 V	●	—	—	●	—	—
	J	230 V	●	—	—	●	—	—
DC	5	24 V	●	—	●	DC spec. is not available.		
	6	12 V	●	—	—	DC spec. is not available.		

* Option "S", "Z" are not available because a surge voltage suppressor is integrated into the AC/Class B, built-in full-wave rectifier type as a standard.

Table (2) Solenoid Valve Option

Option symbol	Seal material	Body/Shading coil material	Coil insulation type
A	FKM	C37/Cu	B
D			H

The additives contained in oil are different depending on the type and manufacturers, so the durability of the seal materials will vary. For details, please consult with SMC.

Table (4) Bracket Part No.

Model	Part no.
VXK21	VXK021N-5A
VXK22	
VXK23	

Dimensions → page 95 (Single unit)

VXK21/22/23 Series

For Steam /Single Unit

Model/Valve Specifications

N.C.

N.O.

Symbol

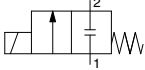

Symbol

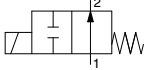

Normally Closed (N.C.)

Port size	Orifice size (mm)	Model	Note 1) Flow rate characteristics			Note 3) Max. system pressure (MPa)	Note 2) Weight (g)	
			AC	Kv	Cv converted			
1/8 (6A)	2	VXK2110-01	1.0	0.15	0.17	1.0	480	
	3	VXK2120-01	1.0	0.28	0.33			
	4.5	VXK2130-01	0.45	0.54	0.61			
1/4 (8A)	2	VXK2110-02	1.0	0.15	0.17			
	3	VXK2120-02	1.0	0.28	0.33			
	4.5	VXK2130-02	0.45	0.54	0.61			
		VXK2230-02	0.75					
	6	VXK2240-02	0.4	0.82	0.95			
		VXK2340-02	0.5					
	8	VXK2250-02	0.15	0.93	1.10			
		VXK2350-02	0.2					
	3/8 (10A)	3	VXK2220-03	1.0	0.28			0.33
		4.5	VXK2230-03	0.75	0.54	0.61		
VXK2330-03			1.0					
6		VXK2240-03	0.4	0.82	0.95			
		VXK2340-03	0.5					
8		VXK2250-03	0.15	0.93	1.10			
		VXK2350-03	0.2					

Note 1) The flow rate characteristics of this product have variations.

When the highly precise flow control is required according to the system to be used, select an orifice diameter 1.3 times larger than that shown above and install a restrictor on the downstream side of the solenoid valve to make the adjustment.

Note 2) Weight of grommet type. Add 60 g for conduit terminal type.

Note 3) Refer to "Glossary of Terms" on page 98 for details on the max. operating pressure differential and the max. system pressure.

Normally Open (N.O.)

Port size	Orifice size (mm)	Model	Note 1) Flow rate characteristics			Note 3) Max. system pressure (MPa)	Note 2) Weight (g)
			AC	Kv	Cv converted		
1/8 (6A)	2	VXK2112-01	1.0	0.15	0.17	1.0	500
	3	VXK2122-01	0.7	0.28	0.33		
	4.5	VXK2132-01	0.3	0.54	0.61		
1/4 (8A)	2	VXK2112-02	1.0	0.15	0.17		
	3	VXK2122-02	0.7	0.28	0.33		
	VXK2222-02	1.0					
	4.5	VXK2132-02	0.3	0.54	0.61		
		VXK2232-02	0.45				
	6	VXK2332-02	0.8	0.82	0.95		
		VXK2242-02	0.25				
	8	VXK2342-02	0.45	0.93	1.10		
		VXK2252-02	0.2				
	3/8 (10A)	3	VXK2222-03	1.0	0.28	0.33	1.0
4.5		VXK2232-03	0.45	0.54	0.61		
		VXK2332-03	0.8				
6		VXK2242-03	0.25	0.82	0.95		
		VXK2342-03	0.45				

Note 1) The flow rate characteristics of this product have variations.

When the highly precise flow control is required according to the system to be used, select an orifice diameter 1.3 times larger than that shown above and install a restrictor on the downstream side of the solenoid valve to make the adjustment.

Note 2) Weight of grommet type. Add 60 g for conduit terminal type.

Note 3) Refer to "Glossary of Terms" on page 98 for details on the max. operating pressure differential and the max. system pressure.

Ambient and Fluid Temperature

Max. fluid temperature (°C)	Ambient temperature (°C)
Solenoid valve option symbol	
S	

183 -20 to 60

Valve Leakage

Internal Leakage

Seal material	Leakage rate (Air)
PTFE	300 cm ³ /min or less

External Leakage

Seal material	Leakage rate (Air)
PTFE	1 cm ³ /min or less



How to Order (Single Unit)

AC VXK 21 2 0 S - 01 - 1 G 1 -

Model
Refer to the Table (1) shown below for availability.

Orifice size
Refer to the Table (1) shown below for availability.

Valve/Body configuration

0	N.C./Single unit
2	N.O./Single unit

Solenoid valve option
Refer to the Table (2) shown below for availability.

Suffix

Nil	—
Z	Oil-free

Port size
Refer to the Table (1) shown below for availability.

Thread type

Nil	Rc
T	NPTF
F	G
N	NPT

Rated voltage

1	100 VAC 50/60 Hz	7	240 VAC 50/60 Hz
2	200 VAC 50/60 Hz	8	48 VAC 50/60 Hz
3	110 VAC 50/60 Hz	J	230 VAC 50/60 Hz
4	220 VAC 50/60 Hz		

* Refer to the Table (3) shown below for availability.

Refer to page 96 for ordering a coil only.

Bracket

Nil	None
B	With bracket

* Packed in the same container as the main body.
* Refer to the Table (4) when a bracket is ordered separately.

Electrical entry

C-Conduit

G -Grommet
GS- With grommet surge voltage suppressor

T -With conduit terminal
TS- With conduit terminal and surge voltage suppressor
TL -With conduit terminal and light
TZ -With conduit terminal, surge voltage suppressor and light

* Refer to the Table (3) for the available combinations between each electrical option (S, L, Z) and rated voltage.

- VX2
- VXK
- VXD
- VXZ
- VXS
- VXB
- VXE
- VXP
- VXR
- VXH
- VXF
- VX3
- VXA

Table (1) Model/Orifice Size/Port Size
Normally Closed (N.C.)

Solenoid valve (Port size)			Orifice symbol (Diameter)					
Model	VXK21	VXK22	VXK23	1 (2 mmø)	2 (3 mmø)	3 (4.5 mmø)	4 (6 mmø)	5 (8 mmø)
Port symbol (Port size)	01 (1/8)	—	—	●	●	●	—	—
	02 (1/4)	—	—	●	●	●	—	—
	—	02 (1/4)	02 (1/4)	—	—	●	●	●
—	03 (3/8)	03 (3/8)	—	● (VXK22)	●	●	●	●

Normally Open (N.O.)

Solenoid valve (Port size)			Orifice symbol (Diameter)				
Model	VXK21	VXK22	VXK23	1 (2 mmø)	2 (3 mmø)	3 (4.5 mmø)	4 (6 mmø)
Port symbol (Port size)	01 (1/8)	—	—	●	●	●	—
	02 (1/4)	—	—	●	●	●	—
	—	02 (1/4)	02 (1/4)	—	● (VXK22)	●	●
—	03 (3/8)	03 (3/8)	—	● (VXK22)	●	●	

Table (2) Solenoid Valve Option

Option symbol	Seal material	Body/Shading coil material	Coil insulation type
S	PTFE	C37/Cu	H

Solenoid coil: AC/Class H only

Table (3) Rated Voltage/Electrical Option

Rated voltage		Class H			
AC/DC	Voltage symbol	Voltage	S With surge voltage suppressor	L With light	Z With light/surge voltage suppressor
AC	1	100 V	●	●	●
	2	200 V	●	●	●
	3	110 V	●	●	●
	4	220 V	●	●	●
	7	240 V	●	—	—
	8	48 V	●	—	—
	J	230 V	●	—	—
DC	5	24 V	DC spec. is not available.		
	6	12 V	DC spec. is not available.		

Table (4) Bracket Part No.

Model	Part no.
VXK21	VXK021N-5A
VXK22	
VXK23	

Dimensions → page 95 (Single unit)

VXK21/22/23 Series

For Air, Water, Oil, Steam

Construction: Single Unit

Normally closed (N.C.)

Body material: C37

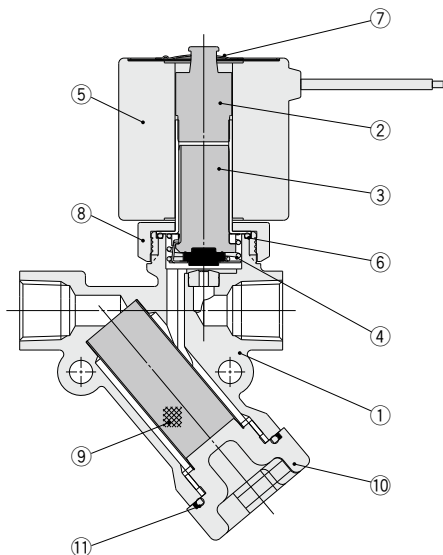

Normally open (N.O.)

Body material: C37

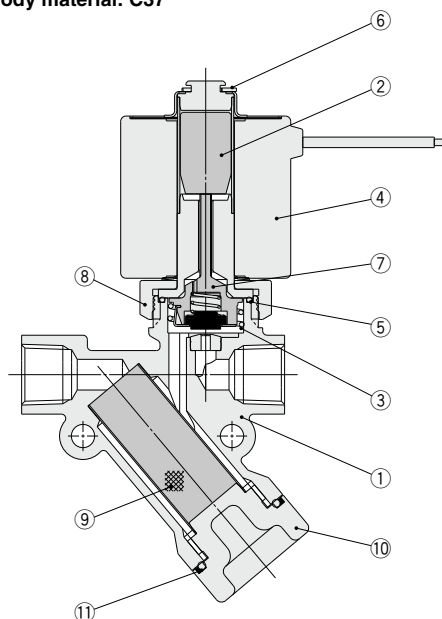

Component Parts

No.	Description	Material
1	Body	C37
2	Tube assembly ^{Note 2)}	Stainless steel, Cu
3	Armature assembly	Stainless steel, PPS, NBR (FKM, EPDM, PTFE)
4	Return spring	Stainless steel
5	Solenoid coil	—
6	O-ring	NBR (FKM, EPDM, PTFE)
7	Clip	SK
8	Nut	C37
9	Strainer	Stainless steel
10	Plug	C37
11	O-ring	NBR (FKM, EPDM, PTFE)

Note 1) The seal materials shown in () are available depending on the option selected.

Note 2) "Cu" is not available with the DC spec. and AC spec. built-in full-wave rectifier type.

Component Parts

No.	Description	Material
1	Body	C37
2	Tube assembly ^{Note 2)}	Stainless steel, Cu
3	Return spring	Stainless steel
4	Solenoid coil	—
5	O-ring	NBR (FKM, EPDM, PTFE)
6	E stop ring	Stainless steel
7	Push rod assembly	Stainless steel, PPS, NBR (FKM, EPDM, PTFE)
8	Nut	C37
9	Strainer	Stainless steel
10	Plug	C37
11	O-ring	NBR (FKM, EPDM, PTFE)

Note 1) The seal materials shown in () are available depending on the option selected.

Note 2) "Cu" is not available with the DC spec. and AC spec. built-in full-wave rectifier type.

Dimensions

Normally closed (N.C.): VXK21□0/VXK22□0/VXK23□0

Normally open (N.O.): VXK21□2/VXK22□2/VXK23□2

Grommet: G

Conduit: C

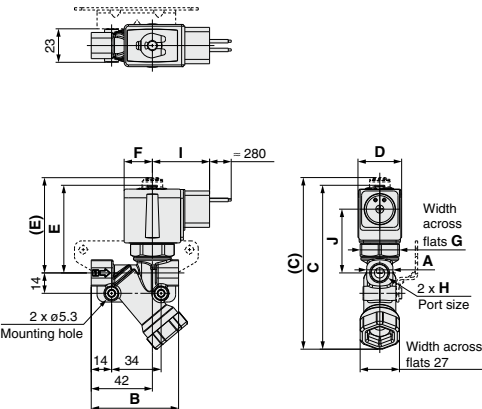
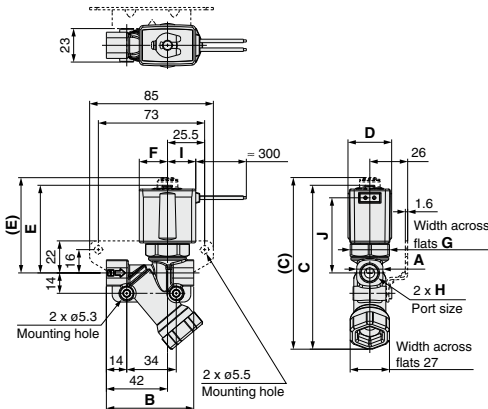

DIN terminal: D

Conduit terminal: T

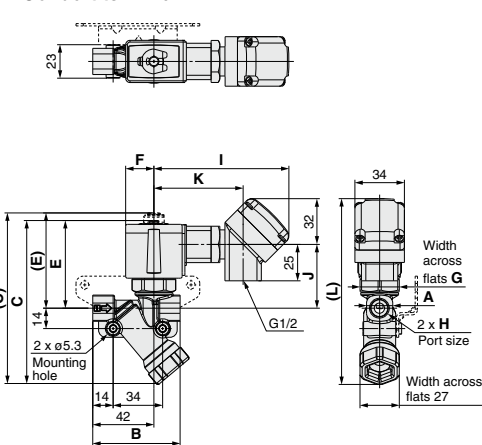
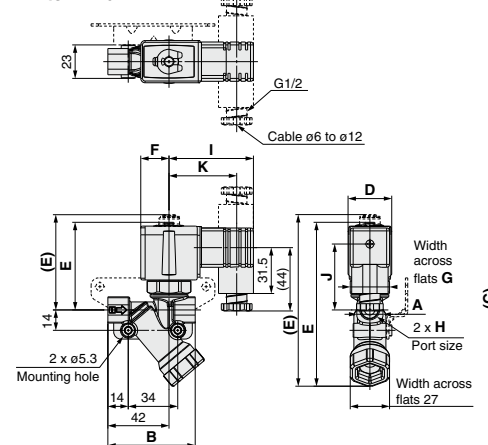

(mm)

Model		Orifice size	Port size H	A	B	C	(C)	D	E	(E)	F	G
Normally closed (N.C.)	Normally open (N.O.)											
VXK21□0	VXK21□2	ø2, ø3, ø4.5	1/8, 1/4	18	60	(112)	(119)	30	60	67	19.5	27
VXK22□0	VXK22□2	ø3, ø4.5, ø6, ø8 (Note 1)	1/4, 3/8	22	63.5	(121.5)	(128.5)	35	69	76.5	22.5	32
VXK23□0	VXK23□2	ø3, ø4.5, ø6, ø8 (Note 1)	1/4, 3/8	22	63.5	(127.5)	(136)	40	75.5	83.5	25	36

Model		Orifice size	Port size H	Electrical entry (Note 3)								Built-in full-wave rectifier type Electrical entry (Note 3)													
Normally closed (N.C.)	Normally open (N.O.)			Grommet	Conduit		DIN terminal		Conduit terminal		Grommet	Conduit		DIN terminal		Conduit terminal									
				I	J	I	J	I	J	K	I	J	K	L	I	J	I	J	K	L					
VXK21□0	VXK21□2	ø2, ø3, ø4.5	1/8, 1/4	19.5	52	40	44.5	58.5	44	46.5	(92)	44.5	(61)	(129)	30	48	48.5	43	65.5	44	53.5	(100.5)	43	(69.5)	(127)
VXK22□0	VXK22□2	ø3, ø4.5, ø6, ø8 (Note 1)	1/4, 3/8	22.5	61	43	53.5	61.5	53	49.5	(95)	53.5	(64)	(138)	33	57	51.5	52	68.5	53	56.5	(103.5)	52	(72.5)	(136.5)
VXK23□0	VXK23□2	ø3, ø4.5, ø6, ø8 (Note 1)	1/4, 3/8	25.5	67.5	46	60	64	59.5	52	(98)	60	(66.5)	(143.5)	36	63.5	54	58.5	71	59.5	59	(106)	58.5	(75)	(142.5)

Note 1) An orifice size of ø8 is only available with the N.C. spec.
 Note 2) (C)(E): N.O. spec. dimensions
 Note 3) Add 1.5 mm to 'J' and 'L' dimensions for the N.O. spec.

- VX2
- VXK**
- VXD
- VXZ
- VXS
- VXB
- VXE
- VXP
- VXR
- VXH
- VXF
- VX3
- VXA

VXK21/22/23 Series

For Air, Water, Oil, Steam

Replacement Parts

● Solenoid Coil Assembly Part No.

VX02 **1**N-**1**G-□-□

Model

1	VXK21□□
2	VXK22□□
3	VXK23□□

Valve

Nil	N.C.
2	N.O.

Rated voltage ^{Note}

1	100 VAC 50/60 Hz
2	200 VAC 50/60 Hz
3	110 VAC 50/60 Hz
4	220 VAC 50/60 Hz
5	24 VDC
6	12 VDC
7	240 VAC 50/60 Hz
8	48 VAC 50/60 Hz
J	230 VAC 50/60 Hz



Coil insulation type ^{Note}

Nil	Class B
H*	Class H

* DIN terminal and DC spec. are not available.

Note) Refer to the Table (1) for the available combinations.

Electrical entry

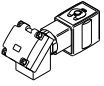
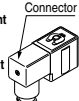
G - Grommet GS - With grommet surge voltage suppressor 	C - Conduit 
T - With conduit terminal TS - With conduit terminal and surge voltage suppressor TL - With conduit terminal and light TZ - With conduit terminal, surge voltage suppressor and light 	D - DIN terminal DS - DIN terminal with surge voltage suppressor DL - DIN terminal with light DZ - DIN terminal with surge voltage suppressor and light DO - For DIN terminal (without connector)  * DIN type is available with class B only.

* Refer to the Table (1) for the available combinations between each electrical option (S, L, Z) and rated voltage.

● DIN Connector Part No.

Without electrical option **GDM2A**

With electrical option **GDM2A**-□□

Electrical option

S	With surge voltage suppressor
L	With light
Z	With light/surge voltage suppressor

* Refer to the Table (1) for the available combinations between each electrical option (S, L, Z) and rated voltage.

Rated voltage

1	100 VAC, 110 VAC
2	200 VAC, 220 VAC, 230 VAC, 240 VAC
5	24 VDC
6	12 VDC
15	48 VAC

● Gasket Part No. for DIN Connector

VCW20-1-29-1

AC/Class B (Built-in full-wave rectifier)

VX02 **1**N-**1**GR-□

Model

1	VXK21□□
2	VXK22□□
3	VXK23□□

Valve



Nil	N.C.
2	N.O.

Rated voltage ^{Note}

1	100 VAC 50/60 Hz
2	200 VAC 50/60 Hz
3	110 VAC 50/60 Hz
4	220 VAC 50/60 Hz
7	240 VAC 50/60 Hz
8	48 VAC 50/60 Hz
J	230 VAC 50/60 Hz

Note) Refer to the Table (1) for the available combinations.

Electrical entry

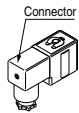
G - Grommet 	C - Conduit 
T - With conduit terminal TL - With conduit terminal and light 	D - DIN terminal DL - DIN terminal with light DO - For DIN terminal (without connector, gasket is included.) 

* Refer to the Table (1) for the available combinations between each electrical option and rated voltage.

* Surge voltage suppressor is integrated into the AC/Class B, built-in full-wave rectifier type as a standard.

Table (1) Rated Voltage/Electrical Option

AC/DC	Rated voltage		Class B			Class H		
	Voltage symbol	Voltage	With surge voltage suppressor	With light	With light/surge voltage suppressor	With surge voltage suppressor	With light	With light/surge voltage suppressor
AC	1	100 V	●	●	●	●	●	●
	2	200 V	●	●	●	●	●	●
	3	110 V	●	●	●	●	●	●
	4	220 V	●	●	●	●	●	●
	7	240 V	●	—	—	—	—	—
	8	48 V	●	—	—	●	—	—
	J	230 V	●	—	—	●	—	—
DC	5	24 V	●	●	●	DC spec. is not available.		
	6	12 V	●	—	—	DC spec. is not available.		

* Option "S", "Z" are not available because a surge voltage suppressor is integrated into the AC/Class B, built-in full-wave rectifier type as a standard.

* Replacement of solenoid coil

• Cannot be changed between DC and AC.

• Cannot be changed between DC and AC (built-in full-wave rectifier type).

• Can be changed from DC to DC.

• Can be changed from AC to AC.

● Name Plate Part No.

AZ-T- Valve model

↑ Enter by referring to "How to Order" (Single Unit).

● Clip Part No. (For N.C.)

For VX21: **VX021N-10**

For VX22: **VX022N-10**

For VX23: **VX023N-10**

● Clip Part No. (For N.O.)

For VX21: **ETW-7**

For VX22: **ETW-8**

For VX23: **ETW-9**

● Strainer Part No.

Strainer	VXK021N-4-1
Plug assembly (Plug + O-ring)	VXK021N-3CA (NBR) VXK021N-3CA-F (FKM) VXK021N-3CA-E (EPDM) VXK021N-3CA-P (PTFE)
O-ring <small>* Part numbers are for a set of ten O-rings.</small>	VXK-OR (NBR) VXK-OR-F (FKM) VXK-OR-E (EPDM) VXK-OR-P (PTFE)

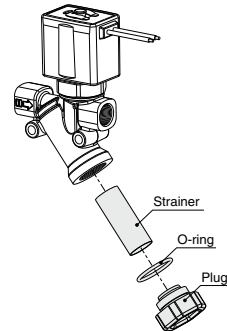
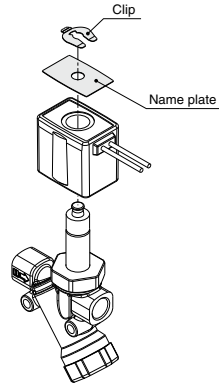

VX2

VXK

VXD

VXZ

VXS

VXB

VXE

VXP

VXR

VXH

VXF

VX3

VXA

VXK21/22/23 Series

Glossary of Terms

Pressure Terminology

1. Maximum operating pressure differential

The maximum pressure differential (the difference between the inlet and outlet pressure) which is allowed for operation. When the outlet pressure is 0 MPa, this becomes the maximum operating pressure.

2. Minimum operating pressure differential

The minimum pressure differential (the difference between the inlet pressure and outlet pressure) required to keep the main valve stably operating.

3. Maximum system pressure

The maximum pressure that can be applied inside the pipelines (line pressure).
(The pressure differential of the solenoid valve portion must be less than the maximum operating pressure differential.)

4. Proof pressure

The pressure in which the valve must be withstood without a drop in performance after holding for one minute under prescribed pressure and returning to the operating pressure range. (value under the prescribed conditions)

5. 100 mesh

The number of meshes over a length of 25.4 mm (1 inch).

Electrical Terminology

1. Apparent power (VA)

Volt-ampere is the product of voltage (V) and current (A).
Power consumption (W): For AC, $W = V \cdot A \cdot \cos\theta$. For DC, $W = V \cdot A$.
(Note) $\cos\theta$ shows power factor. $\cos\theta = 0.6$

2. Surge voltage

A high voltage which is momentarily generated by shutting off the power in the shut-off area.

3. Enclosure

A degree of protection defined in the "JIS C 0920: Waterproof test of electric machinery/appliance and the degree of protection against the intrusion of solid foreign objects".

Verify the degree of protection for each product.

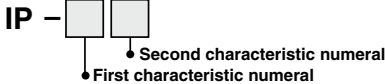

● First Characteristics:

Degrees of protection against solid foreign objects

0	Non-protected
1	Protected against solid foreign objects of 50 mm ϕ and greater
2	Protected against solid foreign objects of 12 mm ϕ and greater
3	Protected against solid foreign objects of 2.5 mm ϕ and greater
4	Protected against solid foreign objects of 1.0 mm ϕ and greater
5	Dust-protected
6	Dusttight

● Second Characteristics:

Degrees of protection against water

0	Non-protected	—
1	Protected against vertically falling water drops	Dripproof type 1
2	Protected against vertically falling water drops when enclosure tilted up to 15°	Dripproof type 2
3	Protected against rainfall when enclosure tilted up to 60°	Rainproof type
4	Protected against splashing water	Splashproof type
5	Protected against water jets	Low jetproof type
6	Protected against powerful water jets	Strong jetproof type
7	Protected against the effects of temporary immersion in water	Immersion type
8	Protected against the effects of continuous immersion in water	Submersible type

Example) IP65: Dusttight, Low jetproof type

"Low jetproof type" means that no water intrudes inside an equipment that could hinder from operating normally by means of applying water for 3 minutes in the prescribed manner. Take appropriate protection measures, since a device is not usable in an environment where a droplet of water is splashed constantly.

Others

1. Material

NBR: Nitrile rubber
FKM: Fluororubber
EPDM: Ethylene propylene rubber
PTFE: Polytetrafluoroethylene resin

2. Oil-free treatment

The degreasing and washing of wetted parts.

3. Symbol

In the symbol (□□□□□) Port 1 (IN) and Port 2 (OUT) are shown in a blocked condition (⊘), but it is not possible to use the valve in cases of reverse pressure, where the Port 2 pressure is higher than the Port 1 pressure.

Solenoid Valve Flow Rate Characteristics (How to indicate flow rate characteristics)

1. Indication of flow rate characteristics

The flow rate characteristics in equipment such as a solenoid valve, etc. are indicated in their specifications as shown in Table (1).

Table (1) Indication of Flow Rate Characteristics

Corresponding equipment	Indication by international standard	Other indications	Conformed standard
Pneumatic equipment	<i>C, b</i>	—	ISO 6358: 1989 JIS B 8390: 2000
	—	<i>S</i>	JIS B 8390: 2000 Equipment: JIS B 8379, 8381-1, 8381-2
	—	<i>Cv</i>	ANSI/(NFPA)T3.21.3 R1-2008
Process fluid control equipment	<i>Kv</i>	—	IEC60534-1: 2005 IEC60534-2-3: 1997 JIS B 2005-1: 2012
	—	<i>Cv</i>	JIS B 2005-2-3: 2004 Equipment: JIS B 8471, 8472, 8473

2. Pneumatic equipment

2.1 Indication according to the international standards

(1) Conformed standard

ISO 6358: 1989 : Pneumatic fluid power—Components using compressible fluids—
Determination of flow rate characteristics

JIS B 8390: 2000 : Pneumatic fluid power—Components using compressible fluids—
How to test flow rate characteristics

(2) Definition of flow rate characteristics

The flow rate characteristics are indicated as a result of a comparison between sonic conductance **C** and critical pressure ratio **b**.

Sonic conductance **C** : Value which divides the passing mass flow rate of an equipment in a choked flow condition by the product of the upstream absolute pressure and the density in a standard condition.

Critical pressure ratio **b** : Pressure ratio (downstream pressure/upstream pressure) which will turn to a choked flow when the value is smaller than this ratio.

Choked flow : The flow in which the upstream pressure is higher than the downstream pressure and where sonic speed in a certain part of an equipment is reached.

Gaseous mass flow rate is in proportion to the upstream pressure and not dependent on the downstream pressure.

Subsonic flow : Flow greater than the critical pressure ratio

Standard condition : Air in a temperature state of 20°C, absolute pressure 0.1 MPa (= 100 kPa = 1 bar), relative humidity 65%.

It is stipulated by adding the “(ANR)” after the unit depicting air volume.

(standard reference atmosphere)

Conformed standard: ISO 8778: 1990 Pneumatic fluid power—Standard reference

atmosphere, JIS B 8393: 2000: Pneumatic fluid power—Standard reference atmosphere

(3) Formula for flow rate

It is described by the practical units as following.

When

$$\frac{P_2 + 0.1}{P_1 + 0.1} \leq b, \text{ choked flow}$$

$$Q = 600 \times C (P_1 + 0.1) \sqrt{\frac{293}{273 + T}} \dots\dots\dots(1)$$

When

$$\frac{P_2 + 0.1}{P_1 + 0.1} > b, \text{ subsonic flow}$$

$$Q = 600 \times C (P_1 + 0.1) \sqrt{1 - \left[\frac{P_2 + 0.1}{P_1 + 0.1} - b \right]^2} \sqrt{\frac{293}{273 + T}} \dots\dots\dots(2)$$

- VX2
- VXK**
- VXD
- VXZ
- VXS
- VXB
- VXE
- VXP
- VXR
- VXH
- VXF
- VX3
- VXA

VXK21/22/23 Series

- Q** : Air flow rate [L/min (ANR)]
- C** : Sonic conductance [dm³/(s·bar)], dm³ (Cubic decimeter) of SI = L (liter).
- b** : Critical pressure ratio [—]
- P₁** : Upstream pressure [MPa]
- P₂** : Downstream pressure [MPa]
- T** : Temperature [°C]

Note) Formula of subsonic flow is the elliptic analogous curve.
 Flow rate characteristics are shown in Graph (1) For details, please use the calculation software available from SMC website.

Example)

Obtain the air flow rate for **P₁** = 0.4 [MPa], **P₂** = 0.3 [MPa], **T** = 20 [°C] when a solenoid valve is performed in **C** = 2 [dm³/(s·bar)] and **b** = 0.3.

According to formula 1, the maximum flow rate = $600 \times 2 \times (0.4 + 0.1) \times \sqrt{\frac{293}{273 + 20}} = 600$ [L/min (ANR)]

$$\text{Pressure ratio} = \frac{0.3 + 0.1}{0.4 + 0.1} = 0.8$$

Based on Graph (1), it is going to be 0.7 if it is read by the pressure ratio as 0.8 and the flow ratio to be **b** = 0.3.
 Hence, flow rate = Max. flow x flow ratio = 600 x 0.7 = 420 [L/min (ANR)]

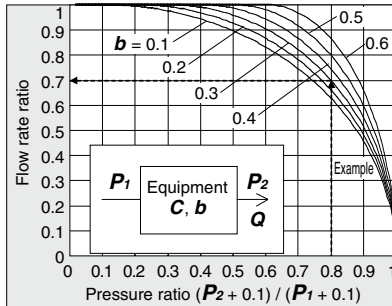

Graph (1) Flow rate characteristics

(4) Test method

Attach a test equipment with the test circuit shown in Fig. (1) while maintaining the upstream pressure to a certain level which does not go below 0.3 MPa. Next, measure the maximum flow to be saturated in the first place, then measure this flow rate at 80%, 60%, 40%, 20% and the upstream and downstream pressure. And then, obtain the sonic conductance **C** from this maximum flow rate. In addition, calculate **b** using each data of others and the subsonic flow formula, and then obtain the critical pressure ratio **b** from that average.

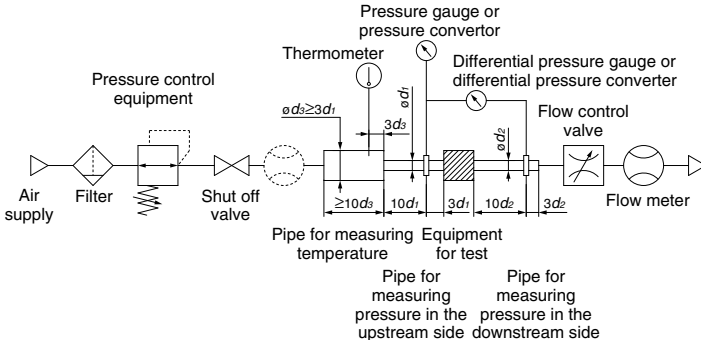

Fig. (1) Test circuit based on ISO 6358: 1989, JIS B 8390: 2000

2.2 Effective area S

(1) Conformed standard

JIS B 8390: 2000: Pneumatic fluid power—Components using compressible fluids—Determination of flow rate characteristics

Equipment standards: JIS B 8373: Solenoid valve for pneumatics

JIS B 8379: Silencer for pneumatics

JIS B 8381-1: Fittings for pneumatics—Part 1: Push-in fittings for thermoplastic resin tubing

JIS B 8381-2: Fittings for pneumatics—Part 2: Compression fittings for thermoplastic resin tubing

(2) Definition of flow rate characteristics

Effective area **S**: The cross-sectional area having an ideal throttle without friction deduced from the calculation of the pressure changes inside an air tank or without reduced flow when discharging the compressed air in a choked flow, from an equipment attached to the air tank. This is the same concept representing the “easy to run through” as sonic conductance **C**.

(3) Formula for flow rate

When

$$\frac{P_2 + 0.1}{P_1 + 0.1} \leq 0.5, \text{ choked flow}$$

$$Q = 120 \times S (P_1 + 0.1) \sqrt{\frac{293}{273 + T}} \dots\dots\dots(3)$$

When

$$\frac{P_2 + 0.1}{P_1 + 0.1} > 0.5, \text{ subsonic flow}$$

$$Q = 240 \times S \sqrt{(P_2 + 0.1) (P_1 - P_2)} \sqrt{\frac{293}{273 + T}} \dots\dots\dots(4)$$

Conversion with sonic conductance **C**:

$$S = 5.0 \times C \dots\dots\dots(5)$$

Q : Air flow rate[L/min(ANR)]

S : Effective area [mm²]

P₁ : Upstream pressure [MPa]

P₂ : Downstream pressure [MPa]

T : Temperature [°C]

Note) Formula for subsonic flow (4) is only applicable when the critical pressure ratio **b** is the unknown equipment. In the formula (2) by the sonic conductance **C**, it is the same formula as when **b** = 0.5.

(4) Test method

Attach a test equipment with the test circuit shown in Fig. (2) in order to discharge air into the atmosphere until the pressure inside the air tank goes down to 0.25 MPa (0.2 MPa) from an air tank filled with the compressed air at a certain pressure level (0.5 MPa) which does not go below 0.6 MPa. At this time, measure the discharging time and the residual pressure inside the air tank which had been left until it turned to be the normal values to determine the effective area **S**, using the following formula. The volume of an air tank should be selected within the specified range by corresponding to the effective area of an equipment for test. In the case of JIS B 8379, the pressure values are in parentheses and the coefficient of the formula is 12.9.

$$S = 12.1 \frac{V}{t} \log_{10} \left(\frac{P_s + 0.1}{P + 0.1} \right) \sqrt{\frac{293}{T}} \dots\dots\dots(6)$$

S : Effective area [mm²]

V : Air tank capacity [L]

t : Discharging time [s]

P_s: Pressure inside air tank

before discharging [MPa]

P : Residual pressure inside air tank

after discharging [MPa]

T : Temperature inside air tank

before discharging [K]

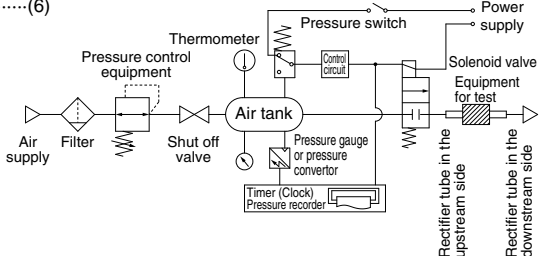

Fig. (2) Test circuit based on JIS B 8390: 2000

VX2
VXK
VXD
VXZ
VXS
VXB
VXE
VXP
VXR
VXH
VXF
VX3
VXA

2.3 Flow coefficient Cv factor

The United States Standard ANSI/(NFPA)T3.21.3: R1-2008R: Pneumatic fluid power—Flow rating test procedure and reporting method for fixed orifice components

This standard defines the Cv factor of the flow coefficient by the following formula that is based on the test conducted by the test circuit analogous to ISO 6358.

$$Cv = \frac{Q}{114.5 \sqrt{\frac{\Delta P (P_2 + P_a)}{T_1}}} \dots\dots\dots(7)$$

ΔP : Pressure drop between the static pressure tapping ports [bar]

P_1 : Pressure of the upstream tapping port [bar gauge]

P_2 : Pressure of the downstream tapping port [bar gauge]: $P_2 = P_1 - \Delta P$

Q : Flow rate [L/s standard condition]

P_a : Atmospheric pressure [bar absolute]

T_1 : Upstream absolute temperature [K]

Test conditions are $P_1 + P_a = 6.5 \pm 0.2$ bar absolute, $T_1 = 297 \pm 5K$, $0.07 \text{ bar} \leq \Delta P \leq 0.14$ bar.

This is the same concept as effective area A which ISO 6358 stipulates as being applicable only when the pressure drop is smaller than the upstream pressure and the compression of air does not become a problem.

3. Process fluid control equipment

(1) Conformed standard

IEC60534-1: 2005: Industrial-process control valves. Part 1: control valve terminology and general considerations

IEC60534-2-3: 1997: Industrial-process control valves. Part 2: Flow capacity, Section Three- Test procedures

JIS B 2005-1: 2012: Industrial-process control valves – Part 1: Control valve terminology and general considerations

JIS B 2005-2-3: 2004: Industrial-process control valves – Part 2: Flow capacity – Section 3: Test procedures

Equipment standards: JIS B 8471: Solenoid valve for water

JIS B 8472: Solenoid valve for steam

JIS B 8473: Solenoid valve for fuel oil

(2) Definition of flow rate characteristics

Kv factor: Value of the clean water flow rate represented by m³/h that runs through the valve (equipment for test) at 5 to 40°C, when the pressure difference is 1 x 10⁵ Pa (1 bar). It is calculated using the following formula:

$$Kv = Q \sqrt{\frac{1 \times 10^5}{\Delta P} \cdot \frac{\rho}{1000}} \dots\dots\dots(8)$$

Kv: Flow coefficient [m³/h]

Q : Flow rate [m³/h]

ΔP: Pressure difference [Pa]

ρ : Density of fluid [kg/m³]

(3) Formula of flow rate

It is described by the practical units. Also, the flow rate characteristics are shown in Graph (2).

In the case of liquid:

$$Q = 53Kv \sqrt{\frac{\Delta P}{G}} \dots\dots\dots(9)$$

Q : Flow rate [L/min]

Kv: Flow coefficient [m³/h]

ΔP: Pressure difference [MPa]

G : Relative density [water = 1]

In the case of saturated aqueous vapor:

$$Q = 232Kv \sqrt{\Delta P(P_2 + 0.1)} \dots\dots\dots(10)$$

Q : Flow rate [kg/h]

Kv: Flow coefficient [m³/h]

ΔP: Pressure difference [MPa]

P₁ : Upstream pressure [MPa]: $\Delta P = P_1 - P_2$

P₂ : Downstream pressure [MPa]

Conversion of flow coefficient:

$$Kv = 0.865 Cv \dots\dots\dots(11)$$

Here,

Cv factor: Value of the clean water flow rate represented by US gal/min that runs through the valve at 40 to 100°F, when the pressure difference is 1 lbf/in² (psi)

Value is different from **Kv** and **Cv** factors for pneumatic purpose due to different test method.

(4) Test method

Connect the equipment for the test to the test circuit shown in Fig. (3), and run water at 5 to 40°C. Then, measure the flow rate with a pressure difference where vaporization does not occur in a turbulent flow (pressure difference of 0.035 MPa to 0.075 MPa when the inlet pressure is within 0.15 MPa to 0.6 MPa). However, as the turbulent flow is definitely caused, the pressure difference needs to be set with a large enough difference so that the Reynolds number does not fall below 1 x 10⁵, and the inlet pressure needs to be set slightly higher to prevent vaporization of the liquid. Substitute the measurement results in formula (8) to calculate **Kv**.

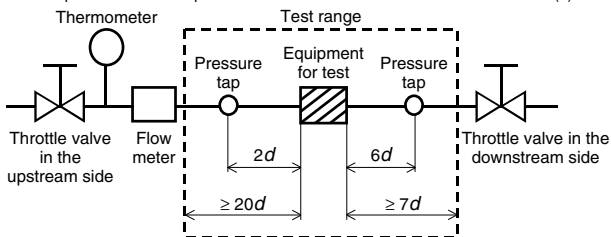
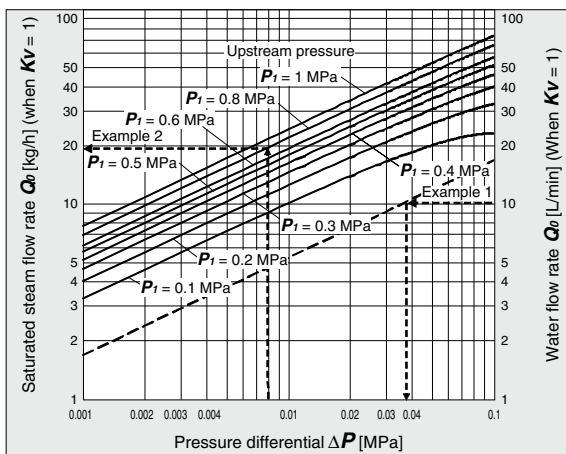

Fig. (3) Test circuit based on IEC60534-2-3, JIS B 2005-2-3



Graph (2) Flow rate characteristics

Example 1)

Obtain the pressure difference when water [15 L/min] runs through the solenoid valve with a **Kv** = 1.5 m³/h. As the flow rate when **Kv** = 1 is calculated as the formula: $Q_0 = 15 \times 1/1.5 = 10$ [L/min], read off ΔP when Q_0 is 10 [L/min] in Graph (2). The reading is 0.036 [MPa].

Example 2)

Obtain the saturated steam flow rate when $P_t = 0.8$ [MPa] and $\Delta P = 0.008$ [MPa] with a solenoid valve with a **Kv** = 0.05 [m³/h]. Read off Q_0 when P_t is 0.8 and ΔP is 0.008 in Graph (2), the reading is 20 kg/h. Therefore, the flow rate is calculated as the formula: $Q = 0.05/1 \times 20 = 1$ [kg/h].

- VX2
- VXK**
- VXD
- VXZ
- VXS
- VXB
- VXE
- VXP
- VXR
- VXH
- VXF
- VX3
- VXA

VXK21/22/23 Series

Flow Rate Characteristics

(Note) Use this graph as a guide. In the case of obtaining an accurate flow rate, refer to pages 99 to 103.

Air

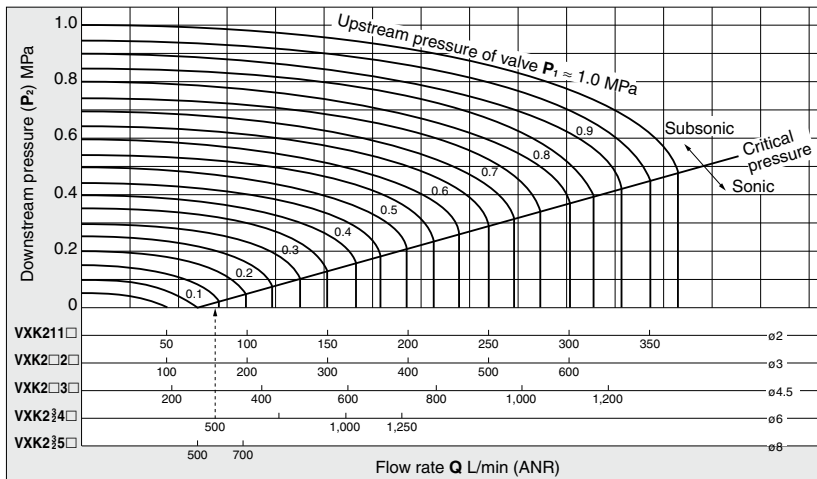

How to read the graph

The sonic range pressure to generate a flow rate of 500 L/min (ANR) is

$P_1 = 0.14$ MPa for a ø6 orifice (VXK2□4□) and

$P_1 = 0.3$ MPa for a ø4.5 orifice (VXK2□3□).

Saturated Steam

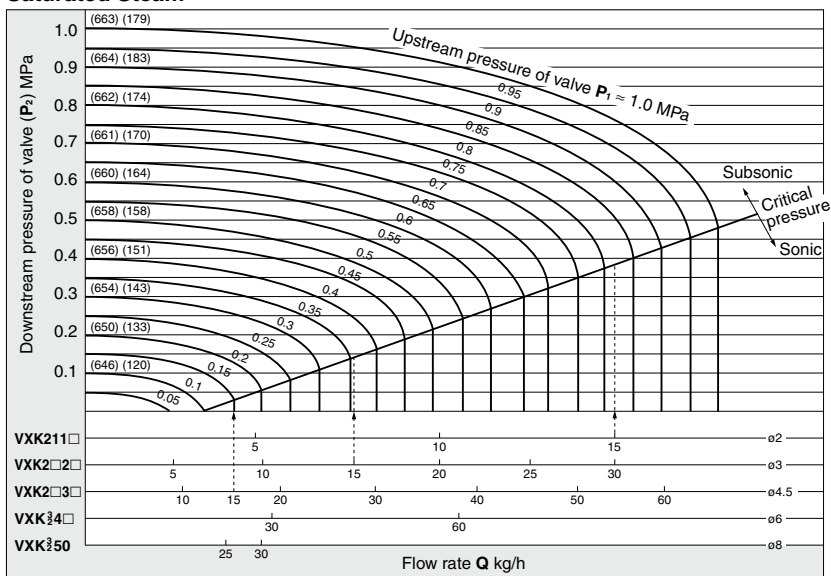

() : Saturated steam holding heat (kcal/kg) () : Saturation temperature (°C)

How to read the graph

The sonic range pressure to generate a flow rate of 15 kg/h is

$P_1 = 0.15$ MPa for ø4.5 orifice (VXK2□3□S), $P_1 = 0.37$ MPa for ø3 orifice (VXK2□2□S), and

$P_1 = 0.82$ MPa for ø2 orifice (VXK211□S). The holding heat slightly differs depending on the pressure P_1 , but at 15 kg/h it is approx. 9700 kcal/h.

Water

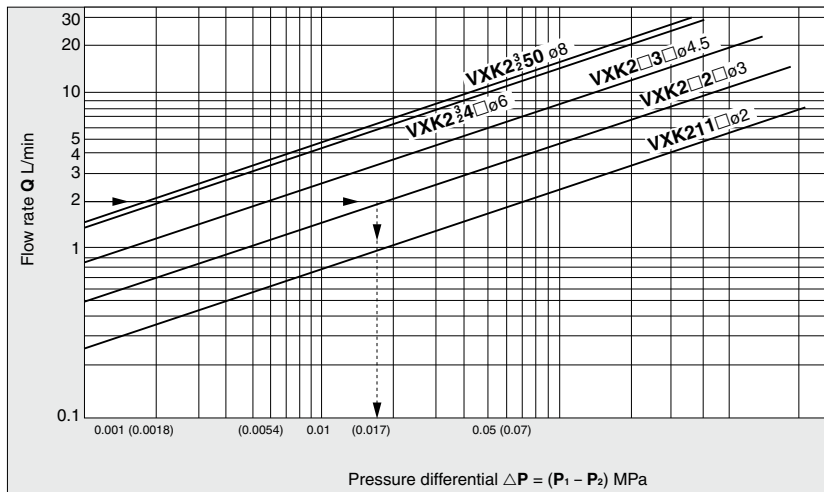

How to read the graph

When a water flow of 2 L/min is generated, $\Delta P = 0.017$ MPa for a valve with $\phi 3$ orifice (VXK212 \square , 222 \square , 232 \square).

- VX2
- VXK**
- VXD
- VXZ
- VXS
- VXB
- VXE
- VXP
- VXR
- VXH
- VXF
- VX3
- VXA



VXK21/22/23 Series Specific Product Precautions 1

Be sure to read this before handling the products.

Refer to back page 50 for Safety Instructions and pages 17 to 19 for 2 Port Solenoid Valve for Fluid Control Precautions.

Design

Warning

- 1. Cannot be used as an emergency shutoff valve etc.**
The valves presented in this catalog are not designed for safety applications such as an emergency shutoff valve. If the valves are used in this type of system, other reliable safety assurance measures should also be adopted.
- 2. Extended periods of continuous energization**
The solenoid coil will generate heat when continuously energized. Avoid using in a tightly shut container. Install it in a well ventilated area. Furthermore, do not touch it while it is being energized or right after it is energized.
- 3. Liquid rings**
In cases with a flowing liquid, provide a bypass valve in the system to prevent the liquid from entering the liquid seal circuit.
- 4. Actuator drive**
When an actuator, such as a cylinder, is to be driven using a valve, take appropriate measures to prevent potential danger caused by actuator operation.
- 5. Pressure (including vacuum) holding**
It is not usable for an application such as holding the pressure (including vacuum) inside of a pressure vessel because air leakage is entailed in a valve.
- 6. When the conduit type is used as equivalent to an IP65 enclosure, install a wiring conduit etc.**
- 7. When an impact, such as water hammer etc., caused by the rapid pressure fluctuation is applied, the solenoid valve may be damaged. Give an attention to it.**

Selection

Warning

- 1. Fluid**
 - 1) Type of fluid**
Before using a fluid, check whether it is compatible with the materials of each model by referring to the fluids listed in this catalog. Use a fluid with a kinematic viscosity of 50 mm²/s or less. If there is something you do not know, please contact SMC.
 - 2) Flammable oil, Gas**
Do not use the product with combustion-supporting or flammable fluids.
 - 3) Corrosive gas**
Cannot be used since it will lead to cracks by stress corrosion or result in other incidents.
 - 4) Use an oil-free specification when any oily particle must not enter the passage.**
 - 5) Applicable fluid on the list may not be used depending on the operating condition. Give adequate confirmation, and then determine a model, just because the compatibility list shows the general case.**

Selection

Warning

2. Fluid quality

<Air>

1) Use clean air.

Do not use compressed air that contains chemicals, synthetic oils including organic solvents, salt or corrosive gases, etc., as it can cause damage or malfunction.

2) Install an aftercooler or air dryer, etc.

Compressed air that contains excessive drainage may cause malfunction of valves and other pneumatic equipment. To prevent this, install an aftercooler or air dryer, etc.

3) If excessive carbon powder is generated, eliminate it by installing mist separators at the upstream side of valves.

If excessive carbon powder is generated by the compressor, it may adhere to the inside of the valves and cause a malfunction.

Refer to Best Pneumatics No.5 for further details on compressed air quality.

<Vacuum>

Please be aware that there is a range of pressure that can be used.

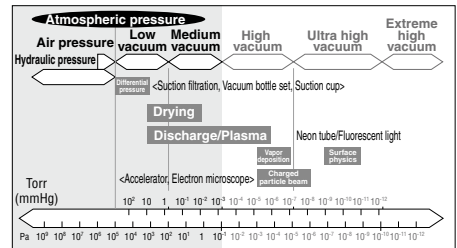

Vacuum piping direction: if the system uses a vacuum pump, we ask that you install the vacuum pump on the secondary side.

Please replace the valve after operating the device approximately 300,000 times.



VXK21/22/23 Series

Specific Product Precautions 2

Be sure to read this before handling the products.

Refer to back page 50 for Safety Instructions and pages 17 to 19 for 2 Port Solenoid Valve for Fluid Control Precautions.

Selection

⚠ Warning

<Water>

The supply water includes materials that generate hard sediment or sludge such as calcium and magnesium. Since such scale and sludge can cause the valve to malfunction, install water softening equipment to remove these substances.

Tap water pressure:

The water pressure for tap water is normally 0.4 MPa or less. However, in places like a high-rise building, the pressure may be 1.0 MPa. When selecting tap water, be careful of the maximum operating pressure differential.

<Oil>

Generally, FKM is used as seal material, as it is resistant to oil. The resistance of the seal material may deteriorate depending on the type of oil, manufacturer or additives. Check the resistance before using. The kinematic viscosity must not exceed 50 mm²/s.

<Steam>

The supply water to a boiler includes materials that create a hard sediment or sludge such as calcium and magnesium. Sediment and sludge from steam can cause the valve to not operate properly. Install a water softening device, which removes these materials. Do not use operation steam which contains chemicals, synthetic oils containing organic solvents, salts or corrosive gases, etc., as these can cause damage or deterioration.

3. Ambient environment

Use within the operable ambient temperature range. Check the compatibility between the product's composition materials and the ambient atmosphere. Be certain that the fluid used does not touch the external surface of the product.

4. Countermeasures against static electricity

Take measures to prevent static electricity since some fluids can cause static electricity.

5. Low temperature operation

- 1) The valve can be used in an ambient temperature of between -20°C. However, take measures to prevent freezing or solidification of impurities, etc.
- 2) When using valves for water application in cold climates, take appropriate countermeasures to prevent the water from freezing in tubing after cutting the water supply from the pump, by draining the water etc. When warming by a heater etc., be careful not to expose the coil portion to a heater. Installation of a dryer, heat retaining of the body is recommended to prevent a freezing condition in which the dew point temperature is high and the ambient temperature is low, and the high flow runs.

Selection

⚠ Caution

1. Leakage voltage

When operating the solenoid valve with the controller, take appropriate measures so that the leakage current does not exceed the allowable leakage voltage of the product. Particularly when using a resistor in parallel with a switching element and using a C-R element (surge voltage suppressor) to protect the switching element, take note that leakage current will flow through the resistor, C-R element, etc., creating a possible danger that the valve may not turn off.

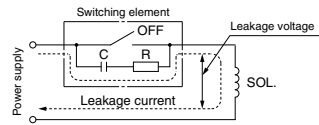

AC coil: 5% or less of rated voltage
DC coil: 2% or less of rated voltage

2. Selecting model

Material depends on fluid. Select optimal models for the fluid.

3. When the fluid is oil.

The kinematic viscosity must not exceed 50 mm²/s.

Mounting

⚠ Warning

1. If air leakage increases or equipment does not operate properly, stop operation.

After mounting is completed, confirm that it has been done correctly by performing a suitable function test.

2. Do not apply external force to the coil section.

When tightening is performed, apply a wrench or other tool to the outside of the piping connection parts.

3. Mount a valve with its coil position upward, not downward.

When mounting a valve with its coil positioned downward, foreign objects in the fluid will adhere to the iron core leading to a malfunction. Especially for strict leakage control, such as with vacuum applications and non-leak specifications, the coil must be positioned upward.

4. Do not warm the coil assembly with a heat insulator etc.

Use tape, heaters, etc., for freeze prevention on the piping and body only. They can cause the coil to burn out.

5. Secure with the mounting holes firmly, except in the case of steel piping and copper fittings.

6. Avoid sources of vibration, or adjust the arm from the body to the minimum length so that resonance will not occur.

7. Painting and coating

Warnings or specifications printed or labeled on the product should not be erased, removed or covered up.

VX2

VXK

VXD

VXZ

VXS

VXB

VXE

VXP

VXR

VXH

VXF

VX3

VXA



VXK21/22/23 Series Specific Product Precautions 3

Be sure to read this before handling the products.

Refer to back page 50 for Safety Instructions and pages 17 to 19 for 2 Port Solenoid Valve for Fluid Control Precautions.

Replacement of Solenoid Coil

N.C.

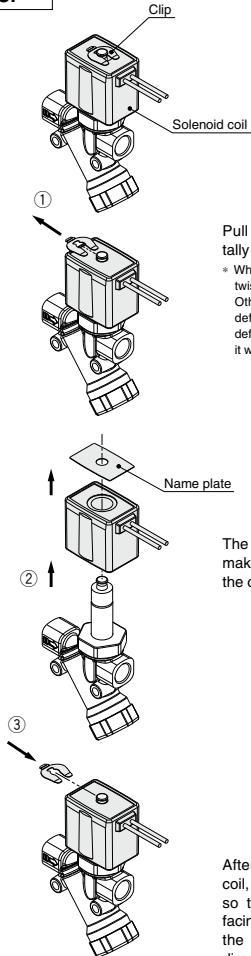

Pull out the clip horizontally in direction ①.

* When doing this, do not apply twisting or torsion to the clip. Otherwise, the clip may be deformed. If the clip is deformed by mistake, replace it with a new one.

The removal of the clip will make it possible to remove the coil in direction ②.

After replacement of the coil, attach the name plate so that its printed side is facing upwards, and press the clip horizontally in direction ③.

N.O.

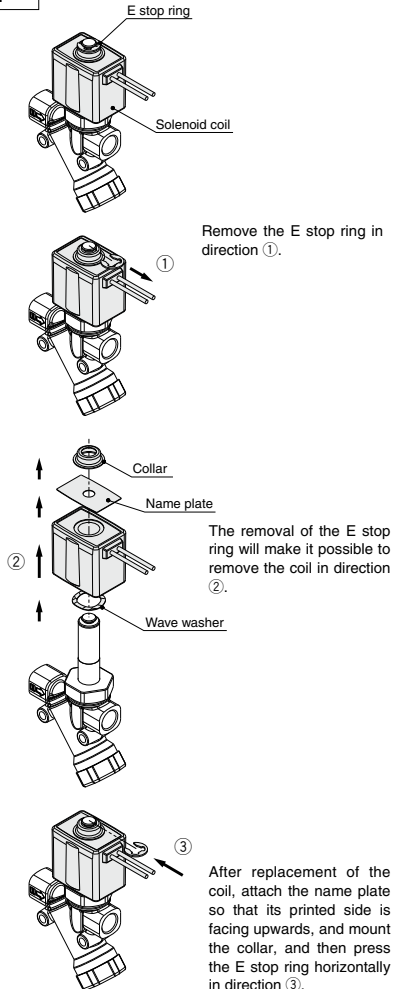

Remove the E stop ring in direction ①.

The removal of the E stop ring will make it possible to remove the coil in direction ②.

After replacement of the coil, attach the name plate so that its printed side is facing upwards, and mount the collar, and then press the E stop ring horizontally in direction ③.

Warning

1. When replacing the solenoid coil, turn off the power supply.
2. Be careful for possible high temperature of the solenoid coil due to the fluid temperature and operating conditions.
3. Check the type of the solenoid coil (size, rated voltage, voltage specification, insulation specification).

* Replacement of solenoid coil

- Cannot be changed between DC and AC.
- Can be changed between DC and AC (built-in full-wave rectifier type).
- Can be changed from DC to DC.
- Can be changed from AC to AC.



VXK21/22/23 Series

Specific Product Precautions 4

Be sure to read this before handling the products.

Refer to back page 50 for Safety Instructions and pages 17 to 19 for 2 Port Solenoid Valve for Fluid Control Precautions.

Replacement of Strainer

⚠ Warning

- The valve will reach high temperatures from high temperature fluids such as steam. Confirm that the valve has cooled sufficiently before performing works. If touched inadvertently, there is a danger of being burned.
- Shut off the fluid supply and release the fluid pressure in the system.
- Shut off the power supply.
 - Turn and remove the plug (width across flats of 27 mm).
 - Remove the strainer, and clean or replace it.
 - Mount the O-ring on the plug and insert the strainer to the end of the plug.
 - Screw the plug into the body. (Recommended tightening torque: 23 to 27 N·m)

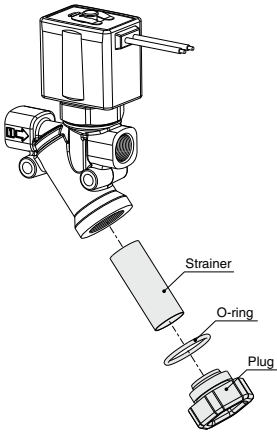

Piping

⚠ Warning

- During use, deterioration of the tube or damage to the fittings could cause tubes to come loose from their fittings and thrash about. To prevent uncontrolled tube movement, install protective covers or fasten tubes securely in place.
- For piping to the tube, fix the product securely using the mounting holes so that the product is not in the air.

⚠ Caution

1. Preparation before piping

Before piping is connected, it should be thoroughly blown out with air (flushing) or washed to remove chips, cutting oil and other debris from inside the pipe. Avoid pulling, compressing, or bending the valve body when piping.

Piping

⚠ Caution

- Avoid connecting ground lines to piping, as this may cause electric corrosion of the system.
- Always tighten threads with the proper tightening torque.

When using steel piping, tighten with the proper tightening torque shown below.

Lower tightening torque will lead into fluid leakage.

Tightening Torque for Piping

Thread size	Proper tightening torque (N·m)
Rc1/8	7 to 9
Rc1/4	12 to 14
Rc3/8	22 to 24

4. Connection of piping to products

When connecting piping to a product, avoid mistakes regarding the supply port etc.

5. Winding of sealant tape

When connecting pipes, fittings, etc., be sure that chips from the pipe threads and sealing material do not enter the valve.

Furthermore, when sealant tape is used, leave 1.5 to 2 thread ridges exposed at the end of the threads.

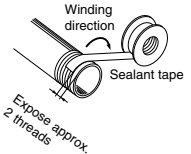

- In applications such as vacuum and non-leak specifications, use caution specifically against the contamination of foreign objects or airtightness of the fittings.

Wiring

⚠ Caution

- As a rule, use electrical wire with a cross sectional area of 0.5 to 1.25 mm² for wiring. Furthermore, do not allow excessive force to be applied to the lines.
- Use electrical circuits which do not generate chattering in their contacts.
- Use voltage which is within $\pm 10\%$ of the rated voltage. In cases with a DC power supply where importance is placed on responsiveness, stay within $\pm 5\%$ of the rated value. The voltage drop is the value in the lead wire section connecting the coil.
- When a surge from the solenoid affects the electrical circuitry, install a surge voltage suppressor etc., in parallel with the solenoid. Or, adopt an option that comes with the surge voltage protection circuit. (However, a surge voltage occurs even if the surge voltage protection circuit is used. For details, please consult with SMC.)

VX2

VXK

VXD

VXZ

VXS

VXB

VXE

VXP

VXR

VXH

VXF

VX3

VXA



VXK21/22/23 Series

Specific Product Precautions 5

Be sure to read this before handling the products.

Refer to back page 50 for Safety Instructions and pages 17 to 19 for 2 Port Solenoid Valve for Fluid Control Precautions.

Operating Environment

Warning

1. Do not use in an atmosphere having corrosive gases, chemicals, sea water, water, water steam, or where there is direct contact with any of these.
2. Do not use in explosive atmospheres.
3. Do not use in locations subject to vibration or impact.
4. Do not use in locations where radiated heat will be received from nearby heat sources.
5. Employ suitable protective measures in locations where there is contact with water droplets, oil or welding spatter, etc.

Maintenance

Warning

1. Removing the product

The valve will reach a high temperature when used with high temperature fluids. Confirm that the valve temperature has dropped sufficiently before performing work. If touched inadvertently, there is a danger of being burned.

- 1) Shut off the fluid supply and release the fluid pressure in the system.
- 2) Shut off the power supply.
- 3) Dismount the product.

2. Low frequency operation

Switch valves at least once every 30 days to prevent malfunction. Also, in order to use it under the optimum state, conduct a regular inspection once a half year.

Caution

1. Strainers

- 1) Be careful regarding clogging of strainers.
- 2) Clean strainers when the pressure drop reaches 0.1 MPa.

2. Lubrication

When using after lubricating, never forget to lubricate continuously.

3. Storage

In case of long term storage after use, thoroughly remove all moisture to prevent rust and deterioration of rubber materials etc.

4. Exhaust the drainage from an air filter periodically.

Operating Precautions

Warning

1. If there is a possibility of reverse pressure being applied to the valve, take countermeasures such as mounting a check valve on the downstream side of the valve.
2. When problems are caused by a water hammer, install water hammer relief equipment (accumulator etc.), or use an SMC water hammer relief valve (VXR series). For details, please consult with SMC.

Electrical Connections

Caution

■ Grommet

Class H coil: AWG18 Insulator O.D. 2.2 mm

Class B coil: AWG20 Insulator O.D. 2.5 mm

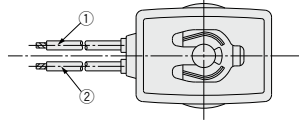

Rated voltage	Lead wire color	
	①	②
DC	Black	Red
100 VAC	Blue	Blue
200 VAC	Red	Red
Other AC	Gray	Gray

* There is no polarity.

■ DIN terminal

Since internal connections are shown below for the DIN terminal, make connections to the power supply accordingly.

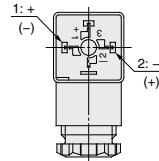

Terminal no.	1	2
DIN terminal	+ (-)	- (+)

* There is no polarity.

- Use compatible heavy duty cords with cable O.D. ø6 to ø12 mm.
- Use the tightening torques below for each section.

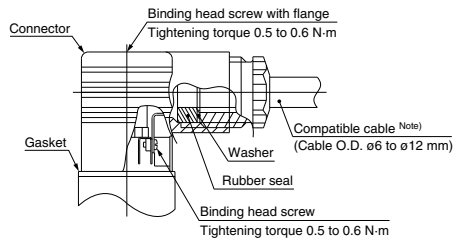

Note) For an outside cable O.D. ø9 to ø12 mm, remove the internal parts of the rubber seal before using.



VXK21/22/23 Series Specific Product Precautions 6

Be sure to read this before handling the products.
Refer to back page 50 for Safety Instructions and pages 17 to 19 for 2 Port Solenoid Valve for Fluid Control Precautions.

Electrical Connections

⚠ Caution

Conduit terminal

In the case of the conduit terminal, make connections according to the marks shown below.

- Use the tightening torques below for each section.
- Properly seal the terminal connection (G1/2) with the special wiring conduit, etc.

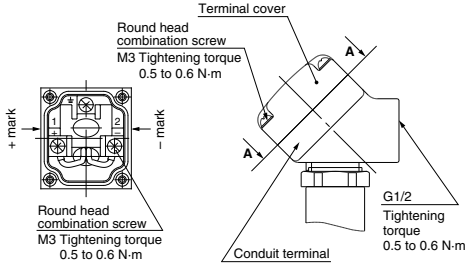

View A-A

(Internal connection diagram)

Conduit

When used as an IP65 equivalent, use seal (part no. VCW20-15-6) to install the wiring conduit. Also, use the tightening torque below for the conduit.

Class H coil: AWG18 Insulator O.D. 2.2 mm
Class B coil: AWG20 Insulator O.D. 2.5 mm

Lead wire

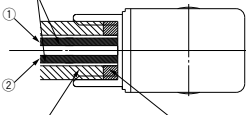

Wiring conduit (Bore size G1/2)

Seal (VCW20-15-6)
Tightening torque 0.5 to 0.6 N·m

Rated voltage	Lead wire color	
	①	②
DC	Black	Red
100 VAC	Blue	Blue
200 VAC	Red	Red
Other AC	Gray	Gray

* There is no polarity for DC.

Description	Part no.
Seal	VCW20-15-6

Note) Please order separately.

Electrical Circuits

⚠ Caution

[DC circuit]

Grommet, Conduit, Conduit terminal, DIN type

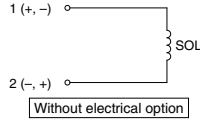

Grommet, Conduit terminal, DIN type

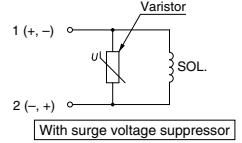

Conduit terminal, DIN type

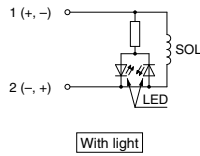

Conduit terminal, DIN type

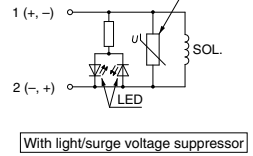

[AC, Class B (Built-in full wave rectifier type) Circuit]

* For AC/Class B, the standard product is equipped with surge voltage suppressor.

Grommet, Conduit, Conduit terminal, DIN type

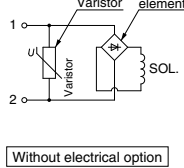

Conduit terminal, DIN type

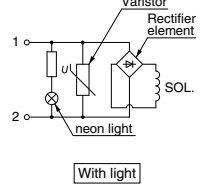

[AC, Class B/H Circuit]

Grommet, Conduit, Conduit terminal

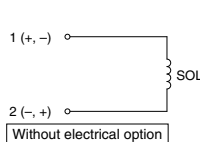

Grommet, Conduit terminal

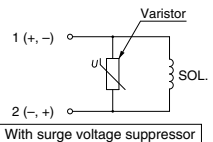

Conduit terminal

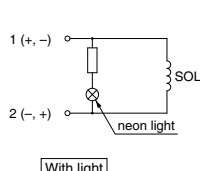

Conduit terminal

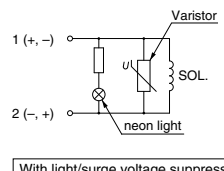

VX2

VXK

VXD

VXZ

VXS

VXB

VXE

VXP

VXR

VXH

VXF

VX3

VXA